

# DL250

Operation and Maintenance Manual

K1023774E

Serial Number 5001 and Up

November 2006

*DOOSAN* reserves the right to improve our products in a continuing process to provide the best possible product to the market place. These improvements can be implemented at any time with no obligation to change materials on previously sold products. It is recommended that consumers periodically contact their distributors for recent documentation on purchased equipment.

This documentation may include attachments and optional equipment that is not available in your machine's package. Please call your distributor for additional items that you may require.

Illustrations used throughout this manual are used only as a representation of the actual piece of equipment, and may vary from the actual item.



# Table of Contents

<b>Safety .....</b>	<b>1-1</b>
To the Operator of a Wheel Loader .....	1-1
General Safety Essentials .....	1-4
Location of Safety Labels .....	1-4
Unauthorized Modifications.....	1-13
General Hazard Information .....	1-13
Before Starting Engine .....	1-22
Machine Operation.....	1-26
Maintenance .....	1-34
Battery.....	1-45
Towing .....	1-47
Shipping and Transportation .....	1-48
<b>Operating Controls .....</b>	<b>2-1</b>
Component Locations .....	2-2
Operator's Area.....	2-4
Steering Console and Pedals.....	2-5
Front Instrument Panel.....	2-14
Right Side Switch Panel .....	2-25
Various Cabin Locations .....	2-41
Heater and Air Conditioner Operation .....	2-45
Stereo / CD Player (Optional) .....	2-50
Seat Adjustment.....	2-52
Seat Belt.....	2-54
Door Side Latch.....	2-55
Arm Rest .....	2-56
Fuse Box/Relay/Engine Emergency Stop Switch.....	2-57

<b>Operation.....</b>	<b>3-1</b>
Instrument Panel Control Functions .....	3-1
New Machine Break-in Procedures .....	3-1
Engine Start and Stop .....	3-2
Machine Travel.....	3-11
Machine Shut Down .....	3-14
F/R (Forward/Reverse) Travel Control System (Option).....	3-16
Additional Braking .....	3-17
Boom Raise Kick-out.....	3-18
Bucket Angle Indicator .....	3-18
Boom Lower Kick-out (Option) .....	3-19
Adjustment of Bucket Position Switch .....	3-19
Towing Machine .....	3-20
If Engine Stalls While Traveling.....	3-21
Allowable Water Depth.....	3-22

**Inspection, Maintenance and Adjustment .....4-1**

Basic Preventive Maintenance .....	4-1
Safety When Servicing .....	4-4
Preventive Maintenance.....	4-12
Table of Recommended Lubricants.....	4-14
Axle Oils DL400, DL300, DL250.....	4-16
Fluid Capacities.....	4-19
Lubrication and Service Chart .....	4-20
Maintenance Intervals .....	4-24
10 Hour / Daily Service .....	4-26
50 Hour / Weekly Service .....	4-35
250 Hour / Monthly Service .....	4-41
500 Hour / 3 Month Service .....	4-46
1,000 Hour / 6 Month Service .....	4-53
1,500 Hour / 9 Month Service .....	4-61
2,000 Hour / Yearly Service.....	4-64
12,000 Hour / Six Year Service.....	4-70

Severe Conditions Maintenance .....	4-71
Bolt Torque Chart.....	4-72
Electrical System.....	4-73
Engine Cooling System.....	4-75
Handling of Accumulator .....	4-77
Hydraulic Pressure Checks.....	4-78
Long Term Storage .....	4-83
Parking Brake Adjustment.....	4-84
Tires.....	4-86
<b>Transportation .....</b>	<b>5-1</b>
Loading and Unloading .....	5-1
Summary of Safety Precautions for Lifting.....	5-2
<b>Troubleshooting .....</b>	<b>6-1</b>
Engine.....	6-1
Hydraulic System .....	6-3
Travel System.....	6-5
Steering.....	6-6
Braking.....	6-7
Electrical System.....	6-7
<b>Specification .....</b>	<b>7-1</b>
General Specifications .....	7-1
Working Range and Dimensions.....	7-2
Working Capacities .....	7-4
Approximate Weight of Workload Materials.....	7-4
<b>Index .....</b>	<b>8-1</b>



# Presentation

## PRESENTATION

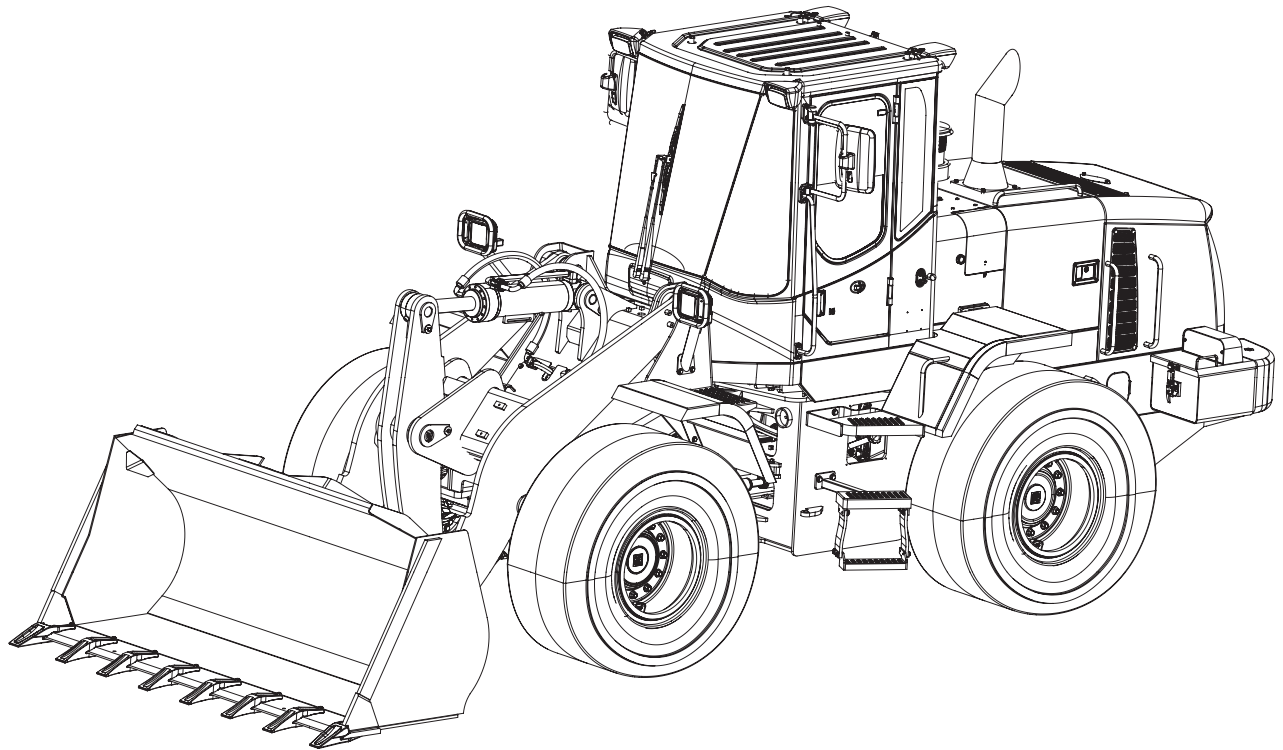

FG006259

Figure 1

## Intended Use

The machine is intended to be used under normal conditions for the applications described in the Operator's Manual. If it is used for other purposes or in potentially dangerous environments, for example explosive atmosphere or areas with dust containing asbestos, etc., special safety regulations must be followed and the machine must be equipped for such use. Contact the manufacturer/dealer for further information.

The machine is designed for a maximum machine weight (includes equipment and attachments) of 14,500 kg (32,077 lb) for DL250. If the maximum weight is exceeded, no warranties on the part of the manufacturer will apply. However, always pay attention to national regulations for traveling on public roads.

## Engine

DL250 has a *DOOSAN* DL06 5.9 liter engine. The engine has intercooling and is fitted with a common rail system. The common rail system is positioned at an angle above the pistons and are controlled via the camshaft and a electronic control module (ECM).

The cylinder head covers all cylinders.

The engine has four valves per cylinder.

The accelerator position is transferred electrically from accelerator pedal.

## Electrical System

The machine has three control units. The Gauge Panel for the instrumentation is integrated with the display unit, warning lights and instruments and provides the operator with information via there. The Control Unit (for the machine) receives signals from sensors on the machine and these are passed to the Gauge Panel. The ECU controls the engine.

## Power Transmission

The transmission is electrohydraulically controlled, where all gears are in constant mesh. The gear ranges are achieved by applying different combinations of clutches. Between the engine and transmission gears there is a hydraulic torque converter, which controls the output torque. The front and rear axles have planetary gears in the wheel hubs and this reduces the strain on the respective drive shafts. The axles differentials use a LSD (Limited Slip Differential) design.

## Brake System

The machine is provided with a dual circuit, all hydraulic, brake system with one circuit for each axle. Each circuit meets the requirements for secondary brake capability.

## Parking Brake

The parking brake is a dry disk brake built into the transmission output shaft. The brake is applied by spring force and is released hydraulically.

## Steering System

The machine uses a load sensing, hydrodynamic steering system. It has a steering arc of 40°.

## Cabin

The cabin has a heating and ventilation system with defrosting for front and rear windows. Air-conditioning is standard. The cabin has two emergency exits, the door and right side window.

## FOPS and ROPS

The cabin is approved as a protective cabin according to FOPS and ROPS standards. FOPS is an abbreviation of Falling Object Protective Structure (roof protection) and ROPS is an abbreviation of Roll Over Protective Structure (roll over protection).

Never carry out any unauthorized alterations to the cabin, e.g. lowering the roof height, drilling, welding on brackets for fire extinguisher, radio aerial or other equipment, without first having discussed the alteration with personnel at the *DOOSAN Infracore* Engineering Department. This department will decide whether the alteration may cause the approval to become void. It is important that all parties concerned are aware of these regulations.

## Hydraulic System

The hydraulic system use a triple vane pump which contains three pumping sections.

The first pumping section supplies oil for the front attachment. The second pumping section supplies oil for the steering cylinders. Surplus oil which is not necessary for the steering function is directed into control valve to join the first pump's oil.

The third pump section is the cooling & brake & pilot pump, used for brake & pilot line and cooling fan motor operation.

## Equipment

The machine can be provided with different types of optional equipment, depending on the requirements of different markets. Examples of such equipment are lever steering, Boom Suspension System (LIS), secondary steering, separate attachment locking, automatic greasing.

## CE MARKING, EMC DIRECTIVE

### CE Marking

**(Declaration of Conformity)**

**(Only applies to machines marketed within the EU/EEA.)**

This machine is CE marked. This means that when delivered the machine meets the applicable "Essential Health and Safety Requirements," which are given in the Machinery Safety Directive, 98/37EC.

Any person carrying out changes that affect the safety of the machine, is also responsible for the same.

As proof that the requirements are met, the machine is supplied with an EU Declaration of Conformity, issued by *DOOSAN CE* for each separate machine. This EU declaration also covers attachments manufactured by *DOOSAN CE*. The documentation is a valuable document, which must be kept safe and retained for at least ten years. The document should always accompany the machine when it is sold.

If the machine is used for other purposes or with other attachments than described in this manual, safety must at all times and in each separate case be maintained. The person carrying out such action is also responsible for the action which, in some cases, may require a new CE marking and the issue of a new EU Declaration of Conformity.

### The EU EMC Directive

The electronic equipment of the machine may in some cases cause interference to other electronic equipment, or suffer from external electromagnetic interference, which may constitute safety risks.

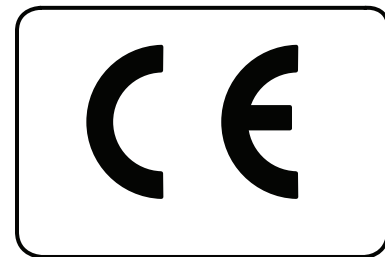

FG001781

Figure 2

The EU EMC directive on "Electromagnetic Compatibility," 89/336/EEC, provides a general description of what demands can be made on the machine out of a safety point of view, where permitted limits have been determined and given according to international standards.

A machine or device which meets the requirements must be CE marked. Our machines have been tested particularly for electromagnetic interference. The CE marking of the machine and the declaration of conformity also cover the EMC directive.

If other electronic equipment is fitted to this machine, the equipment must be CE marked and tested on the machine with regard to electromagnetic interference.

## **COMMUNICATION EQUIPMENT INSTALLATION**

---

### **IMPORTANT**

---

All installation of optional communication equipment must be carried out by trained professionals and in accordance with the *DOOSAN CE* instructions applicable to the machine.

---

### **Protection Against Electromagnetic Interference**

This machine has been tested in accordance with EU directive 89/336/EEC governing electromagnetic interference. It is therefore very important that all nonapproved electronic accessories, such as communication equipment, must be tested before installation and use, since they can cause interference to the electronic systems of the machine.

# PRODUCT PLATES

With the aid of the product plates, shown below, it is possible to identify the machine and its components. The Product Identification Number, PIN, indicates the model designation, engine code and serial number of the machine. The Component Identification Number, CIN, indicates the serial number of the component. Make a note of the identification numbers.

When ordering spare parts, and in all telephone enquiries or correspondence the PIN and CIN must always be quoted.

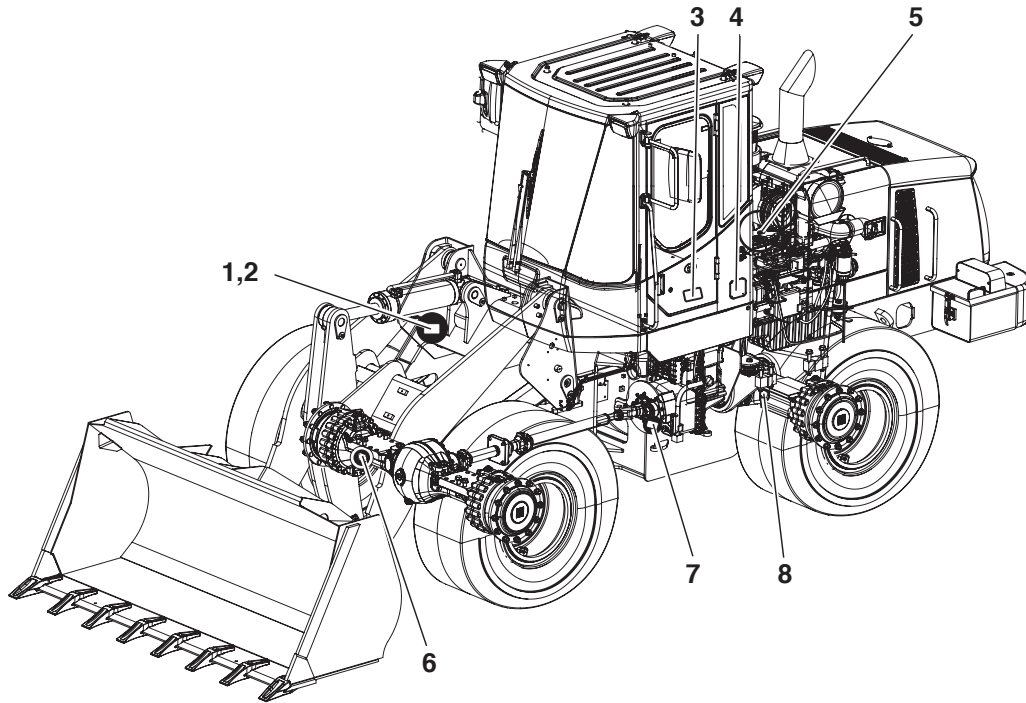

FG006262

**Figure 1**

Reference Number	Description	
1	Primary Marking	The machine PIN (stamped into right side).
2	Product Plate	The manufacturer's name and address, machine PIN.
3	Additional Plate for Product Plate	Machine weight, engine output year of manufacture, year of delivery and position of CE mark (EU/EEA countries only).
4	Cabin	The manufacturer's name and address, product number, machine model designation, max. machine weight, cabin serial number, ROPS/FOPS number and ROPS/FOPS certificate number.
5	Engine	The engine type designation and number.
6	Front Axle	The manufacturer's name and address and front drive axle CIN.
7	Transmission	The manufacturer's name and address and transmission CIN.
8	Rear Axle	The manufacturer's name and address and rear drive axle CIN.

# Safety

## TO THE OPERATOR OF A WHEEL LOADER

---



### **DANGER!**

---

**Improper use of wheel loader could cause serious injury or death. Before operating wheel loader, or performing maintenance, operator or technician must read and understand entire Operation and Maintenance Manual.**

**Any operation, maintenance, traveling or shipping methods that do not follow safety guidelines printed in this Manual could cause serious injury or death.**

---

Please respect the importance of taking responsibility for your own safety, and that of other people who may be affected by your actions.

The safety information on the following pages is organized into the following sections:

1. "General Safety Essentials" on page 1-4
2. "Location of Safety Labels" on page 1-4
3. "Unauthorized Modifications" on page 1-13
4. "General Hazard Information" on page 1-13
5. "Before Starting Engine" on page 1-22
6. "Machine Operation" on page 1-26
7. "Maintenance" on page 1-34
8. "Battery" on page 1-45
9. "Towing" on page 1-47
10. "Shipping and Transportation" on page 1-48



## **SAFETY ALERT SYMBOL**



**Be Prepared – Get to Know All Operating and Safety Instructions.**

**This is the Safety Alert Symbol. Wherever it appears – in this manual or on safety signs on the machine – you must be alert to potential for personal injury or accidents. Always observe safety precautions and follow recommended procedures.**

---

### **Learn Signal Words Used With Safety Alert Symbol**

The words "**CAUTION**," "**WARNING**," and "**DANGER**" used throughout this manual and on decals on the machine indicate degree of risk of hazards or unsafe practices. All three degrees of risk indicate that safety is involved. Observe precautions indicated whenever you see the Safety Alert "Triangle," no matter which signal word appears next to the "Exclamation Point" symbol.

---



#### **CAUTION!**

**This word is used on safety messages and safety labels and indicates potential of a hazardous situation that, if not avoided, could result in minor or moderate injury. It may also be used to alert against a generally unsafe practice.**

---



#### **WARNING!**

**This word is used on safety messages and safety labels and indicates potential of a hazardous situation that, if not avoided, could result in serious injury or death. It may also be used to alert against a highly unsafe practice.**

---



#### **DANGER!**

**This word is used on safety messages and safety labels and indicates an imminent hazard of a situation that, if not avoided, is very likely to cause death or extremely serious injury. It may also be used to alert against equipment that may explode or detonate if handled or treated carelessly.**

---

Safety precautions are described in SAFETY from page 1-4 on.

*DOOSAN* cannot predict every circumstance that might involve a potential hazard in operation and maintenance. Therefore the safety messages in this manual and on the machine may not include all possible safety precautions. If any procedures or actions not specifically recommended or allowed in this manual are used, you must be sure that you and others can do such procedures and actions safely and without damaging the machine. If you are unsure about the safety of some procedures, contact a *DOOSAN* distributor.

# GENERAL SAFETY ESSENTIALS

## Accessory Applications

The wheel loader has been designed primarily for moving earth with a bucket. For use as a grapple or for other object handling, contact *DOOSAN*. Lifting-work applications are permitted in approved lift configuration, to rated capacity only, with no side-loading (unless prohibited by local regulation). Do not use machine for activities for which it was not intended. Do not use bucket for lifting work, unless lift slings are used in approved configuration.

## LOCATION OF SAFETY LABELS

The operator should know and pay attention to the information and warning plates/decals which are positioned on the machine.

There are several specific warning signs on this machine. The exact location of hazards and the description of the hazards are reviewed in this section.

Please become familiarized with all warning signs.

Make sure that all of the warning signs are legible. Clean the warning signs or replace the warning signs if you cannot read the words. Replace the illustrations if the illustrations are not visible. When you clean the warning signs, use a cloth, water and soap. Do not use solvent, gasoline, or other harsh chemicals to clean the safety signs. Solvents, gasoline, or other harsh chemicals could loosen the adhesive that secures the warning sign. Loose adhesive will allow the warning sign to fall off.

Replace any safety sign that is damaged, or missing. If a safety sign is attached to a part that is replaced, install a safety sign on the replacement part.

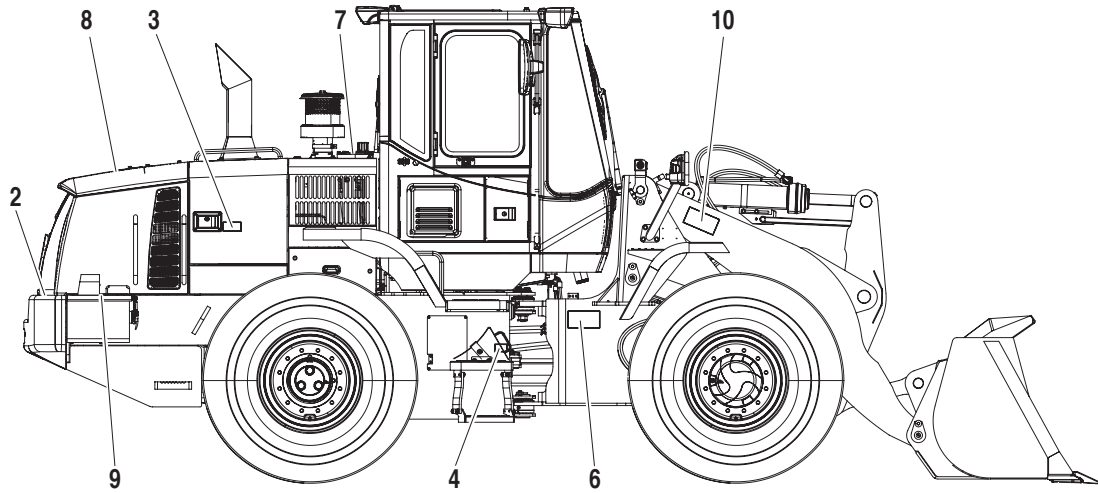
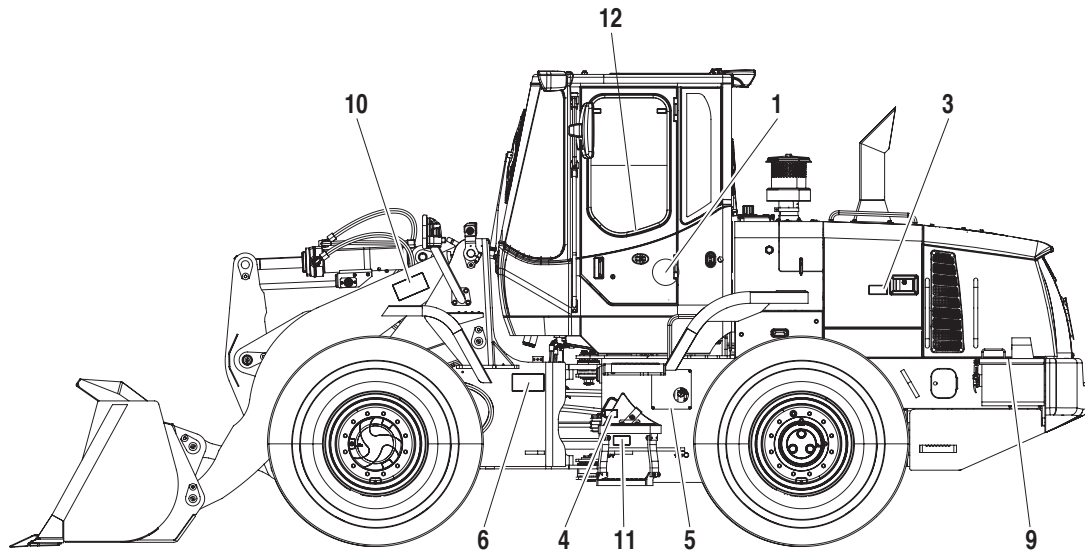

FG008049

Figure 1

## 1. Warnings for Operation, Inspection and Maintenance (4190-2545A, 190-00092)



### CAUTION!

- Read manual and labels before operation and maintenance. Follow instructions and warnings in manual and on labels on machine.
- Sound horn to alert people nearby before operating, and make sure all persons are clear of area.
- Always make sure when leaving operator's seat to:
  - Lower bucket or other working tools to ground.
  - "LOCK" transmission selector in "NEUTRAL."
  - Set park brake.
  - Turn starter switch "OFF." Remove key from switch.
- If hydraulic components and units are **ABNORMAL**, consult nearest **DOOSAN** dealer or authorized service shop. Do not attempt to make an overhaul.

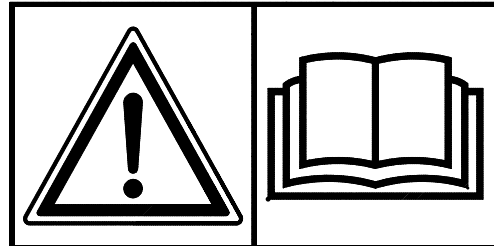

ACO1360L

## 2. Warnings for Cooling Fan (2190-3315, 190-00557)



### WARNING!

Keep your hands away from the fan during operation. Entanglement in the fan can cause serious injury.

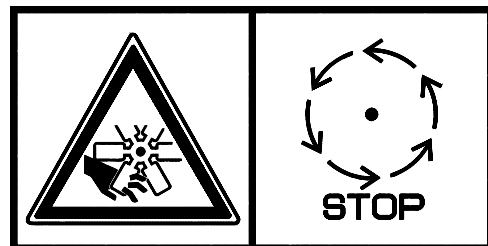

AMO0390L

### 3. Warnings When Opening Engine Hood (190-00095)

#### **WARNING!**

Before opening hood, shut down engine.

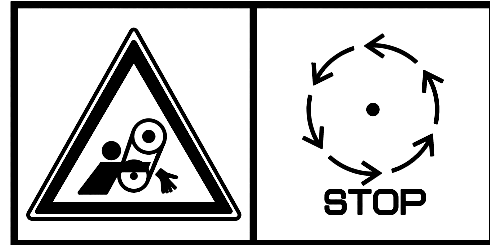

ACO1420L

### 4. Warnings for Using Wheel Block (4190-2547A, 190-00207)

#### **WARNING!**

Block wheels to prevent machine movement before disengaging park brake.

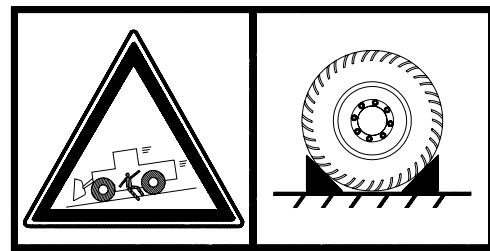

AMO0400L

## 5. Warnings for Handling Accumulator (190-00703, 190-00099)



### WARNING!

#### Explosion hazard:

- Keep away from flame.
- Do not weld or drill.

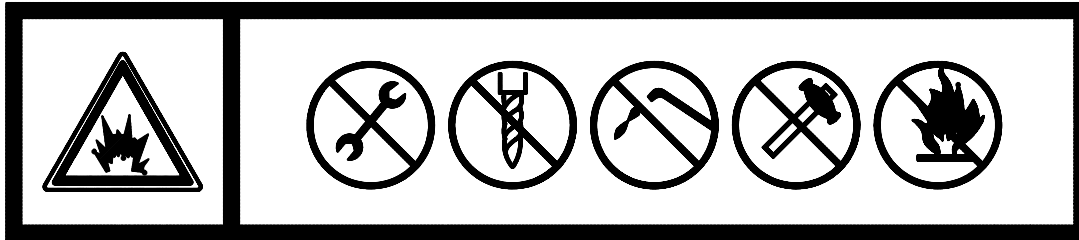

ACO1480L

## Accumulator

Wheel loader pilot control system is equipped with an accumulator. Accumulator will store a pressure charge that may enable hydraulic controls to be activated for a brief period of time after engine has been shut down. Activation of any controls may enable selected function to operate under force of gravity.



### CAUTION!

**Any raised attachment will lower to ground if accumulator holds a charge.**

When shutting machine down, lower front attachment to ground. After engine has been shut down, turn key to "ON" position and move joystick controls to release pressure in accumulator. Remove key.

## IMPORTANT

**Refer to Shop Manual for service procedures. Do not release any pilot lines until pressure within accumulator has been released.**

## 6. Keep Out of Steering Turn Area (4190-1992A, 190-00120)



**DANGER!**

Keep out of steering turn area.

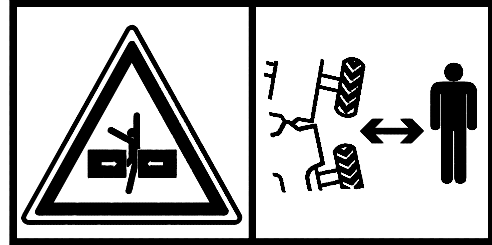

AMO0410L

## 7. Warnings for High Temperature Hydraulic Oil (190-00691, 190-00097)



**WARNING!**

### HYDRAULIC OIL

To prevent hot oil from spurting out:

- Turn engine off.
- Allow oil to cool.
- Slowly loosen cap to relieve pressure before removing.

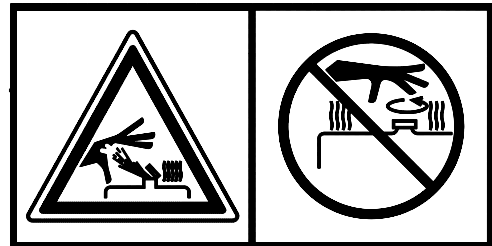

ACO1410L

## 8. Warnings for High Temperature Coolant (190-00692, 190-00097)



### WARNING!

To prevent hot water from spurting out:

- Turn engine "OFF."
- Allow water to cool.
- Slowly loosen cap to relieve pressure before removing.

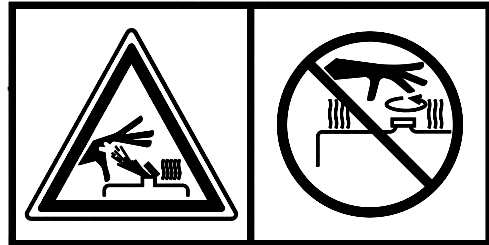

ACO1410L

## 9. Warnings for Battery Maintenance (2190-2533A, 190-00100)



### DANGER!

- Battery fumes can explode. Keep sparks and flames away from batteries.
- Always avoid storing metals like tools or inflammable materials around or on batteries. Explosion or fire can be caused by short circuiting batteries.
- Sulfuric acid in battery is poisonous. It is strong enough to burn skin, eat holes in clothing, and cause blindness if splashed in eyes.

If you spill acid on yourself:

1. Flush your skin with water.
2. Apply baking soda or lime to help neutralize acid.
3. Flush your eyes with water for 10 - 15 minutes.

Get medical attention immediately.

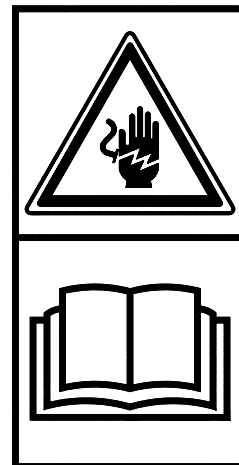

ACO1400L

## 10. Warnings for Performing Maintenance On Front Attachment (4190-2546A, 190-00105)

 **DANGER!**

To avoid injury, securely brace lift arm before disassembly of valve or piping.

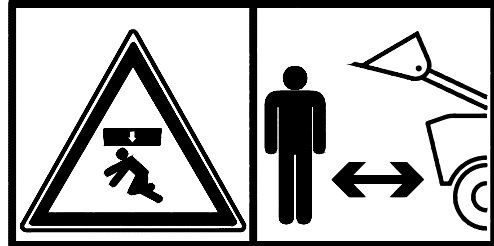

AMO0430L

## 11. Warnings to Use Safety Lock (4190-1993, 190-00121)

 **WARNING!**

Safety lock must be in "LOCK" position when servicing pivot area or transporting machine.

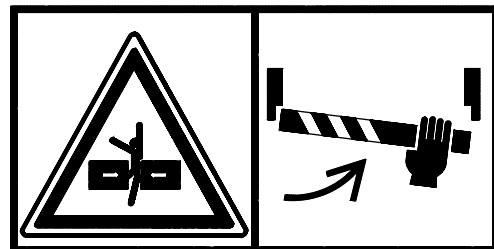

AMO0440L

## 12. Warning Tag (190-00695, 190-00098)



Don't touch when performing inspection or maintenance.

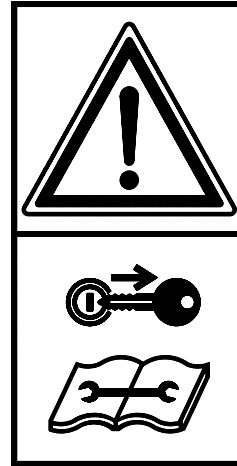

ACO1450L

# UNAUTHORIZED MODIFICATIONS

Any modification made without authorization or written approval from *DOOSAN* can create a safety hazard, for which the machine owner must be held responsible.

For safety's sake, replace all OEM parts with the correct authorized or genuine *DOOSAN* part. For example, not taking the time to replace fasteners, bolts or nuts with the correct replacement parts could lead to a condition in which the safety of critical assemblies is dangerously compromised.

## GENERAL HAZARD INFORMATION

### Safety Rules

Only trained and authorized personnel can operate and maintain the machine.

Follow all safety rules, precautions and instructions when operating or performing maintenance on the machine.

Do not operate the machine if you are not feeling well, if you are taking medication that makes you feel sleepy, if you have been drinking, or if you are suffering from emotional problems. These problems will interfere with your sense of judgement in emergencies and may cause accidents.

When working with another operator or with a person on work site traffic duty, be sure that all personnel know the nature of the work and understand all hand signals that are to be used.

Always observe strictly any other rules related to safety.

### Safety Features

Be sure that all guards and covers are installed in their proper position. Have guards and covers repaired immediately if damaged.

Be sure that you understand the method of use of safety features such as transmission lever neutral lock and the seat belt, and use them properly.

Never remove any safety features. Always keep them in good operating condition.

Failure to use safety features according to the instructions in the Operation and Maintenance Manual could result in serious bodily injury.

## Inside Operator's Compartment

When entering the operator's compartment, always remove all mud and oil from the soles of your shoes. If you operate the accelerator and brake pedals with mud or oil stuck to your shoes, your foot may slip and this may cause a serious accident.

Clean grease and dirt from pedals and controls. This contributes to safe operation. Cleaning also provides an opportunity to inspect equipment. Minor damage can be repaired or corrected before major problems result.

Keep cabin floor and consoles free of tools and personal items.

Do not stick suction pads to the window glass. Suction pads act as a lens and may cause fire.

Do not leave lighters laying around the operator's compartment. If the temperature inside the operator's compartment becomes high, there is danger that the lighter may explode.

Do not use cellular telephones inside the operator's compartment when driving or operating the machine. There is danger that this may lead to an unexpected accident.

Never bring any dangerous objects such as flammable or explosive items into the operator's cabin.

To ensure safety, do not use the radio or music headphones when operating the machine. There is danger that this may lead to a serious accident.

When operating the machine, do not put your hands or head out of the window.

When standing up from the operator's seat, always place transmission neutral lock lever in the "LOCK" position and set pilot cutoff switch to "O" (OFF) position. If you accidentally touch the work equipment levers when they are not locked, the machine may suddenly move and cause serious injury or damage.

When leaving the machine, lower the work equipment completely to the ground, set transmission neutral lock lever in the "LOCK" position, set pilot cutoff switch to "O" (OFF) position, "APPLY" parking brake, and shut down engine. Use the key to lock all the equipment. Always remove the key and take it with you.

## Clothing and Personal Protective Items

Contain long hair, and avoid loose clothing and jewelry. They can catch on controls or in protruding parts and cause serious injury or death.

Do not wear oily clothes. They are highly flammable.

Full eye protection, a hard hat, safety shoes and gloves may be required at the work site.

While working on the machine, never use inadequate tools. They could break or slip, causing injury, or they may not adequately perform intended functions.

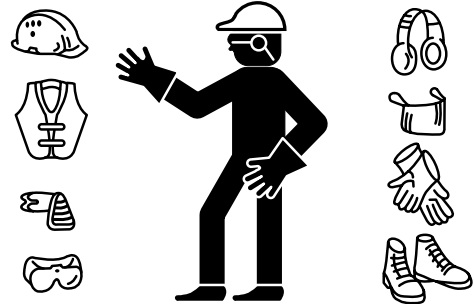

Figure 2

HAOA020L

## Breathing Masks, Ear Protection May Be Required

Do not forget that some risks to your health may not be immediately apparent. Exhaust gases and noise pollution may not be visible, but these hazards can cause disabling or permanent injuries.

**NOTE:** *The equivalent continuous A-weighted sound pressure level at the workstation for this machine is 70 dB(A).*

*Measurement is obtained on a dynamic machine following the procedures and cabin conditions as described in ISO 6396.*

**NOTE:** *The guaranteed sound power level emitted by the machinery for this machine is 105 dB(A).*

*Measurement is obtained on a dynamic machine with the procedures as described in 2000/14/EC.*

## Vibration Level Information

Hands/Arms: The weighted root mean square acceleration to which the hands/arms are subjected, is less than 2.5 m/s<sup>2</sup>.

Whole body: The weighted root mean square acceleration to which the whole body is subjected, is less than 0.5 m/s<sup>2</sup>.

Measurements are obtained on a representative machine, using measuring procedures as described in the following standard: ISO 2631/1, ISO 5349, and SAE J1166.

## Recommendations for Limiting Vibrations

1. Select the right machine, equipment and attachments for a particular application.
2. Replace any damaged seat by a genuine *DOOSAN* part. Keep the seat maintained and adjusted.
  - Adjust the seat and suspension for the weight and size of the operator.
  - Inspect and maintain the suspension and adjustment mechanisms of the seat regularly.
3. Check that the machine is properly maintained.
  - Tire pressure, brakes, steering, linkages, etc.
4. Steer, brake, accelerate, shift gears, move the attachments and load the attachments smoothly.
5. Adjust the machine speed and travel path to reduce the vibration level.
  - Slow down if it is necessary when passing rough terrain.
  - Drive around obstacles and excessive rough terrain conditions.
6. Keep the terrain on work sites where the machine is working and traveling in good condition.
  - Remove any large rocks or obstacles.
  - Fill any ditches and holes.
  - Provide machines for and schedule time to maintain the terrain conditions.
7. Travel over longer distance (e.g. on public roads) at adjusted (medium) speed.
  - Always adjust the speed for preventing bouncing.

## Asbestos Dust Hazard Prevention

Asbestos dust can be HAZARDOUS to your health if it is inhaled. Materials containing asbestos fiber can be present on work site. Breathing air that contains asbestos fiber can ultimately cause serious or fatal lung damage. To prevent lung damage from asbestos fiber, observe following precautions:

- Use a respirator that is approved for use in an asbestos-laden atmosphere.
- Never use compressed air for cleaning.
- Use water for cleaning to keep down the dust.
- Work on the machine or component with the wind at your back whenever possible.



Figure 3

ARO1770L

- Always observe any rules and regulations related to the work site and working environment.

## Mounting and Dismounting

Before getting on or off the machine, if there is any oil, grease, or mud on the handrails, steps, or track shoes, wipe it off immediately. Always keep these parts clean. Repair any damage and tighten any loose bolts.

Never jump on or off the machine. In particular, never get on or off a moving machine. These actions may lead to serious injury.

When getting on or off the machine, always face the machine, and maintain a three-point contact (both feet and one hand or one foot and both hands) with the handholds and steps to ensure that you support yourself securely.

Never hold any control levers when getting on or off the machine.

Never get up from operator's seat or leave operator's station and dismount machine if engine is running.

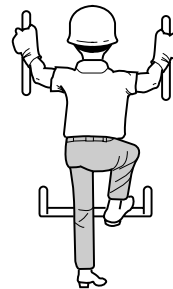

Figure 4

HA301003

## Fuel, Oil and Hydraulic Fluid Fire Hazards

Fuel, oil and antifreeze will catch fire if it is brought close to a flame. Fuel is particularly flammable and can be hazardous.

Always strictly observe the following.

Add fuel, oil, antifreeze and hydraulic fluid to the machine only in a well ventilated area. The machine must be parked with controls, lights and switches turned "OFF." The engine must be "OFF" and any flames, glowing embers, auxiliary heating units or spark causing equipment must be doused, turned "OFF" and/or kept well clear of the machine.

Static electricity can produce dangerous sparks at the fuel filling nozzle. In very cold, dry weather or other conditions that could produce a static discharge, keep the tip of the fuel nozzle in constant contact with the neck of the fuel filling nozzle, to provide a ground.

Keep fuel and other fluid reservoir caps tight and do not start the engine until caps have been secured.



Figure 5

ARO1050S

## Precautions When Handling Fluids at High Temperature

Immediately after operations are stopped, the coolant, engine oil, and hydraulic oil are at high temperature and the radiator and hydraulic tank are still under pressure. Attempting to remove the cap, drain the oil or coolant, or replace the filters may lead to serious burns. Always wait for the temperature to go down, and follow the specified procedures when carrying out these operations.

To prevent hot coolant from spurting out, shut down engine, wait for the coolant to cool, then loosen the cap slowly to relieve the pressure.

To prevent hot oil from spurting out, shut down engine, wait for the oil to cool, then loosen the cap slowly to relieve the pressure.

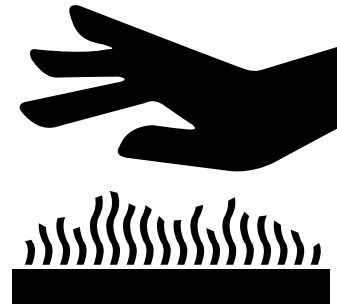

HAOA050L

Figure 6



HAOA060L

Figure 7

## Injury from Work Equipment

Do not enter or put your hand, arm or any other part of your body between movable parts, such as between the work equipment and cylinders, or between the machine and work equipment.

If the control levers are operated, the clearance between the machine and the work equipment will change and this may lead to serious damage or personal injury.

If going between movable parts is necessary, always position and secure the work equipment so that it cannot move.



HDO1010L

Figure 8

## Fire Extinguisher and First Aid Kit

As a precaution if any injury or fire should occur, always do the following.

- Be sure that fire extinguishers have been provided and read the labels to ensure that you know how to use them. It is recommended that an appropriately sized (2.27 kg [5 lb] or larger) multipurpose "A/B/C" fire extinguisher be mounted in the cabin. Check and service the fire extinguisher at regular intervals and make sure that all work site crew members are adequately trained in its use.
- Provide a first aid kit in the storage compartment and keep another at the work site. Check the kit periodically and make any additions if necessary.
- Know what to do in case of injury from fire.
- Keep emergency numbers for doctor, ambulance service, hospital and fire department near your telephone.

If the machine catches fire, it may lead to serious personal injury or death. If a fire occurs during operation, escape from the machine as follows:

- Turn the starter switch to the "O" (OFF) position and shut down engine.
- If there is time, use the fire extinguisher to extinguish as much of the fire as possible.
- Use the handrails and steps to escape from the machine.

The above is the basic method for escaping from the machine, but changing the method may be necessary according to the conditions, so carry out practice drills at the work site.

## Protection from Falling or Flying Objects

On work sites where there is danger that falling objects or flying objects may hit the operator's cabin select a guard to match the operating conditions to protect the operator.

Working in mines, tunnels, deep pits or on loose or wet surfaces could produce danger of falling rock, roll over or hazardous flying objects. Additional protection for operator's cabin could be required in form of a FOPS/Falling Object Protective Structure and/or ROPS/Roll Over Protective Structure reinforcement system.

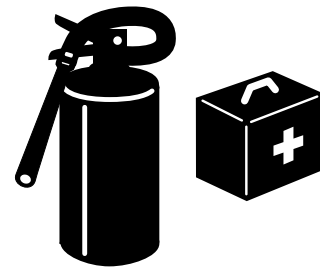

Figure 9

HDO1009L

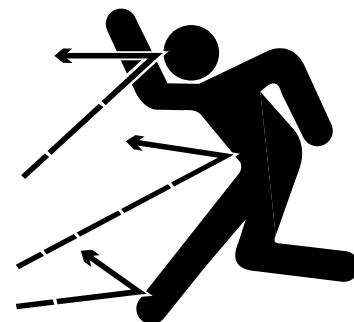

Figure 10

HAOA110L

Any reinforcement system that is installed on machine must pass safety and certification standards and carry appropriate labeling and rating information. For example, most often added type of reinforcement system, FOPS, must meet or exceed Society of Automotive Engineers standard SAE J1356, "Performance Criteria for Falling Object Guards for Wheel loaders."

Never attempt to alter or modify any type of protective structure reinforcement system, by drilling holes, welding, remounting or relocating fasteners. Any serious impact or damage to the system requires a complete integrity reevaluation. Reinstallation, recertification and/or replacement of the system may be necessary.



Figure 11

HAOA100L

## Install Additional Safety Equipment If Conditions Require

Laminate glass protection for the front, side or rear windows, along with tempered glass, may also be recommended depending upon particular site conditions.

Contact your *DOOSAN* distributor for available safety guards and/or recommendations if there is any danger of getting hit by objects that could strike the operator's cabin. Make sure that all other work site crew members are kept well away from wheel loader and safe from potential hazards.

## Maintain Standard Safety Equipment in Good Condition

Machinery guards and body panel covers must be in place at all times. Keep well clear of rotating parts. Pinch point hazards such as cooling fan and alternator drive belts could catch hair, jewelry or oversize or very loose clothing.

Safety labels must be replaced if they are damaged or become unreadable. Information on labels gives work crew members an important safety reminder. Part numbers for each decal and required mounting locations are shown on pages 1-2 through 1-4 of this section.

## Attachment Precautions

Option kits are available through your dealer. Contact *DOOSAN* for information on available 3 spool control valve and log fork piping / valving / auxiliary control kits. Because *DOOSAN* cannot anticipate, identify or test all of the attachments that owners may wish to install on their machines, please contact *DOOSAN* for authorization and approval of attachments, and their compatibility with options kits.

## Accumulator

The pilot control system is equipped with an accumulator. For a brief period of time after the engine has been shut down, the accumulator will store a pressure charge that may enable hydraulic controls to be activated. Activation of any controls may enable the selected function to operate under force of gravity.

When performing maintenance on the pilot control system, the hydraulic pressure in the system must be released as describe in “Handling of Accumulator” on page 4-77.

The accumulator is charged with high-pressure nitrogen gas, so it is extremely dangerous if it is handled in the wrong way. Always observe the following precautions:

- Do not drill or make any holes in the accumulator or expose it any flame, fire or heat source.
- Do not weld on the accumulator, or try attaching anything to it.
- When carrying out disassembly or maintenance of the accumulator, or when disposing of the accumulator, the charged gas must be properly released. Contact your *DOOSAN* distributor.
- Wear safety goggles and protective gloves when working on an accumulator. Hydraulic oil under pressure can penetrate the skin and cause serious injuries.

## Engine Ventilation

Engine exhaust gases can cause loss of judgment, loss of alertness, and loss of motor control. These gases can also cause unconsciousness, serious injury, fatal accidents and death.

Make sure there is adequate ventilation before starting the engine in any enclosed area.

You should also be aware of open windows, doors or ductwork into which exhaust may be carried, or blown by the wind, exposing others to danger.



ARO1770L

Figure 12

# BEFORE STARTING ENGINE

## Work Site Precautions

Before starting operations, thoroughly check the area for any unusual conditions that could be dangerous.

Check the terrain and condition of the ground at the work site, and determine the best and safest method of operation.

Make the ground surface as hard and horizontal as possible before carrying out operations. If there is a lot of dust and sand on the work site, spray water before starting operations.

If you need to operate on a street, protect pedestrians and cars by designating a person for work site traffic duty or by erecting fences and posting "No Entry" signs around the work site.

Erect fences, post "No Entry" signs, and take other steps to prevent people from coming close to or entering the work site. If people come close to a moving machine, they may be hit or caught by the machine, and this may lead to serious personal injury or death.

Water lines, gas lines, phone lines and high voltage electrical lines may be buried under the work site. Contact each utility and identify their locations. Be careful not to damage or cut any of these lines.

Check the condition of the river bed, and the depth and flow of the water before operating in water or crossing a river. NEVER be in water that is in excess of the permissible water depth. Refer to "Allowable Water Depth" on page 3-22.

Any type of object in the vicinity of the boom could represent a potential hazard, or cause the operator to react suddenly and cause an accident. Use a spotter or signal person working near bridges, phone lines, work site scaffolds, or other obstructions.

Minimum levels of insurance coverage, work permits or certification, physical barriers around the work site or restricted hours of operation may be mandated by governing authorities. There may also be regulations, guidelines, standards or restrictions on equipment that may have to be followed for local requirements. There may also be regulations related to performing certain kinds of work. If there is any question about whether your machine and work site complies with the applicable standards and regulations contact your local authorities and agencies.

Avoid entering soft ground. It will be difficult for the machine to escape.

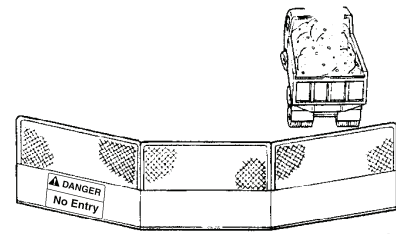

ARO1251L

Figure 13

Avoid operating your machine too close to the edge of cliffs, overhangs, and deep ditches. The ground may be weak in such areas. If the ground should collapse, the machine could fall or tip over and this could result in serious injury or death.

Remember that the soil after heavy rain, blasting or after earthquakes, is weakened in these areas.

Earth laid on the ground and the soil near ditches is loose. It can collapse under the weight of vibration of your machine and cause your machine to tip over.

Install the safety guard if working in areas where there is danger of falling rocks.

## **Checks Before Starting Engine**

Every day before starting the engine for the first time, carry out the following checks. If these checks are not carried out properly, there is danger of serious injury.

Completely remove all wood chips, leaves, grass, paper and other flammable materials accumulated in the engine compartment and around the battery. They could cause a fire. Remove any dirt from the window glass, mirrors, handrails, and steps.

Do not leave tools or spare parts laying around in the operator's compartment. The vibration of the machine when traveling or during operations may cause them to fall and damage or break the control levers or switches. They may also get caught in the gap of the control levers and cause the work equipment to malfunction or move dangerously. This may lead to unexpected accidents.

Check the coolant level, fuel level, and hydraulic tank oil level, and check for clogged air cleaner and damage to the electrical wiring.

Adjust the operator's seat to a position where it is easy to operate the machine, and check the seat belt and mounts for damage and wear.

Check the operation of the gauges and the angle of the mirrors, and check that the safety lever is in "LOCKED" position.

If any abnormalities are found in the above checks, carry out repairs immediately.

## Engine Starting

Walk around your machine before getting in the operator's cabin. Look for evidence of leaking fluid, loose fasteners, misaligned assemblies or any other indications of possible equipment hazard.

All equipment covers and machinery safety guards must be in place, to protect against injury while the machine is being operated.

Look around the work site area for potential hazards, people or property that could be at risk while operation is in progress.

NEVER start the engine if there is any indication that maintenance or service work is in progress, or if a warning tag is attached to controls in the cabin.

A machine that has not been used recently, or is being operated in extremely cold temperatures, could require a warm-up or maintenance service before start-up.

Check gauges and monitor displays for normal operation before starting the engine. Listen for unusual noises and remain alert for other potentially hazardous conditions at the start of the work cycle.

Check tire inflation and check tires for damage or uneven wear. Perform maintenance before operation.

Do not short circuit the starting motor to start the engine. This is not only dangerous, but may also damage the machine.

When starting the engine, sound the horn as an alert.

Start and operate the machine only while seated.

## Before Operating Machine

If checks are not carried out properly after starting the engine, it may result in a delay in discovering abnormalities in the machine, and this may lead to personal injury or damage to the machine.

Carry out the checks in an open area where there are no obstructions. Do not let anyone near the machine when carrying out the checks.

- Check the operating condition of the equipment, and the actuation of the bucket, boom, and travel systems.
- Check the machine for any abnormal noise, vibration, heat, smell, or abnormality with the gauges. Check also for leakage of air, oil, and fuel.
- If any abnormality is found, repair the problem immediately. If the machine is used without repairing the problems, it may lead to unexpected injury or failure.
- Clear all personnel from directly around machine and from the area.
- Clear all obstacles from the machine's path. Beware of hazards.
- Be sure that all windows are clean. Secure the doors and the windows in the open position or in the shut position.
- Adjust the rear view mirrors for best visibility close to the machine. Make sure that the horn, the travel alarm (if equipped), and all other warning devices are working properly.
- Fasten the seat belt securely.
- Warm up the engine and hydraulic oil before operating machine.

# MACHINE OPERATION

---

## IMPORTANT

---

If you need more information or have any questions or concerns about safe operating procedures or working the wheel loader correctly in a particular application or in the specific conditions of your individual operating environment, please consult your local **DOOSAN** representative.

---

### Operate While Seated at Operator's Station Only

Never reach in through a window to work a control. Do not try to operate wheel loader unless you're in command position - seated at controls. You should stay alert and focused on your work at all times. Do not twist out of seat if job activity behind you (or to the side) requires your attention.

Use a spotter or signal person if you cannot see clearly and something is happening behind you.

Replace damaged safety labels and lost or damaged operator's manuals.

Do not let anyone operate machine unless they've been fully and completely trained, in safety and in operation of the machine.

### Seat Belts Must Be Used at All Times

Whenever engine is running, operator must be seated at the control station with seat belt properly engaged.



HAOA151L

Figure 14



HAOD060P

Figure 15

### Movement Alarms

If wheel loader is equipped with an audible travel movement alarm, test alarm on a daily basis. Audible alarm should sound as soon as travel system is engaged.

## Travel Precautions

When traveling, wheel loader always keeps lights on; make sure that you are in compliance with all state and local regulations concerning warning flags and signs.

Never turn the starter switch to the "O" (OFF) position when traveling. It is dangerous if the engine stops when the machine is traveling. It will be impossible to operate the steering unless the unit is equipped with an emergency steering system.

Pilot control valve lever (joystick) should not be operated while traveling.

Lower work equipment so that it is 400 mm (16 in) above ground.

Never travel over obstacles or slopes that will cause machine to tilt severely. Travel around any slope or obstacle that causes 10° tilt, or more.

Do not operate the steering suddenly. The work equipment may hit the ground and cause the machine to lose its balance, and this may damage the machine or structures in the area.

When traveling on rough ground, travel at low speed, and avoid sudden changes in direction.

Always keep to the permissible water depth. Refer to "Allowable Water Depth" on page 3-22.

When traveling over bridges or structures on private land, check first that the bridge or structure can withstand the weight of the machine. When traveling on public roads, check with the local authorities and follow their instructions.

## Sloping Terrain Requires Caution

Dig evenly around work site whenever possible, trying to gradually level any existing slope. If it's not possible to level area or avoid working on a slope, reducing size and cycling rate workload is recommended.

On sloping surfaces, use caution when positioning wheel loader before starting a work cycle. Stay alert for unstable situations to avoid getting into them. For example, you should always avoid working bucket over downhill side of machine when parked perpendicular to slope. Avoid full extensions of bucket in a downhill direction. Lifting bucket too high, too close to machine, while wheel loader is turned uphill can also be hazardous.

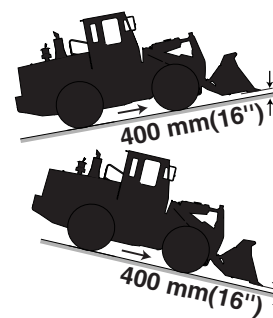

AHO0970L

Figure 16

## Avoid High Voltage Cables

Serious injury or death can result from contact or proximity to high voltage electric lines. The bucket does not have to make physical contact with power lines for current to be transmitted.

Use a spotter and hand signals to stay away from power lines not clearly visible to operator.

Voltage	Minimum Safe Distance
6.6 kV	3 m (9' 10")
33.0 kV	4 m (13' 1")
66.0 kV	5 m (16' 5")
154.0 kV	8 m (26' 3")
275.0 kV	10 m (32' 10")

Use these minimum distances as a guideline only. Depending upon voltage in line and atmospheric conditions, strong current shocks can occur with boom or bucket as far away as 4 - 6 m (13 - 20 ft) from power line. Very high voltage and rainy weather could further decrease that safety margin.

**NOTE:** *Before starting any type of operation near power lines (either above ground or buried cable type) you should always contact power utility directly and work out a safety plan with them.*

## Before Starting to Dig, Contact Authorities

Below ground hazards also include natural gas lines, water mains, tunnels and buried foundations. Know what's underneath work site before starting to dig.

## Be Aware of Height Obstacles

Any type of object in vicinity of boom could represent a potential hazard, or cause operator to react suddenly and cause an accident. Use a spotter or signal person working near bridges, phone lines, work site scaffolds, or other obstructions.

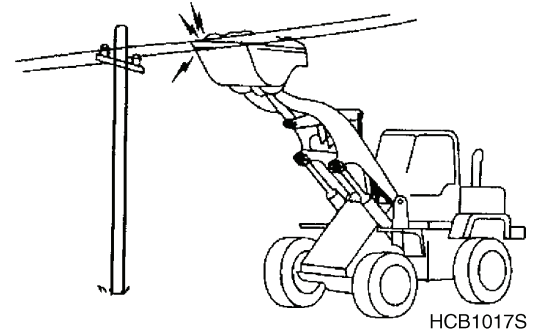

Figure 17

HCB1017S

## Use Care on Loose Support

Working heavy loads over loose, soft ground or uneven, broken terrain can cause dangerous side load conditions and possible tipover and injury. Travel without a load or balanced load may also be hazardous.

If temperatures are changing, be cautious of dark and wet patches when working or traveling over frozen ground. Stay away from ditches, overhangs and all other weak support surfaces. Halt work and install support mats or blocking if work is required in an area of poor support.

## Use Solid Support Blocking

Never rely on lift jacks or other inadequate supports when work is being done. Block wheels fore and aft to prevent any movement.

## Digging Beneath Overhangs

Digging beneath an overhang is dangerous. Overhang could collapse on top of operator and cause serious injury or death. Go on to another digging area before steep overhangs are formed. Know height and reach limits of wheel loader and plan ahead while working. Park wheel loader away from overhangs before work shut down.

## Digging Beneath Wheel Loader

Digging beneath wheel loader is dangerous. Earth beneath could collapse. This could cause wheel loader to tip, which could cause serious injury or death to operator. Working around deep pits, trenching or along high walls may require support blocks, especially after heavy rainfalls or during spring thaws.

## Stay Alert for People Moving Through Work Area

When loading a truck you should always know where the driver is.

Avoid loading over the cabin of a truck even if the driver is in a safe spot. Someone else could have gone inside, for any number of reasons. Avoid working where unseen passersby might be.

Slow down work cycle and use slower travel speeds in congested or populated areas. Use a commonly understood signal so that other members of work crew can warn operator to slow or halt work in an impending hazardous situation.

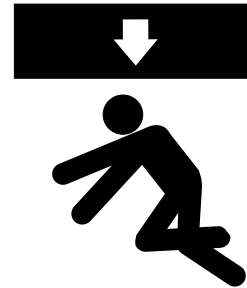

Figure 18

HDO1042L



Figure 19

HAOA171L

## Be Aware of and Conform to Local Regulations

Minimum levels of insurance coverage, work permits or certification, physical barriers around work site or restricted hours of operation may be mandated by governing authorities. There may also be guidelines, standards or restrictions on equipment that may be used to perform certain kinds of work. Check and follow all local requirements, which may also be related to below ground hazards and power lines.

## Never Use Ether Starting Aids

An electric grid type manifold heater is used for cold starting. Glowing heater element can cause ether or other starting fluid to detonate, causing injury.



HAOA311P

Figure 20

## Observe General Safety Rules

Only trained and authorized personnel, with a good knowledge and awareness of safe procedures, may be allowed to operate or perform maintenance or service on wheel loader.

All personnel at work site must be aware of assigned individual responsibilities and tasks. Communication and hand signals used must be understood by everyone.

Terrain and soil conditions at work site, approaching traffic, weather related hazards and any above or below ground obstacles or hazards must be observed and monitored by all work crew members.

## Take Time to Provide Good Visibility

Be careful not to go close to the edge of a cliff by mistake.

Use the machine only for its main purpose. Using it for other purposes will cause failures.

To ensure an ample view, do as follows:

- When working in dark areas, attach working lights and front lights to the machine. If necessary, set up lighting at the work site.
- Stop operations when the visibility is poor, such as in fog, mist, snow, and rain. Wait for the visibility to improve to a level which causes no problems for the operation.
- Keep dirt and dust off of windows and off lens surfaces of work lights. Stop working if lights, windows or mirrors need cleaning or adjustment.

To avoid hitting the work equipment, always do the following:

- When working in tunnels, on bridges, under electric wires, or when parking the machine or carrying out other operations in places with limited height, be extremely careful not to hit the bucket or other parts.
- To prevent collisions, operate the machine at a safe speed when working in confined spaces, indoors, or in crowded areas.
- Do not pass the bucket over the heads of workers or over the operator's compartment of dump truck.

## Keep "Pinch Point" Areas Clear - Use Caution in Reverse

Use a signal person in high traffic areas and whenever operator's view is not clear, such as when traveling in reverse.

Anyone standing near wheels, or working assemblies of the attachment, is at risk of being caught between moving parts of machine.

Never allow anyone to ride on any part of machine or attachment, including any part of operator's cabin.

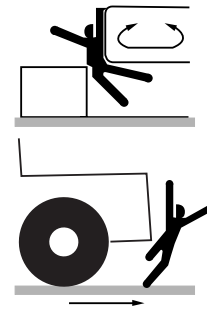

Figure 21

HAOA191L

## **Operate Carefully on Snow and Ice, In Very Cold Temperatures**

In icy cold weather avoid sudden travel movements and stay away from even very slight slopes. The machine could skid off to one side very easily.

Snow accumulation could hide or obscure potential hazards. Use care while operating or while using the machine to clear snow.

Warming up the engine for a short period may be necessary, to avoid operating with sluggish or reduced working capacity. The jolting shocks and impact loads caused by bumping or bottoming the boom or attachment are more likely to cause severe stress in very cold temperatures. Reducing work cycle rate and work load may be necessary.

When the temperature rises, frozen road surfaces become soft, so the machine travel becomes unstable.

In cold weather, do not touch metal surfaces with your bare hands. If you touch a metal surface in extremely cold weather, your skin may freeze to the metal surface.

## **Parking Machine**

Avoid making sudden stops, or parking the machine wherever it happens to be at the end of the work day. Plan ahead so that the wheel loader will be on firm, level ground away from traffic and away from high walls, cliff edges and any area of potential water accumulation or runoff. If parking on inclines is unavoidable, block the wheels to prevent movement. Lower the bucket or other working attachment completely to the ground, or to an overnight support saddle. There must be no possibility of unintended or accidental movement.

When parking on public roads, provide fences, signs, flags, or lights, and put up any other necessary signs to ensure that passing traffic can see the machine clearly, and park the machine so that the machine, flags, and fences do not obstruct traffic.

## Shutdown Control Functions

After bucket has been lowered to overnight storage position, move all switches and controls to "OFF" position. Pull parking brake knob to "APPLIED" position. This will apply parking brake. Move pilot cutoff switch to "LOCK" position. This will disable pilot control valve lever (joystick). Move key in starter switch to "OFF" position, and remove key from switch.

Engage all lock-down security equipment that may have been installed on machine.

---

## IMPORTANT

---

When hydraulic system maintenance or service work must be performed, be aware that accumulators in system store fluid under pressure after system has been shut down. To release hydraulic pressure in accumulators, operate control with engine "OFF" until accumulator pressure is completely dissipated.

---

## Never Let Anyone Ride on Attachment

Never let anyone ride on any work attachment, such as the bucket, crusher, grapple, or clamshell (grab bucket). There is a danger of the person falling and suffering serious injury.



Figure 22

HAAD4050

# MAINTENANCE

## Use Warning Tag During Service

Alert others that service or maintenance is being performed and tag operator's cabin controls - and other machine areas if required - with a warning notice.

Warning tags for controls are available from *DOOSAN* distributors; see Figure 23.



HAOC920L

Figure 23

## Clean Before Inspection or Maintenance

Clean the machine before carrying out inspection and maintenance. This prevents dirt from getting into the machine and also ensures safety during maintenance.

If inspection and maintenance are carried out when the machine is dirty, it will become more difficult to locate the problems, and also there is danger that you may get dirt or mud in your eyes or that you may slip and injure yourself.

When washing the machine, do the following:

- Wear shoes with nonslip soles to prevent yourself from slipping and falling on wet places.
- Wear safety glasses and protective clothing when washing the machine with high-pressure steam.
- Take action to prevent touching high-pressure water and cutting your skin or having mud fly into your eyes.
- Do not spray water directly on electrical components (sensors, connector) (1, Figure 24). If water gets into the electrical system, there is danger that it will cause defective operation and malfunction.

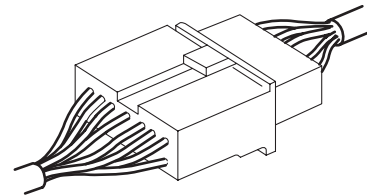
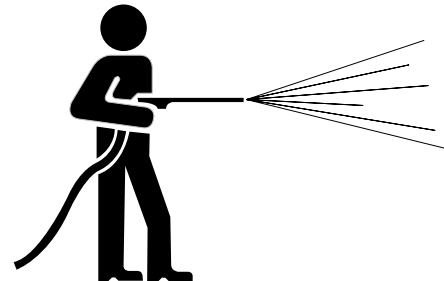

ARO1330L

Figure 24

Pick up any tools or hammers that are laying in the work place, wipe up any grease or oil or any other slippery substances, and clean the area to make it possible to carry out the operation in safety. If the work place is left untidy, you may trip or slip and suffer injury.

## Proper Tools

Use only tools suited to the task. Using damaged, low quality, faulty, or makeshift tools could cause personal injury. There is danger that pieces from, chisels with crushed heads, or hammers, may get into your eyes and cause blindness.

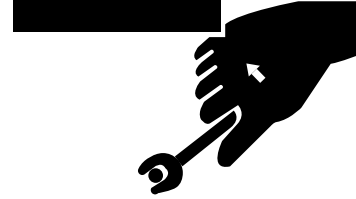

Figure 25

HDO1037L

## Use of Lighting

When checking fuel, oil, battery electrolyte, or window washing fluid, always use lighting with antiexplosion specifications. If such lighting equipment is not used, there is danger of an explosion.

If work is carried out in dark places without using lighting, it may lead to injury, so always use proper lighting.

Even if the place is dark, never use a lighter or flame instead of lighting. There is danger of fire. There is also danger that the battery gas may catch fire and cause an explosion.



Figure 26

HDO1040L

## Fire Prevention and Explosion Prevention

All fuels, most lubricants and some coolant mixtures are flammable. Leaking fuel or fuel that is spilled onto hot surfaces or onto electrical components can cause a fire.

Store all fuels and all lubricants in properly marked containers and away from all unauthorized persons.

Store oily rags and other flammable material in a protective container.

Do not smoke while you refuel the machine or while you are in a refueling area.

Do not smoke in battery charging areas or in areas that contain flammable material.

Clean all electrical connections and tighten all electrical connections. Check the electrical wires daily for wires that are loose or frayed. Tighten all loose electrical wires before you operate the machine. Repair all frayed electrical wires before you operate the machine.

Remove all flammable materials before they accumulate on the machine.



Figure 27

HDO1015I

Do not weld on pipes or on tubes that contain flammable fluids. Do not flame cut on pipes or on tubes that contain flammable fluids. Before you weld on pipes or on tubes or before you flame cut on pipes or on tubes, clean the pipes or tubes thoroughly with a nonflammable solvent.

## Burn Prevention

When checking the radiator coolant level, shut down engine, let the engine and radiator cool down, then check the coolant recovery tank. If the coolant level in the coolant recovery tank is near the upper limit, there is enough coolant in the radiator.

Loosen the radiator cap gradually to release the internal pressure before removing the radiator cap.

If the coolant level in the coolant recovery tank is below the lower limit, add coolant.

Cooling system conditioner contains alkali. Alkali can cause personal injury. Do not allow alkali to contact the skin, the eyes, or the mouth.

Allow cooling system components to cool before you drain the cooling system.

Hot oil and hot components can cause personal injury. Do not allow hot oil or hot components to contact the skin.

Remove the hydraulic tank filter plug only after the engine has been stopped. Make sure that the hydraulic tank filter plug is cool before you remove it with your bare hand. Remove the hydraulic tank filter plug slowly to relieve pressure.

Relieve all pressure in the hydraulic oil system, in the fuel system, or in the cooling system before you disconnect any lines, fittings, or related items.

Batteries give off flammable fumes that can explode.

Do not smoke while you are checking the battery electrolyte levels.

Electrolyte is an acid. Electrolyte can cause personal injury. Do not allow electrolyte to contact the skin or the eyes.

Always wear protective glasses when you work on batteries.

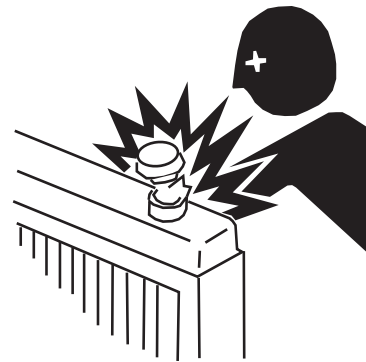
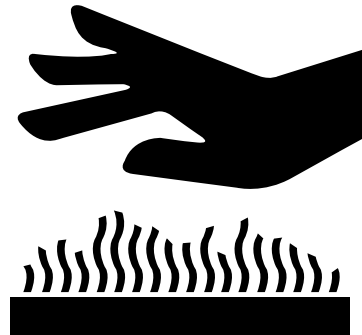

HAAE1980

Figure 28

## Welding Repairs



### CAUTION!

When you connect or disconnect connectors between ECU and Engine or connector between ECU and the machine, always disconnect the source power to protect damage of the ECU.

If you don't observe this procedure, the ECU would be damaged or the engine would operate abnormally.

When carrying out welding repairs, carry out the welding in a properly equipped place. The welding should be performed by a qualified worker. During welding operations, there is the danger of, generation of gas, fire, or electric shock, so never let an unqualified worker do welding.

The qualified welder must do the following:

- To prevent explosion of the battery, disconnect the battery terminals and remove batteries.
- To prevent generation of gas, remove the paint from the location of the weld.
- If hydraulic equipment, piping or places close to them are heated, a flammable gas or mist will be generated and there is danger of it catching fire. To avoid this, never subject these places to heat.
- Do not weld on pipes or on tubes that contain flammable fluids. Do not flame cut on pipes or on tubes that contain flammable fluids. Before you weld on pipes or on tubes or before you flame cut on pipes or on tubes, clean the pipes or tubes thoroughly with a nonflammable solvent.
- If heat is applied directly to rubber hoses or piping under pressure, they may suddenly break so cover them with a fireproof covering.
- Wear protective clothing.
- Make sure there is good ventilation.
- Remove all flammable objects and provide a fire extinguisher.

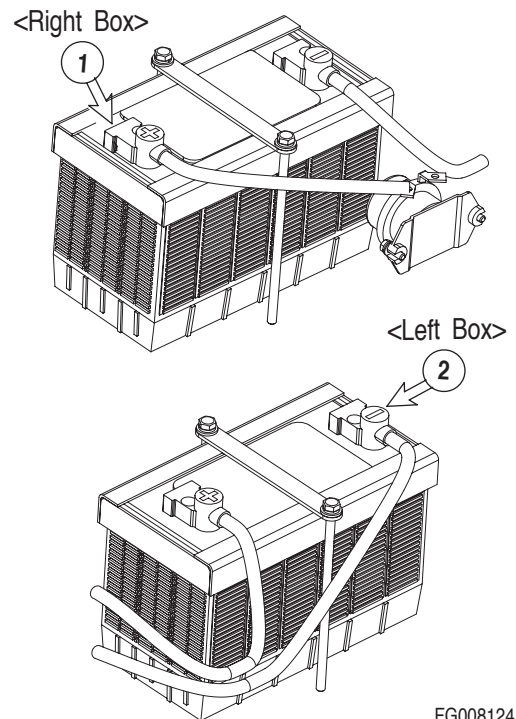

Figure 29

FG008124

## Treatment for Electrical Welding to the Body Structure

To prevent damage to ECU by electrical welding, please observe the following procedures.:

1. Open the cover of the battery box.
2. Detach the positive and negative terminal (Figure 29, 1 and 2) of cable from the battery.
3. Open the side cover and detach the connector (Figure 30, 1) from the ECU that are installed at the engine.
4. Proceed with welding.

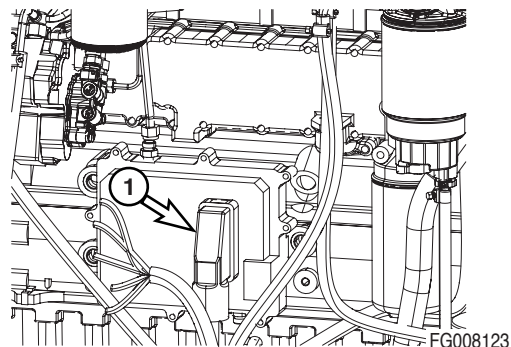

Figure 30

## Precautions for Removal, Installation, and Storage of Attachments

Before starting removal and installation of attachments, decide the team leader.

Do not allow anyone except the authorized workers close to the machine or attachment.

Place attachments that have been removed from the machine in a safe place so that they do not fall. Put up a fence around the attachments and take other measures to prevent unauthorized persons from entering.



Figure 31

HDO1041L

## Precautions When Working on Machine

When carrying out maintenance operations on the machine, keep the area around your feet clean and tidy to prevent you from falling. Always do the following:

- Do not spill oil or grease.
- Do not leave tools laying about.
- Watch your step when walking.

Never jump down from the machine. When getting on or off the machine, use the steps and handrails, and maintain a three-point contact (both feet and one hand or both hands and one foot) to support yourself securely.

If the job requires it, wear protective clothing.

To prevent injury from slipping or falling, when working on the hood or covers, never use any part except the inspection passage fitted with nonslip pads.



Figure 32

ARO1380L

## **Lock Inspection Covers**

When carrying out maintenance with the inspection cover open, lock the cover securely in position with the lock bar.

If maintenance work is carried out with the inspection cover open but not locked, there is danger that it may suddenly close and cause injury if there is a gust of wind.

## **Crushing Prevention and Cutting Prevention**

You should always have at least two people working together if the engine must be run during service. One person needs to remain in the operator's seat, ready to work the controls or stop the machine and shut off the engine.

Unless you are instructed otherwise, never attempt adjustments while the machine is moving or while the engine is running.

Stay clear of all rotating parts and moving parts.

Keep objects away from moving fan blades. The fan blades will throw objects and the fan blades can cut objects.

Do not use a wire rope cable that is kinked or flayed. Wear gloves when you handle a wire rope cable.

When you strike a retainer pin, the retainer pin might fly out. The loose retainer pin can injure personnel. Make sure that the area is clear of people when you strike a retainer pin. To avoid injury to your eyes, wear protective glasses when you strike a retainer pin.

## **Do Not Run Engine If Repairs or Work Are Being Performed Alone**

You should always have at least two people working together if engine must be run during service. One person needs to remain in operator's seat, ready to work controls or stop machine and shut "OFF" engine.

## **Always Use Adequate Equipment Supports and Blocking**

Do not allow weight or equipment loads to remain suspended. Lower everything to ground before leaving operator's seat. Do not use hollow, cracked or unsteady, wobbling weight supports. Do not work under any equipment supported solely by a lift jack.

## Do Not Work on Hot Engines or Hot Cooling or Hydraulic Systems

Wait for engine to cool off after normal operation. Park wheel loader on firm, level ground and lower all equipment before shutting down and switching "OFF" controls. When engine lube oil, gearbox lubricant or other fluids require change, wait for fluid temperatures to decrease to a moderate level before removing drain plugs.

**NOTE:** *Oil will drain more quickly and completely if it is warm. Do not drain fluids at temperatures exceeding 95°C (203°F), however do not allow full cool down.*

## Hydraulic Cylinder Seals Require Periodic Replacement

Check cylinder drift rate at regular intervals. Overhaul seal kits are available through *DOOSAN*.

## High-pressure Hydraulic Lines Can Store a Great Deal of Energy

Exposed hydraulic hoses on arm could react with explosive force if struck by a falling rock, overhead obstacle or other work site hazard. Extra safety guards may be required. NEVER allow hoses to be hit, bent or interfered with during operation.

## Cool Down Is Required Before Radiator or Reservoir Checks

Shut down engine and allow heat to dissipate before performing service on engine radiator or hydraulic fluid reservoir. Both assemblies have air vent levers at or near fill cap for venting built-up air pressure. Release levers before trying to take off fill caps and **LOOSEN CAPS SLOWLY**, before removal.



Figure 33

HAA060L

## Precautions with High-pressure Line, Tubes and Hoses

When inspecting or replacing high-pressure piping or hoses, check that the pressure has been released from the circuit. Failure to release the pressure may lead to serious injury. Always do the following:

- Wear protective glasses and leather gloves.
- Fluid leaks from hydraulic hoses or pressurized components can be difficult to see but pressurized oil has enough force to pierce the skin and cause serious injury. Always use a piece of wood or cardboard to check for suspected hydraulic leaks. Never use your hands or expose your fingers.
- Do not bend high-pressure lines. Do not strike high-pressure lines. Do not install lines, tubes or hoses that are bent or damaged.
- Make sure that all clamps, guards and heat shields are installed correctly to prevent vibration, rubbing against other parts, and excessive heat during operation.
  - If any of the following conditions are found, replace the part.
  - Damage or leakage from hose end.
  - Wear, damage, cutting of covering, or exposure of strengthening wire layer.
  - Cover portion is swollen in places.
  - There is twisting or crushing at movable parts of hose.
  - Foreign material is embedded in the covering.
  - Hose end is deformed.

**NOTE:** Refer to “Hose In-service Lifetime Limit (European Standard ISO 8331 and EN982 CEN)” on page 4-70, for additional European regulations.

### Obtain Immediate Medical Attention if Pressurized Oil Pierces Skin.



## WARNING!

---

Failure to obtain prompt medical assistance could result in gangrene or other serious damage to tissue.

---

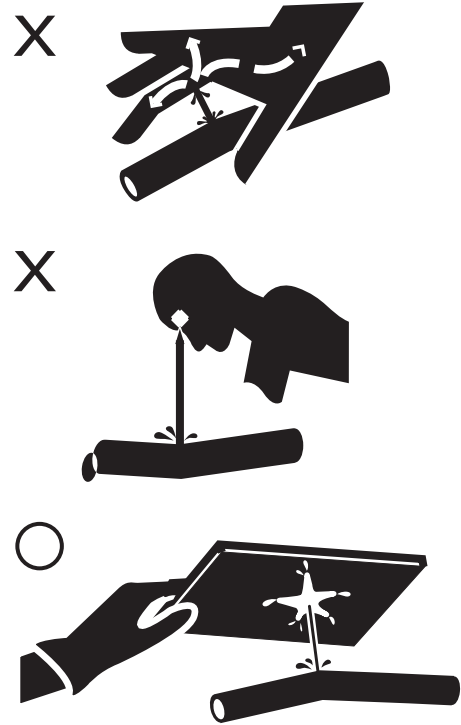

Figure 34

HDO1045I

## Use Correct Replacement Fasteners Tightened to Proper Torque

Refer to "General Maintenance" section of Shop Manual for information on tightening torques and recommended assembly compounds and always use correct part.

Poor or incorrect fastener connections can dangerously weaken assemblies.

## Safety Critical Parts Must Be Replaced Periodically

Replace following fire related components as soon as they begin to show any sign of wear, or at regular periodic intervals, whether or not deterioration is visible:

- Fuel system flexible hoses, the tank overflow drain hose and the fuel fill cap.
- Hydraulic system hoses, especially the pump outlet lines and front and rear pump branch hoses.
- Keep mounting brackets and hose and cable routing straps tight. Hose routing should have gradual bends.

## Dispose of All Petroleum Based Oils and Fluids Properly

Physical contact with used motor oil may pose a health risk. Wipe oil from your hands promptly and wash off any remaining residue.

Used motor oil is an environmental contaminant and may only be disposed of at approved collection facilities. To prevent pollution of the environment, always do the following:

- Never dump waste oil in a sewer system, rivers, etc.
- Always put oil drained from your machine in containers. Never drain oil directly onto the ground.
- Obey appropriate laws and regulations when disposing of harmful materials such as oil, fuel, solvent, filters, and batteries.

## Check Tire Pressure and Condition

Maintain tire pressure but do not overinflate. Inspect tires and wheels daily. When inflating tires, follow procedures in Maintenance Section, which include using an extension to allow you to avoid standing in front of or over a tire. Do not change a tire unless you have both experience and proper equipment.

**NOTE:** Refer to "Recommended Air Pressure" on page 4-88

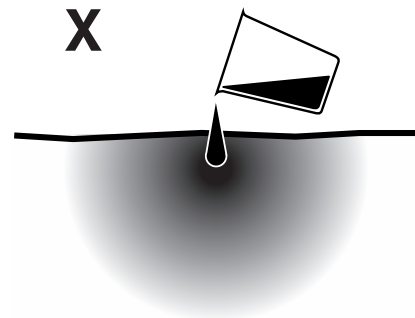

Figure 35

HAOA470L

## Decreasing Risk of Injuries or Death From Boom and Bucket

---



---

When operating machine or making repairs, never allow bystanders in the operational zone or repair area. Operation and service personnel must be careful when working around the machine, especially around the boom and bucket.

An unexpected fall of the front structure may cause injuries or death.

---

1. While operating a machine, do not let people enter the operational area. The sudden collapse of the front structure caused from a hose failure may result in injuries or death.

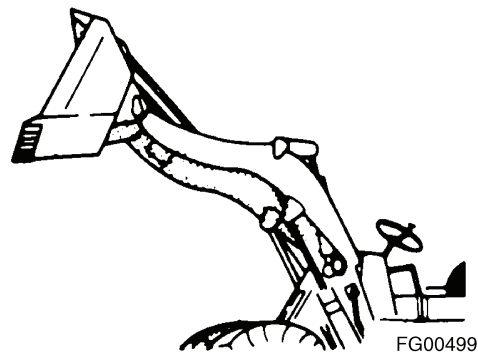

Figure 36

2. When stopping or parking the machine, lower the front structure to the ground. If not, the sudden collapse of the front structure caused from a hose failure may result in injuries or death.

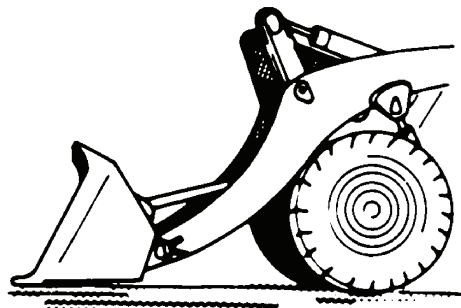

Figure 37

- When repairing or inspecting the machine, with the front structure raised in the air, firmly support the front structure. When installing the supporting structure, verify that it can handle the load.

High-pressure loads between the boom structure and support may cause the support to slip, causing the boom to collapse, leading to injuries or death. Take the installation location of support and supporting surface into consideration.

A supporting structure must be used, when disconnecting front hoses or removing any other mechanical component related to the front structure. High-pressure oil can be ejected from the front cylinder to release its static pressure and force. A sudden shift of a front structure load may cause a boom collapse leading to injuries or death.



## **WARNING!**

---

**Pressurized oil has enough force to pierce the skin and cause a serious injury.**

---

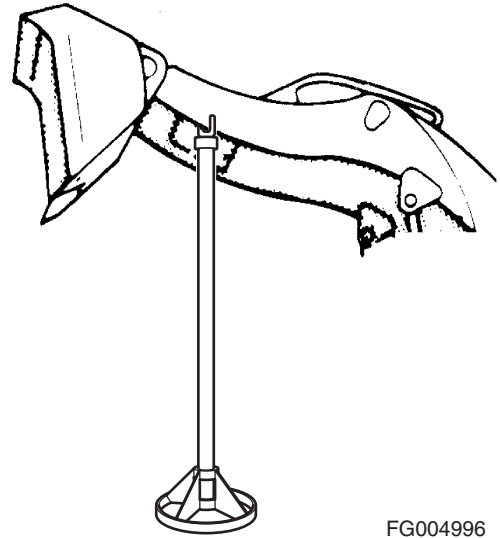

**Figure 38**

FG004996

# BATTERY

## Battery Hazard Prevention

Battery electrolyte contains diluted sulfuric acid and batteries generate hydrogen gas. Hydrogen gas is highly explosive, and mistakes in handling them can cause serious injury or fire. To prevent problems, always do the following:

- Do not smoke or bring any flame near the battery.
- When working with batteries, ALWAYS wear safety glasses and rubber gloves.
- If you spill battery electrolyte on yourself or your clothes, immediately flush the area with water.
- If battery electrolyte gets into your eyes, flush them immediately with large quantities of water and see a doctor at once.
- If you accidentally drink battery electrolyte, drink a large quantity of water or milk, raw egg or vegetable oil. Call a doctor or poison prevention center immediately.
- When cleaning the top surface of the battery, wipe it with a clean, damp cloth. Never use gasoline, thinner, or any other organic solvent or detergent.
- Tighten the battery caps securely.
- Explosive battery gas can be set off by sparks from accidental contact or static discharge. Turn "OFF" all switches and engine when working on batteries. Keep battery terminals tight. Contact between a loose terminal and post can create an explosive spark.
- If the battery electrolyte is frozen, do not charge the battery or start the engine with power from another source. There is danger that the battery may catch fire.
- When charging the battery or starting with power from another source, let the battery electrolyte melt and check that there is no leakage of battery electrolyte before starting the operation.
- Always remove the battery from the machine before charging.

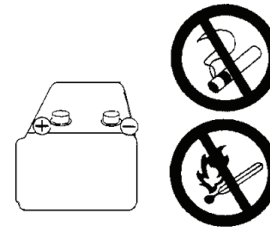
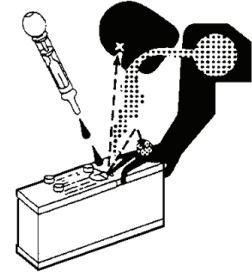

Figure 39

HAAE2100

## Disconnect Batteries Before Electrical Service or Electrical Welding

Remove cable to negative terminal first when disconnecting cable. Connect positive terminal cables first when installing a battery.

## Use Low Heat Portable Lighting

Hot surfaces on trouble lights or portable work lights can set off fuel or battery explosive gases.

## Boost Starting or Charging Engine Batteries

If any mistake is made in the method of connecting the booster cables, it may cause an explosion or fire. Always do the following:

- Turn off all electrical equipment before connecting leads to the battery. This includes electrical switches on the battery charger or boost starting equipment.
- When boost starting from another machine or vehicle do not allow the two machines to touch. Wear safety glasses or goggles while required battery connections are made.
- 24 volt battery units consisting of two series connected twelve volt batteries have a cable connecting one positive terminal on one of the 12 volt batteries to a negative terminal on the other battery. Booster or charger cable connections must be made between the nonseries connected positive terminals and between the negative terminal of the booster battery and the metal frame of the machine being boosted or charged. Refer to the procedure and illustration in "Starting with Auxiliary Batteries" on page 3-8 of this manual.
- Connect positive cable first when installing cables and disconnect the negative cable first when removing them. The final cable connection, at the metal frame of the machine being charged or boost started, must be as far away from the batteries as possible.

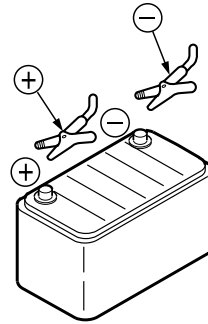

Figure 40

HAOA310L

# TOWING

## Precautions When Towing

If any mistake is made in the method of selecting or inspecting the towing wire or in the method of towing, it may lead to serious personal injury. Always do the following:

- Always use the method of towing given in this Operation and Maintenance Manual. Do not use any other method.
- Use leather gloves when handling the wire rope.
- When carrying out the preparation work for towing with two or more workers, determine the signals to use and follow these signals correctly.
- If the engine on the problem machine will not start or there is a failure in the brake system, always contact your *DOOSAN* distributor.
- Never go between the towing machine and the towed machine during the towing operation.
- It is dangerous to carry out towing on slopes, so select a place where the slope is gradual. If there is no place where the slope is gradual, carry out operations to reduce the angle of the slope before starting the towing operation.
- When towing a problem machine, always use a wire rope with a sufficient towing capacity.
- Do not use a frayed, kinked rope or a rope with any loss of diameter.

# SHIPPING AND TRANSPORTATION

## Obey State and Local Over-the-Road Regulations

Check state and local restrictions regarding weight, width and length of a load before making any other preparation for transport.

The hauling vehicle, trailer and load must all be in compliance with local regulations governing the intended shipping route.

Partial disassembly or teardown of wheel loader may be necessary to meet travel restrictions or particular conditions at the work site.

Refer to "Transportation" on page 5-1, of this Operation and Maintenance Manual for information on loading, unloading and towing.

# Operating Controls

The "Operating Controls" section presented here consists of the following groups:

1. "Component Locations" on page 2-2
2. "Operator's Area" on page 2-4
3. "Steering Console and Pedals" on page 2-5
4. "Front Instrument Panel" on page 2-14
5. "Right Side Switch Panel" on page 2-25
6. "Various Cabin Locations" on page 2-41
7. "Heater and Air Conditioner Operation" on page 2-45
8. "Stereo / CD Player (Optional)" on page 2-50
9. "Seat Adjustment" on page 2-52
10. "Seat Belt" on page 2-54
11. "Door Side Latch" on page 2-55
12. "Arm Rest" on page 2-56
13. "Fuse Box/Relay/Engine Emergency Stop Switch" on page 2-57

Each group is explained with a point location drawing or photo and a brief description of each control, switch, gauge or valve.

Indicator lights work besides the gauges on the instrument panel. The operator should monitor machine pressure on the instrument panel along with indicator lights. These lights will only show that there is a problem.



## **WARNING!**

---

**Warning lights. When any one or more of the warning lights on the control console come "ON," immediately stop operation and shut down unit. Investigate and correct problem before proceeding with operation.**

---

# COMPONENT LOCATIONS

The following figure identifies the location of major machine components.

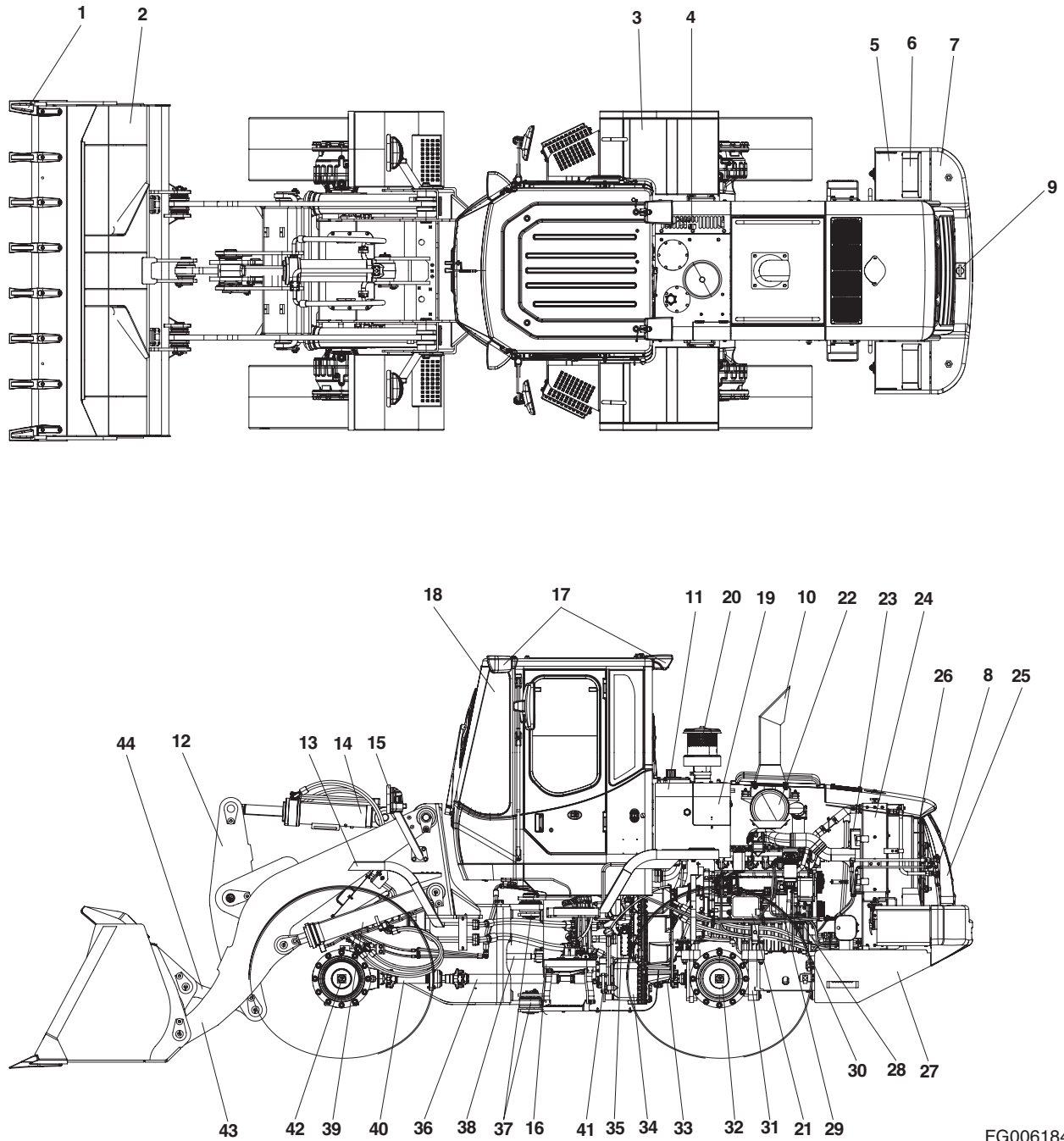

FG006184

Figure 1

Reference Number	Description
1	Bucket Teeth
2	Bucket
3	Rear Wheel Cover
4	Air Conditioner Condenser
5	Battery Box
6	Rear Light
7	Counterweight
8	Fan Motor
9	Towing Pin
10	Muffler Tail Pipe
11	Oil Tank
12	Tilt Lever
13	Front Wheel Cover
14	Bucket Cylinder
15	Headlight Support
16	Ladder
17	Work Light
18	Operator's Cabin
19	Air Cleaner
20	Engine Air Intake Precleaner
21	Engine
22	Muffler

Reference Number	Description
23	CAC Cooler
24	Radiator
25	Grille
26	Fan
27	Fuel Tank
28	Engine Oil Fill Cap
29	Engine Oil Filter
30	Engine Oil Level Dipstick
31	Rear Axle Pivot
32	Rear Axle
33	Drive Shaft (Rear)
34	Transmission
35	Transmission Oil Filter
36	Drive Shaft (Center)
37	Center Pin
38	Steering Wheel Cylinder
39	Boom Cylinder
40	Drive Shaft (Front)
41	Parking Brake
42	Front Axle
43	Loader Arm
44	Link

# OPERATOR'S AREA

Figure 2, identifies controls in operator's cabin.

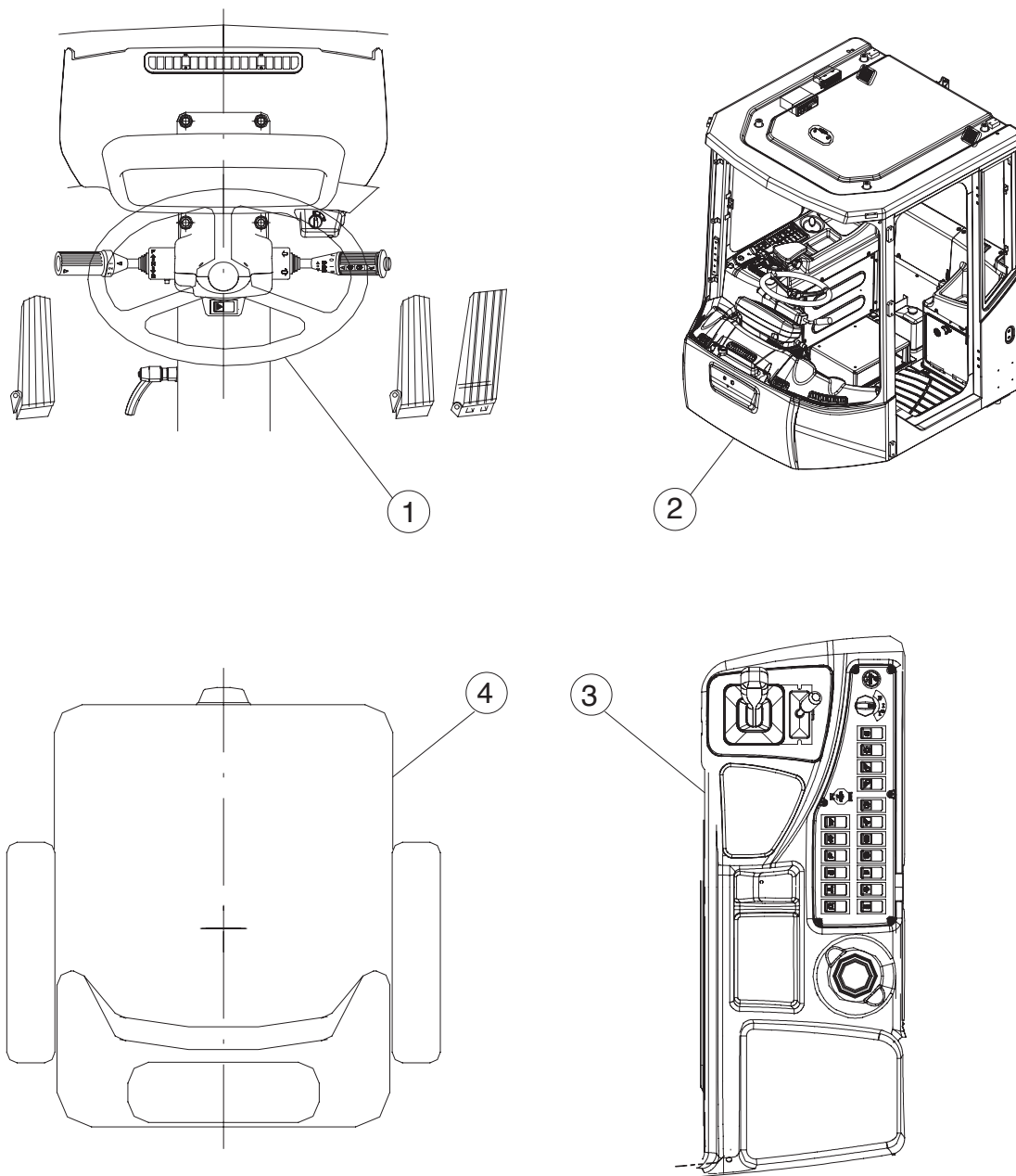

FG006189

**Figure 2**

Reference Number	Description
1	Steering Console and Pedal (See page 2-5)
2	Various Cabin Locations (See page 2-41)

Reference Number	Description
3	Right Side Switch Panel (See page 2-25)
4	Seat Adjustment (See page 2-52)

# STEERING CONSOLE AND PEDALS

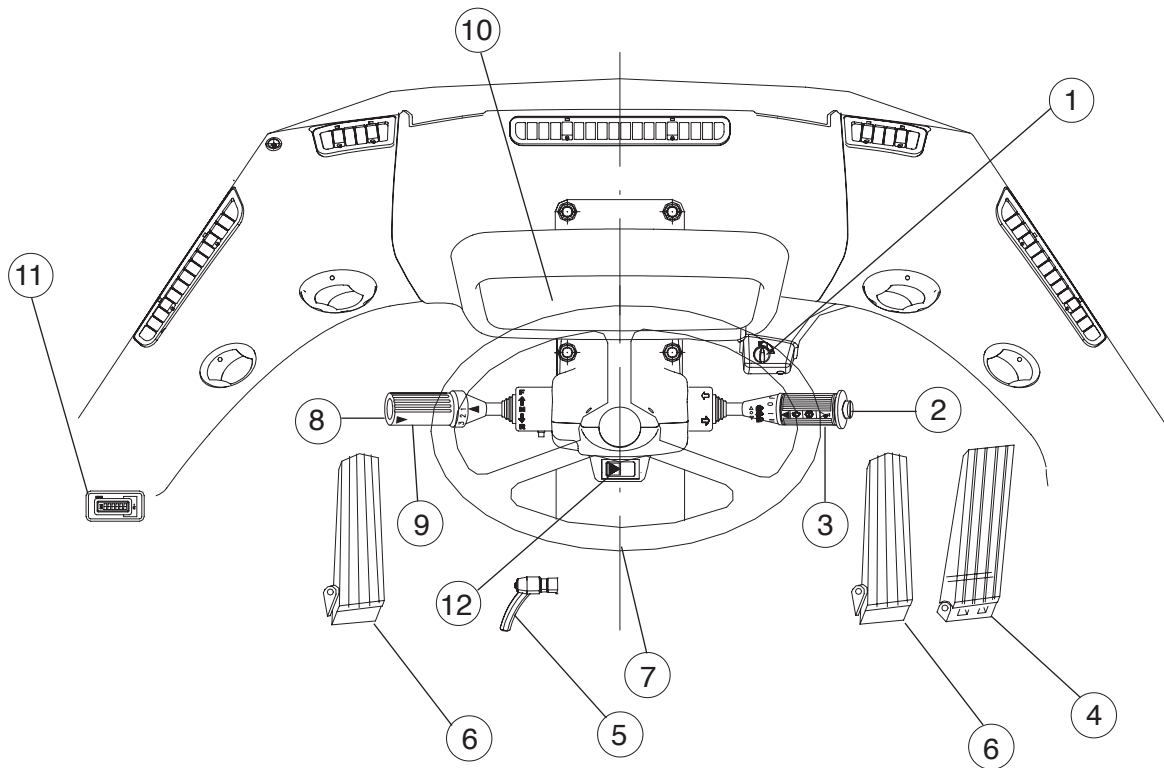

FG006191

Figure 3

Reference Number	Description
1	Starter Switch
2	Horn Button
3	Combination Switch
4	Accelerator Pedal
5	Steering Wheel Adjustment Lever
6	Brake Pedals

Reference Number	Description
7	Steering Wheel
8	Kick-down Switch
9	Transmission Lever
10	Front Instrument Panel (See page 2-14)
11	Hour Meter
12	Hazard Warning Light Switch

# 1. Starter Switch

A three-position starter switch is used to start or shut down engine for equipment operation.

- O. Turning the switch to this position turns the engine "OFF" along with its electrical system. In this position the engine is "OFF" but the interior cabin light and fuel tank transfer pump (if equipped) are functional.
- I. Turning the switch to this position turns the engine electrical system "ON." When the switch is first turned "ON" the six indicator/warning lights across the top of the instrument panel, will light for approximately two seconds. The battery warning light and the engine oil pressure warning light should remain "ON" after the other four have turned "OFF."

**NOTE:** *Preheat Indicator Light - The operation of the preheat cycle depends on coolant temperature. When the engine coolant is cold enough, the preheat indicator light will remain "ON" until the engine preheat cycle is completed. The preheat cycle takes about twenty seconds to complete, and the indicator light will turn "OFF." When the light turns "OFF," engage the starter.*

-  Moving switch to this position will crank engine. When engine starts, release key and allow it to return to the "I" (ON) position. Do not operate the starter switch for more than fifteen seconds at a time. This will help prevent damage to starter.

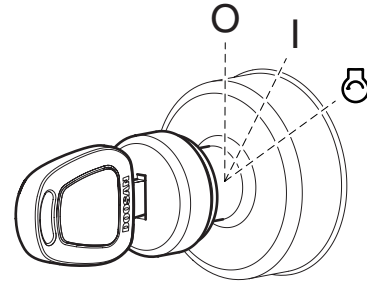

Figure 4

FG000014



## WARNING!

**DO NOT USE STARTING FLUIDS.** The preheat system could cause the starting fluid to explode. Starting fluids should never be used.

## 2. Horn Button (Two Places)

Pressing the button at the end of the combination switch (Figure 5) or the lowest button at the tip of the pilot control valve lever(joystick)(Figure 6) or the left (2-lever) / center (3-lever) button at the tip of the pilot control valve lever (finger tip, option) (Figure 7) the horn will sound.

**NOTE:** *Starter switch must be "ON."*

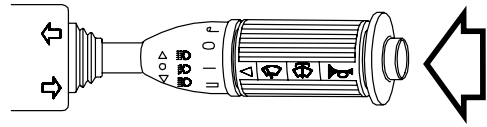

AHO0890L

**Figure 5**

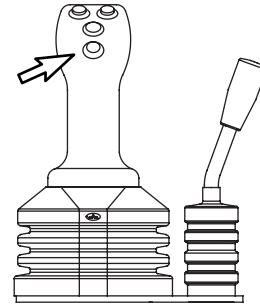

FG003941

**Figure 6**

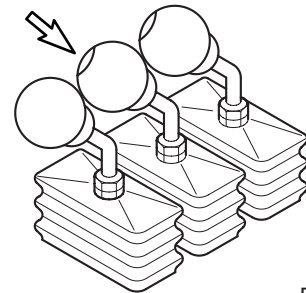

FG003935

**Figure 7**

### 3. Combination Switch

- A. Left Side Directional Switch - Pushing lever forward, activates left outside directional lights and directional indicator light on instrument panel.
- B. Right Side Directional Switch - Pulling lever back, activates right outside directional lights and directional indicator light on instrument panel.

**NOTE:** When turn is completed the lever automatically returns to the "NEUTRAL" position. Should it not, it can be manually returned by hand.

**NOTE:** Turn signals will function with starter switch in "OFF" position.

- C. Window Washer Switch - When the outside area of the lever is pressed, it activates the washer pump and sprays fluid on the windshield. (Only while being pressed.)

**NOTE:** Do not operate the windshield washer without any fluid. If operate without any fluid, the washer motor may be damaged. Check level in washer tank, and add fluid as required.

**NOTE:** Using soapy water or synthetic detergent instead of window cleaning fluid, may damage the wiper blade or painted surfaces. Use standard window cleaning fluid: SSK703

- D. Horn Button - The center button on end of lever activates horn. (Only while being pressed.)
- E. Wiper Switch - Activates wipers when outside area of lever is rotated.

J: Intermittent Mode - wipes every five seconds.

O: Stop (Off).

I: Normal Speed Mode.

II: High Speed Mode.

- F. Push Down - Locks into position and light turns "ON" the high beams.
- G. Neutral Position - Normal low beams.
- H. Pull Up - Momentarily turns "ON" both the low beams and high beams. (Returns to "NEUTRAL" position when released.)

**NOTE:** High and low beams will only function with the headlight switch in the "II" position.

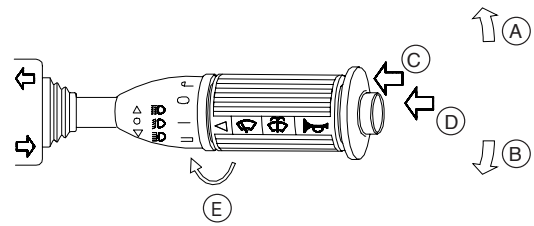

AHO0920L

Figure 8

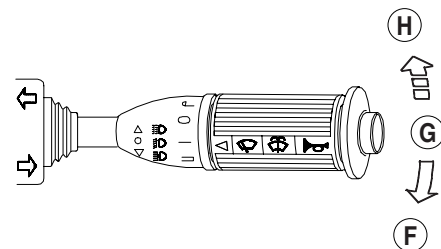

HAAA4350

Figure 9

## 4. Accelerator Pedal

Controls the travel speed of loader and working speed of load handling system.



### CAUTION!

The further the pedal is pressed, the more engine speed increases. However, do not press the pedal more than necessary; otherwise it will increase fuel consumption, cause short life on the engine, and in the worst case lead to a serious accident.

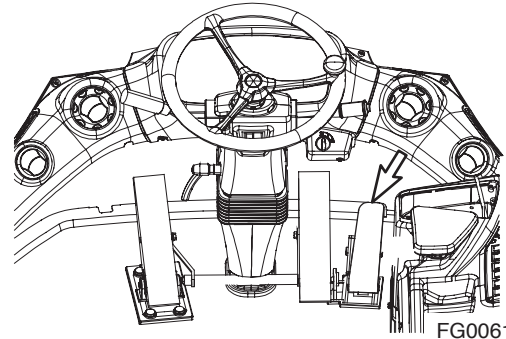

FG006192

Figure 10

## 5. Steering Wheel Adjustment Lever

Control lever (1, Figure 11) is used allow wheel to be moved to the most convenient position for the operator.

### Adjusting Steering Wheel Tilt

Pull lever (1, Figure 12) upward and move wheel (2, Figure 12) to desired position. Push lever down (Tilt angle is 21°).

### Adjusting Steering Wheel Telescopic

Pull lever (1, Figure 12) upward and move wheel (2, Figure 12) to desired position. Push lever down (telescopic stroke is 80 mm)

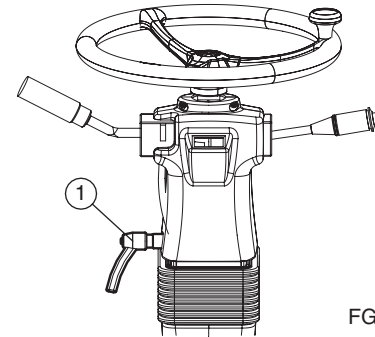

FG003887

Figure 11

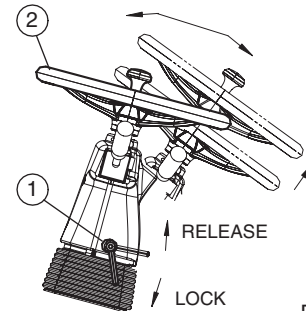

FG003888

Figure 12

## 6. Brake Pedal (Right and Left Pedals)

Pressing brake pedal will apply the brakes to the loader. The brake pedal modes can be switched from "INCHING" to "NO INCHING" or vice versa, by using the transmission cutoff switch (See page 2-34).



### CAUTION!

---

When descending down an incline, slow down the machine by using both the brake pedal and the engine as a brake by shifting the transmission to a lower gear. Using the brake pedal too often might lead to insufficient oil pressure, thus making it difficult to brake the loader.

---

### IMPORTANT

---

Do not use brake pedal as a foot rest. This will cause brake disk to wear faster than normal, and this could cause brake failure.

---

## 7. Steering Wheel

Rotating steering wheel controls position of front wheels and this determines direction of machine travel.

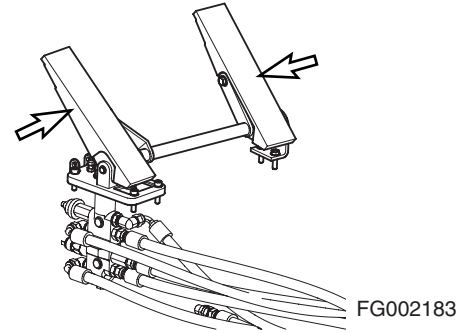

Figure 13

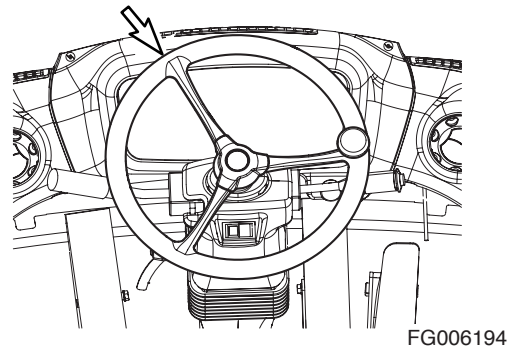

Figure 14

## 8. Kick-down Switch (Two places)

When transmission is in 2nd gear, pressing this switch will shift transmission into 1st gear. This will allow the driver to perform a quick digging movement.

**NOTE:** *Kick-down is "RELEASED" when transmission is placed in "NEUTRAL" position or the switch is pressed again.*

Kick-down function range:

- Automatic: 2nd, 3rd, 4th.
- Manual: 2nd.

A second kick-down switch (Figure 16) is on the reverse side button in the tip of the pilot control valve lever (joystick).

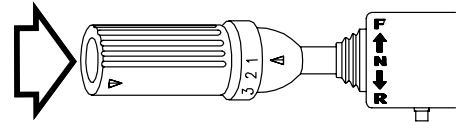

AHO0900L

Figure 15

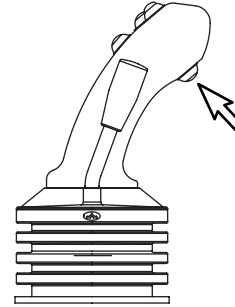

FG003936

Figure 16

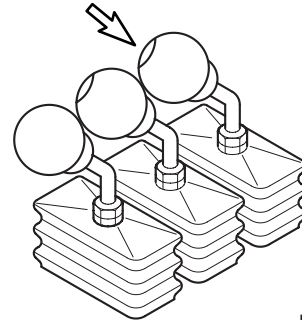

FG003940

Figure 17

## 9. Transmission Lever

- F Forward - When the lever is pushed forward, transmission is in "FORWARD." 1st, 2nd, 3rd and 4th are available.
- N Neutral - When the lever is returned to the center position, between forward and reverse, the transmission is in "NEUTRAL."
- R Reverse - When the lever is pulled back, transmission is in "REVERSE" 1st, 2nd and 3rd are available.

Rotating the switch shifts transmission between 1st, 2nd, 3rd or 4th gears.

**NOTE:** *There is a transmission display, on the dash, that indicates, gears, direction of travel, error codes and kick-down activation. (See page 2-15)*

A transmission neutral lever lock is in base of transmission lever. This neutral lever lock prevents the transmission lever from being moved out of "NEUTRAL."

- N "NEUTRAL LOCK" position. Prevents lever from being moved out of "NEUTRAL."
- D "DRIVE" position. Allows lever to be moved from "NEUTRAL" to "FORWARD and REVERSE."



### CAUTION!

"LOCK" transmission lever. Whenever machine is parked, "LOCK" transmission lever in "NEUTRAL" to prevent accidental machine movement.

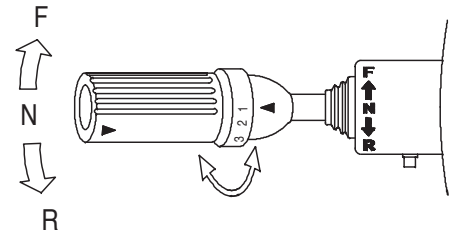

HAAA3680

Figure 18

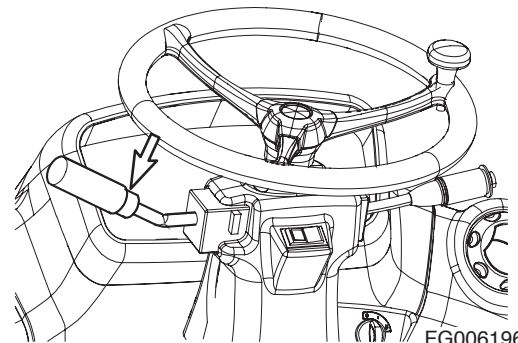

FG006196

Figure 19

## 10. Front Instrument Panel

See "Front Instrument Panel" on page 2-14.

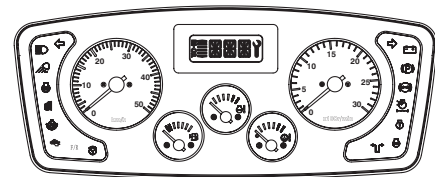

FG006053

Figure 20

## 11. Hour Meter

A LCD Meter that records total time. When engine is running, the hourglass icon blinks every four seconds. This shows that the hour meter is working.

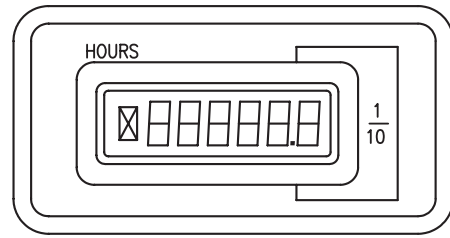

FG004112

Figure 21

## 12. Hazard Warning Light Switch

This warning light is used when the equipment is stopped due to a malfunction or when an emergency occurs. When this switch is pressed the directional indicator lights in front and back of the machine light up and flash, warning others in the area. At the same time the directional indicator lights on the instrument panel will turn "ON" to warn the operator. The hazard warning lights operate independent of the starter switch.

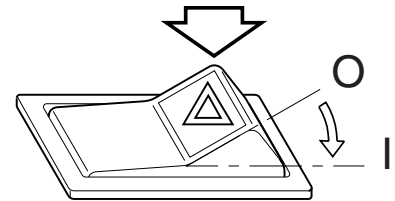

2665C

Figure 22

- O. In this position, this switch turns "OFF" hazard warning lights.
- I. In this position, this switch turns "ON" all turn signals and they flash simultaneously.

**NOTE:** *Hazard warning lights will function with starter switch in "OFF" position.*

# FRONT INSTRUMENT PANEL

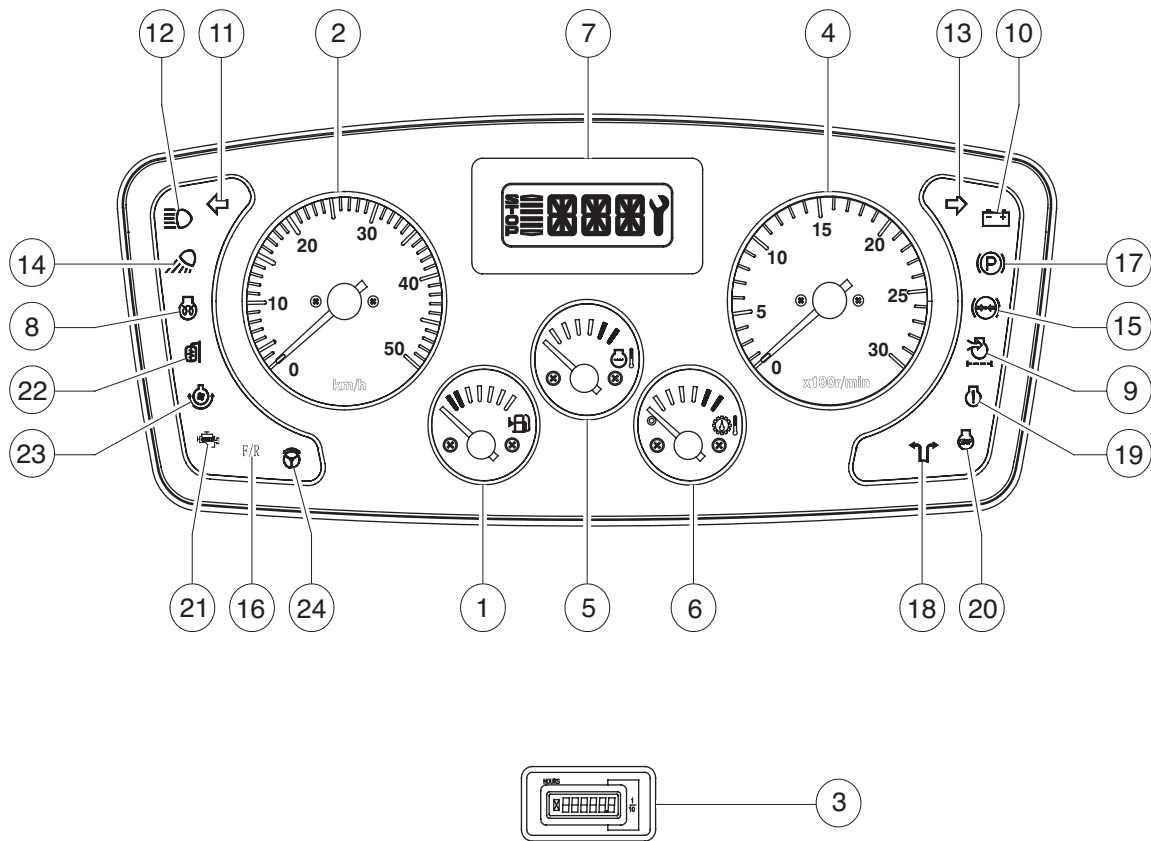

FG006054

Figure 23

## Gauges

Reference Number	Description
1	Fuel Gauge
2	Speedometer
3	Hour Meter
4	Tachometer

Reference Number	Description
5	Engine Coolant Temperature Gauge
6	Transmission Oil Temperature Gauge
7	Transmission Display

## Warning and Indicator Lights

Reference Number	Description
8	Preheat Indicator Light
9	Air Cleaner Clogged Warning Light
10	Battery Warning Light
11	Left Turn and Hazard Warning Light
12	High Beam Indicator Light
13	Right Turn and Hazard Warning Light
14	Work Light Indicator Light
15	Brake Fluid Pressure Warning Light

Reference Number	Description
16	F/R (Forward/Reverse) Selector Indicator Light
17	Parking Brake Indicator Light
18	Emergency Steering Indicator Light (Option)
19	Engine Warning Light
20	Not Used
21	Not Used
22	Mirror Heating Indicator Light
23	Reverse Fan Indicator Light
24	Electric Steering Select Indicator Light (Option)

---

## IMPORTANT

---

All of gauge and warning lights (except for the turn lights, high beam light, work light and transmission cutoff light) turn "ON" for two seconds with a warning buzzer sound when the starter switch is turned to the "I" (ON) position.

If any light fails to turn "ON" at this time, check the cause and replace.

---

## 1. Fuel Gauge

This gauge displays amount of fuel in tank. "F" means the tank is "full"; "E" means the tank is "empty." If the pointer comes close to the "E" (red zone), add fuel as soon as possible. When the pointer comes close to the "E" (red zone), approximately 21.2l (5.6 U.S. gal.) of fuel remains.

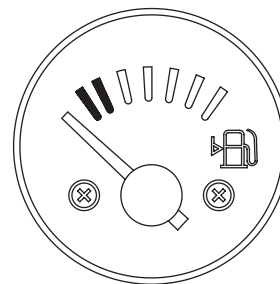

FG003948

Figure 24

## 2. Speedometer

This meter displays speed at which vehicle is traveling.

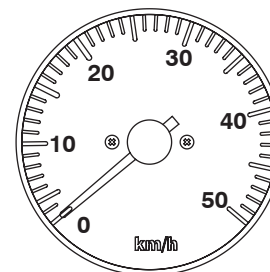

FG004182

Figure 25

## 3. Hour Meter

A LCD meter that records total time. When engine is running, the hourglass icon blinks every four seconds. This shows that the hour meter is working.

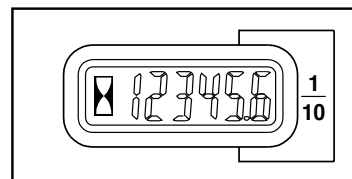

HA002012

Figure 26

## 4. Tachometer

This meter displays engine speed in revolutions per minute.

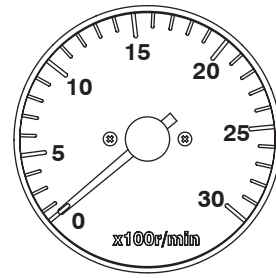

FG004183

Figure 27

## 5. Engine Coolant Temperature Gauge

This gauge displays temperature of engine coolant.



### CAUTION!

---

When the pointer indicates red zone, it means the engine is overheated. Stop the operation, let the engine run at low rpm and wait for it to cool down.

Do not shut down engine. If engine is shut down heat surge may occur.

---

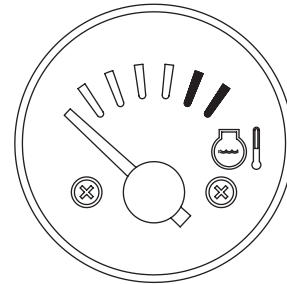

FG003949

Figure 28

## 6. Transmission Oil Temperature Gauge

This gauge displays temperature of oil in transmission converter and transmission circuit.



### CAUTION!

---

When the pointer indicates red zone, it means the transmission is overheated. Stop the operation, let the engine run at low rpm and wait for transmission to cool down.

---

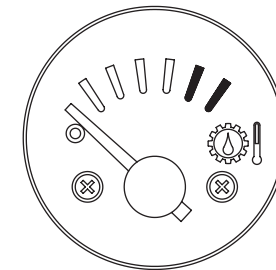

FG003950

Figure 29

## 7. Transmission Display

A transmission display is in the gauge panel on the dash. The LCD indicates, gears, direction of travel, error codes, and activated kick-down.

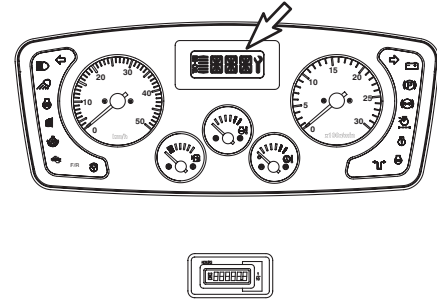

FG006119

Figure 30

Figure 31, shows the transmission display in detail.

A. Indicates travel direction and gear selection. See Figure 32 for more detailed information.

B. Indicates normal operation and error codes.

**NOTE:** Most codes are only two digits.

C. Indicates that error codes have occurred and are stored.

D. Indicates that operation must be stopped immediately to prevent damage to transmission and hazardous operating condition.

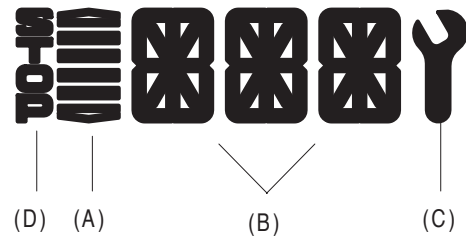
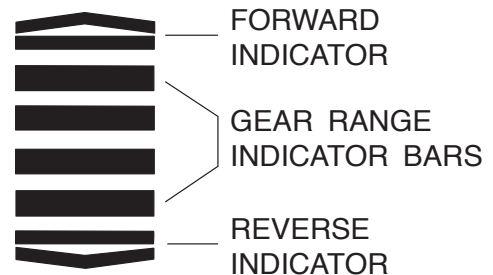

Figure 31

The gear range indicator bars will indicate which gear is selected by displaying the corresponding number of bars. The forward and reverse indicator bars will be "OFF" when the transmission is in "MANUAL MODE."

When transmission is in "AUTOMATIC MODE," all the gear range indicator bars and both travel direction indicators will be "ON."



HAAA3774

Figure 32

## 8. Preheat Indicator Light

This indicator light will turn "ON," when the engine preheat function is operating. Do not start engine as long as this light is "ON."

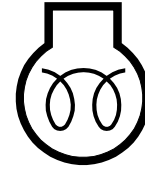

Figure 33

HAOA639L

## 9. Air Cleaner Clogged Warning Light

This warning light will turn "ON," when dirt has built up in the air filter and is beginning to restrict flow of air. Clean or replace air filter before continuing to operate machine. To turn indicator light "OFF," turn starter switch "OFF" and then back "ON."

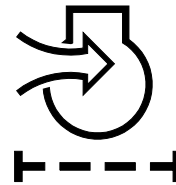

Figure 34

HAOA660L

## 10. Battery Warning Light

When starter switch is first turned to "ON" position, this red warning light should turn "ON." When engine is running this red light should turn "OFF." If light remains "ON" when engine is running, alternator is defective.

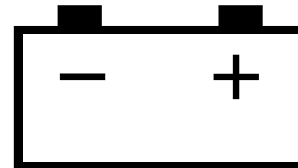

Figure 35

HAOA610L

## 11. Left Turn and Hazard Warning Light

This light blinks when left turn signal is turned "ON."  
Both lights blink when warning lights are turned "ON."

**NOTE:** *If left and right turn indicators blink together, or if they blink faster than normal, a light bulb is not operating or flasher solenoid is damaged.*



FG004173

Figure 36

## 12. High Beam Indicator Light

This indicator light will turn "ON," when the headlights are turned to "HIGH BEAM."

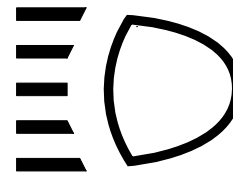

HAOD394L

Figure 37

## 13. Right Turn and Hazard Warning Light

This light blinks when right turn signal is turned "ON."  
Both lights blink when warning lights are turned "ON."

**NOTE:** *If left and right turn indicators blink together, or if they blink faster than normal, a light bulb is not operating or flasher solenoid is damaged.*

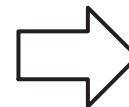

FG004174

Figure 38

## 14. Work Light Indicator Light

This indicator light will turn "ON," when the front and/or rear work lights are activated.



Figure 39

2658A

## 15. Brake Fluid Pressure Warning Light

This warning light will turn "ON," when pressure drops in brake fluid circuit. When light turns "ON," an alarm also sounds.



**WARNING!**

---

Never operate or travel machine when this light is "ON" or when alarm is sounding. Always investigate cause of the drop in brake fluid pressure, and repair problem before operating or traveling machine.

---

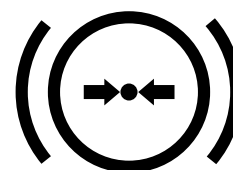

Figure 40

HA002024

## 16. F/R (Forward/Reverse) Selector Indicator Light (Option)

This indicator light will turn "ON," when the 2nd gear function is selected.

**NOTE:** See "F/R (Forward/Reverse) Travel Control System (Option)" on page 3-16 for further information.

F/R

Figure 41

BSO0510L

## 17. Parking Brake Indicator Light

This indicator light will turn "ON," when the parking brake is "APPLIED." If vehicle is moved while parking brake is applied, a warning alarm will sound.



### **WARNING!**

---

If vehicle is moved while this light is turned "ON," it could cause premature wear or damage the brake.

Always "RELEASE" parking brake and make sure this light is "OFF" before traveling machine.

---



Figure 42

0717A

## 18. Emergency Steering Indicator Light (Option)

This indicator light will turn "ON," when the emergency steering system is activated due to a hydraulic failure. Immediately stop any operation, stop machine, "APPLY" parking brake, and shut down engine.



### **DANGER!**

---

Emergency steering indicator light. If this light turns "ON" while operating machine, discontinue operation immediately. This light indicates that there is a serve problem with the unit.

---

**NOTE:** *The light will also turn "ON" when the system is being tested.*



Figure 43

AJO0450L

## 19. Engine Warning Light

If a defect is present in the engine system, and it is recognized by the ECU and cause a malfunction in operation, it can be displayed with the engine warning light to indicate a warning to the operator. If this Light turns "ON" or "blinking," check the engine as described under the engine diagnostic switch (See page 2-35).

- Light turned "ON": nonfatal system error
- Light is "BLINKING": fatal system error

**NOTE:** *The engine warning light flashes out the two digit fault code in the diagnostic mode.*

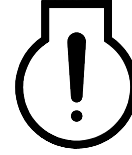

AQ00040L

Figure 44

### Fault Code 35 (example)



○: Long Light    ○: Short Light

FG004339

Figure 45

## 20. Not Used

## 21. Not Used

## 22. Mirror Heating Indicator Light

This indicator light will turn "ON," when the mirror heater is operated.



FG004184

Figure 46

## 23. Reverse Fan Indicator Light

This indicator light will turn "ON," when the cooling fan rotates in the reverse direction.

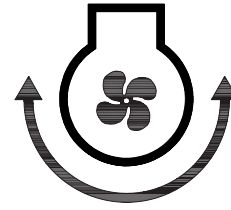

FG004185

Figure 47

## 24. Electric Steering Select Indicator Light(Optional)

This indicator light will turn "ON," when the electric steering system is selected.



FG004186

Figure 48

# RIGHT SIDE SWITCH PANEL

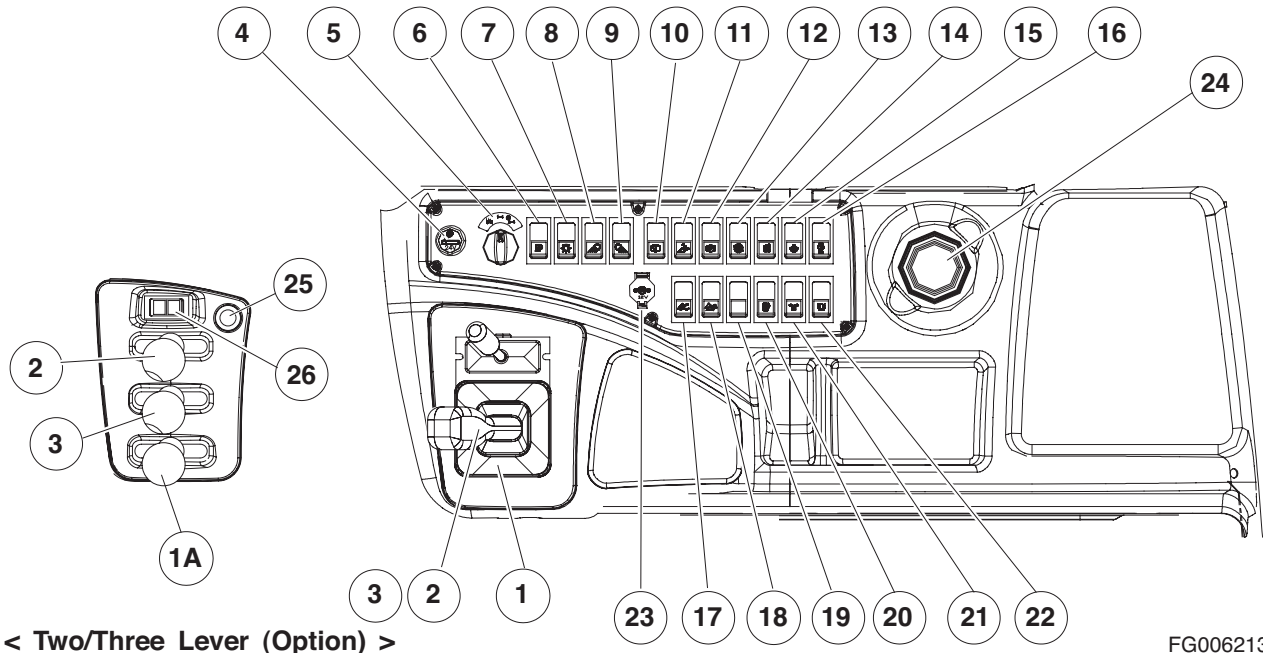

< Two/Three Lever (Option) >

FG006213

Figure 49

Reference Number	Description
1	Pilot Control Valve Lever (Joystick)
1A	Pilot Control Valve Lever (Two/Three Lever) (Option)
2	Kick-down Switch
3	Horn Button
4	Cigar Lighter
5	Automatic Shift Mode Switch
6	Economic Mode Switch
7	Headlight Switch
8	Front Work Light Switch
9	Rear Work Light Switch
10	Rear Wiper Switch
11	Pilot Cutoff Switch
12	Parking Brake Switch
13	Transmission Cutoff Switch
14	Mirror Heating Switch

Reference Number	Description
15	Reverse Fan Switch
16	Engine Diagnostic Switch
17	Boom Float Switch (Option)
18	LIS Switch (Option)
19	Not Used
20	Fuel Heater Switch (Option)
21	Emergency Steering Test Switch (Option)
22	Rotating Beacon Light Switch (Option)
23	Power Socket for 12 Volt
24	Cup Holder
25	F/R (Forward/Reverse) Selector Switch (Option)
26	F/R (Forward/Reverse) Control Switch (Option)

# 1. Pilot Control Valve Lever (Joystick)

If loader is equipped with log forks this lever controls boom, bucket and log forks.

Used to position bucket and boom. This lever is capable of raising or lowering boom, and crowding or dumping bucket. When machine is being traveled, the lever (joystick) can be "LOCKED" out, to prevent any movement of bucket or boom. To "LOCK" out lever (joystick), place pilot cutoff switch in "LOCKED" position.

Pilot control valve lever (joystick) operating pattern and description of operation.

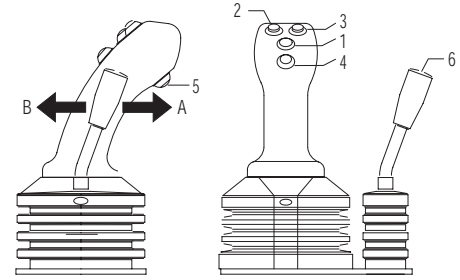

BS00530L

Figure 50

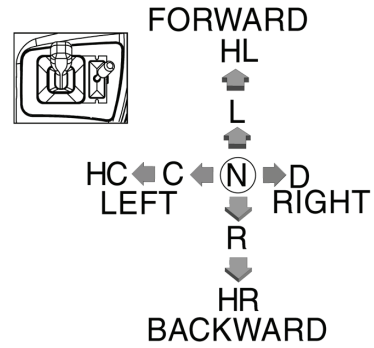

FG007019

Figure 51

- HL.** Hold lever in Lower Mode
- L.** Lower
- HC.** Hold lever in Bucket Crowd
- C.** Bucket Crowd
- N.** Neutral
- D.** Bucket Dump
- R.** Raise
- HR.** Hold lever in Raise Mode

- A. When the log forks control lever (6, Figure 50) is pushed forward the log forks are allowed to open.
- B. When the log forks control lever (6, Figure 50) is pulled back the log forks are allowed to close.

This lever is capable of forward travel and reverse travel (2nd gear function).

## 1. Neutral Switch

When this switch is pressed, 2nd gear function will be operated, and then 2nd gear indicator light turns "ON."

When 2nd gear function is operated, this switch is pressed, and then machine is neutral

## 2. Forward Switch

When this switch is pressed at forward traveling while "KD" (5, Figure 50) switch is pressed, machine can travel forward. When machine is travelled, it can convert forward and reverse travel without pressing "KD" (5, Figure 50) switch.

## 3. Reverse Switch

When this switch is pressed at reverse traveling while "KD" (5, Figure 50) switch is pressed, machine can travel reverse. When machine is travelled, it can convert forward and reverse travel without pressing "KD" (5, Figure 50) switch.

## 4. Horn Switch

(See page 2-29)

## 5. Kick-down Switch

(See page 2-28)

**NOTE:** *Operating condition of 2nd gear function.*

- Start a engine.
- Transmission lever is neutral.
- Parking brake switch is off (release).

**NOTE:** *Release condition of 2nd gear function.*

- When the transmission lever will be push forward or pull reverse.
- When the parking brake switch turns "ON."
- When the starter switch turns "OFF."

## 1A. Pilot Control Valve Lever (Two/Three Lever) (Option)

Move left control lever forward (2, Figure 52) to dump bucket, or rearward (4, Figure 52) to roll back bucket.

Move right control lever forward (3, Figure 52) to lower boom or rearward (5, Figure 52) to raise boom.

Float (right lever in full forward detent position (1, Figure 52)): This position allows oil flow in and out both ends of cylinders so the bucket can follow the contour of the ground. Manually release lever from the position.

Return-to-Dig (left lever in full rearward detent position (6, Figure 52)): Bucket will return to set dig position.

Boom Height Kick-out right lever in full rearward detent position (7, Figure 52): Lever will remain in this position until boom is at a preset height, then will return to neutral automatically.

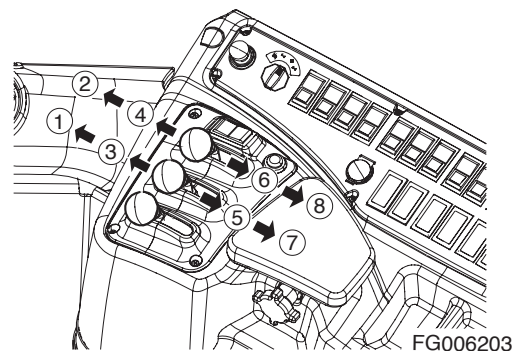
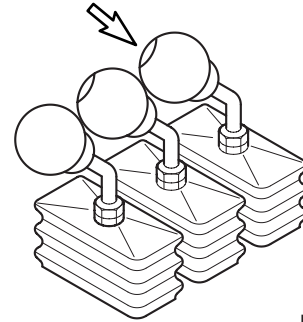

Figure 52

1. BOOM FLOAT
2. BUCKET DUMP
3. BOOM LOWER
4. BUCKET CROWD
5. BOOM RAISE
6. BUCKET RETURN TO DIG
7. BOOM HEIGHT KICK-OUT

A. Kick-down Switch (Two Places)

(See page 2-11)



FG003940

Figure 53

B. Horn Switch (Two Places) / Log Fork Switch (Option)

- Horn switch function.
- Log fork switch function.

When the log forks control lever is pushed forward or pulled back while this switch is pressed, the log forks are allowed to open or closed. (See page 2-26)

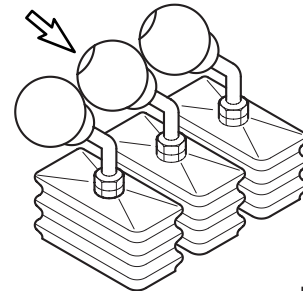

FG003935

Figure 54

## 2. Kick-down Switch (TWO PLACES)

Kick-down Switch Function - When transmission is in 2nd gear, pressing this switch (Figure 56) will shift transmission into 1st gear. This will allow the driver to perform a quick digging movement.

Kick-down function range:

- Automatic: 2nd, 3rd, 4th.
- Manual: 2nd.

**NOTE:** Kick-down is "RELEASED" when transmission is placed in "NEUTRAL" position or the switch is pressed again.

A second kick-down switch (Figure 55) is on the end of the transmission lever.

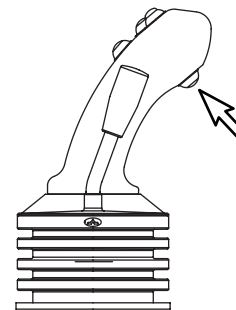

FG003936

Figure 55

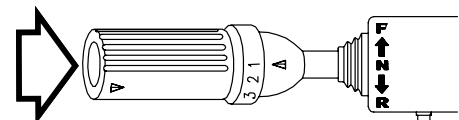

AHO0900L

Figure 56

### 3. Horn Button (Two Places)

Pressing the lowest button at the tip of the left pilot control valve lever (joystick) (Figure 57) or the button at the end of the combination switch (Figure 58) will sound the horn.

**NOTE:** *Starter switch must be "ON."*

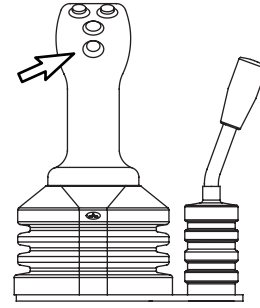

FG003941

Figure 57

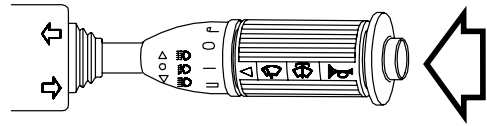

AHO0890L

Figure 58

### 4. Cigar Lighter

Push the lighter all the way into the socket and release your hand. After pushing it in, it will be ejected when it is heated. If it does not eject after a short time, pull it out and have it serviced.

---

## IMPORTANT

---

**The cigar lighter is powered by a 24 volt circuit.  
Never plug any 12 volt device into the cigar lighter.**

---

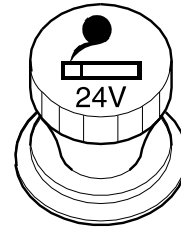

HAOA780L

Figure 59

## 5. Automatic Shift Mode Switch

- Auto 1-4 mode (Working mode)
  - 1) Turn the gear selector control to gear position 4
  - 2) Set the shift mode selector to "Auto 1-4"
  - 3) Selector the directional gear and accelerate the machine.
  - 4) Up and downshifts are made automatically between 1st - 2nd - 3rd - 4th gears forward and between 2nd - 3rd in reverse.
  - 5) It is unnecessary to use kick-down function for 1st gear.
- Auto 2-4 mode (Travel mode)
  - 1) 1-3 is same as Auto 1-4
  - 2) Up and downshifts are made automatically between 2nd - 3rd - 4th gears forward and between 2nd - 3rd in reverse.
  - 3) Kick-down switch must be used for shifting to 1st gear.
- Manual mode  
After starting gear shifting is done manually.

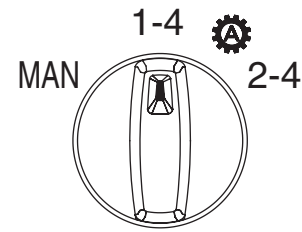

FG004181

Figure 60

## 6. Economic Mode Switch

This economic mode switch allows the operator to switch between 100% throttle torque and droop curve and about an 80% derated torque curve and droop. In the economy mode, fuel consumption is clearly reduced by utilising a reduced-power characteristic map for the engine. This is of benefit with all general loading work.

- O. In this position torque switch is set to the "off" position, and 100% torque is permitted for hard digging or driving up steep inclines.
- I. In this position torque switch is turn "ON", which limits engine torque to 80% of maximum.

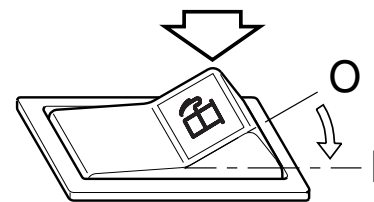

FG004998

Figure 61

## 7. Headlight Switch

- O. In this position, this switch turns "OFF" clearance, tail, instrument panel, switch and headlights.

**NOTE:** *If the switch is not in this position with the engine not running, the pilot buzzer will sound to warn the operator that the batteries are being discharged.*

- I. In this position, this switch turns "ON" clearance, tail, instrument panel and switch lights.
- II. In this position, this switch turns "ON" clearance, tail, instrument panel, and headlights.

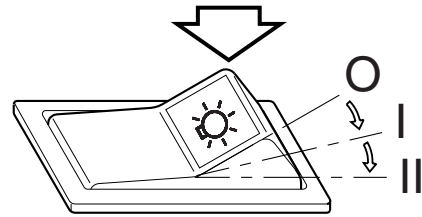

FG003976

Figure 62



### CAUTION!

Do not leave clearance, tail, instrument panel or headlights "ON" when the engine is not running. Leaving lights "ON" with the engine shut down will discharge batteries.

## 8. Front Work Light Switch

- O. In this position, this switch turns "OFF" work lights mounted on the front top of cabin.
- I. In this position, this switch turns "ON" work lights mounted on the front top of cabin.



### CAUTION!

Do not turn "ON" the work light when traveling on public roads.

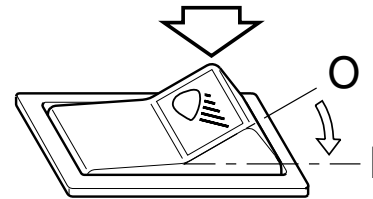

HAOQ071L

Figure 63

## 9. Rear Work Light Switch

- O. In this position, this switch turns "OFF" work lights mounted on the rear top of cabin and the sides of radiator.
- I. In this position, this switch turns "ON" work lights mounted on the sides of radiator.
- II. In this position, this switch turns "ON" work lights mounted on the rear top of cabin and the top of the sides of radiator.

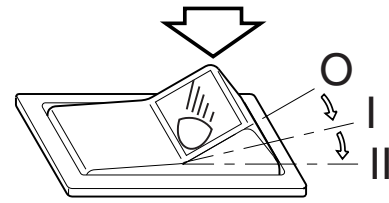

AHO0850L

Figure 64



### CAUTION!

Do not turn "ON" the work light when traveling on public roads.

## 10. Rear Wiper Switch

- O. In this position, this switch turns "OFF" windshield wiper mounted on rear windshield of operator's cabin.
- I. In this position, windshield washer fluid sprays onto the rear windshield while running the rear wiper. When released, the switch returns to the "O" (OFF) position.
- II. In this position, this switch turns "ON" windshield wiper mounted on rear windshield of operator's cabin.

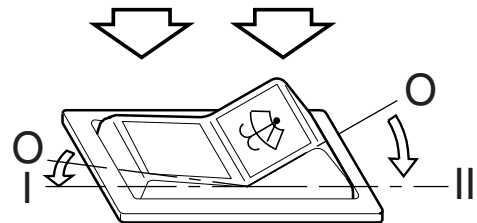

HAOD421L

Figure 65



### CAUTION!

The washer pump can be damaged if it is activated while there is no fluid in the tank.

The fluid level must be checked regularly and refilled as necessary.

Using soap or other solvents instead of the recommended washer may damage the wiper blades and the paint finish. Only use the recommended washer fluid or equivalent.

## 11. Pilot Cutoff Switch

- O. In this position the operator cannot operate the pilot control valve lever (joystick).
- I. In this position the operator can fully control the movement of the pilot control valve lever (joystick).



### CAUTION!

---

When driving or parking, the pilot cutoff switch must be changed to "O" (OFF) position.

---

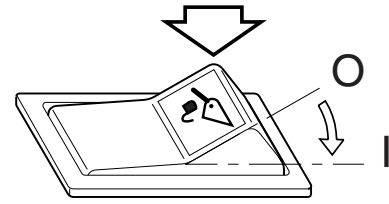

Figure 66

HBO1110L

## 12. Parking Brake switch

- O. In this position, the parking brake is "RELEASED" and the indicator light on the front instrument panel turns "OFF."
- I. In this position, the parking brake is "APPLIED" and the indicator light on the front instrument panel comes "ON." This brake can also be used as an emergency brake.



### WARNING!

---

Set the parking brake switch in the "I" (APPLIED) position before leaving the loader. Make sure to "APPLY" the parking brake switch before trying to start the loader.

---



### CAUTION!

---

Do not use the parking brake to stop the loader, except in an emergency; otherwise, it might cause premature wear or damage of the brake.

---

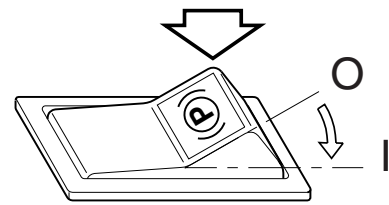

Figure 67

HA002019

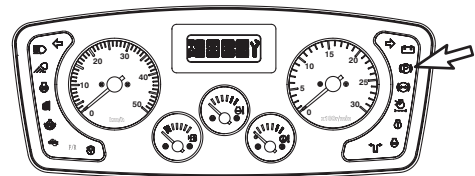

Figure 68

FG006055

### 13. Transmission Cutoff Switch

This switch changes the mode of the brake pedal from "INCHING" to "NO INCHING."

- O. In this position, the "NO INCHING" mode is selected.

In the "NO INCHING" mode, the power transmission line is still connected when the brake pedal is pressed, thus, making it easier to start off on an incline. This mode is also suitable for traveling, because both dynamic engine braking and the service brake can be used when descending grades.

- I. In this position, the "INCHING" mode is selected.

In this mode, the transmission is put in "NEUTRAL" by pressing the left brake pedal. This mode is suitable for a load handling operation. When the accelerator pedal is pressed in this setting, more power is concentrated on the load handling system, to quicken the boom lifting speed.

**NOTE:** 1) Transmission "CUTOFF" function dose not operate at 3rd and 4th gear for protection of transmission.

2) Despite transmission "CUTOFF" switch, the right brake pedal has braking function only.

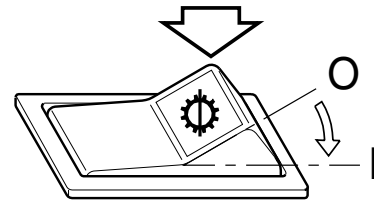

HA3O2018

Figure 69



### WARNING!

---

When pressing brake pedal while traveling or working on a slope, set this switch to "O" for dynamic engine braking.

---

### 14. Mirror Heating Switch

This switch is used to operate a heater installed in the mirror. Press the switch and the mirror heater will remove frost and ice from mirror.

- O. "OFF" position.
- I. "ON" position.

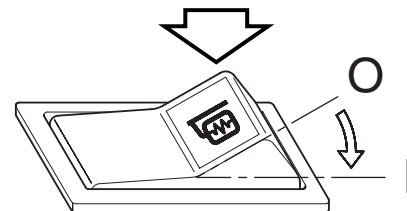

FG004187

Figure 70

## 15. Reverse Fan Switch

This switch causes the radiator cooling fan to rotate in the reverse direction. The function of reversing the direction of the radiator cooling fan is effective in cleaning the radiator.

- O. "OFF" position.
- I. "ON" position.

Activate the switch for reverse rotation in the following order;

- A. Turn the starter switch "O" (OFF) → "I" (ON) and then turn the of the cooling fan reverse rotation switch "O" (OFF) → "I" (ON) and start the engine.
- B. For reverse operation, the cooling fan reverse rotation indicator light turns "ON" the same time.
- C. To return to forward rotation, shut down engine, change the position of the reverse switch "ON" → "OFF," and start the engine again.

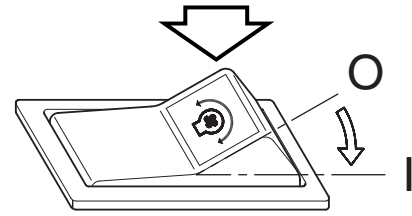

FG004188

Figure 71



### WARNING!

**Never travel or work in the reverse fan rotation mode. This may cause damage to the cooling system. Make sure that this switch is in the "O" (OFF) position before starting the engine and operating the machine.**

## 16. Engine Diagnostic Switch

If the engine warning light turns "ON" or "blinks," when the engine is running, it means a fault code has been recorded. When this occurs, the engine diagnostic switch allows the operator to view the fault codes. The active fault code is started after this switch turns "ON" "OFF," if during the output of the fault code this switch turns "ON" "OFF" again, the output of the current fault code is interrupted and the next fault code is displayed. Each depression of the diagnostic switch causes the output of a fault code. If a fault code is displayed, contact your authorized dealer for repair. To know the fault code information, refer to the engine control system of shop manual.

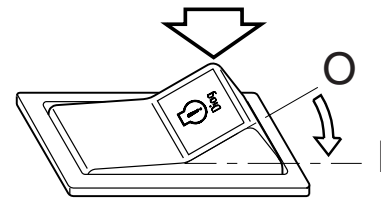

AQO0120L

Figure 72

## 17. Boom Float Switch (Option)

Boom float allows the bucket to follow the contour of the ground/working surface. When pressing this switch and setting work lever to float position, the lever is locked (detent) and boom is lowered. When boom is matched to setting position, the lever lock is released, and lever is returned to "NEUTRAL" position. Boom lowering is stopped.

- O. In this position, this switch turns "OFF" boom float.
- I. In this position, this switch turns "ON" boom float.

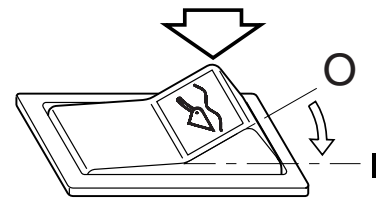

HAOA751L

Figure 73

## 18. Load Isolation System (LIS) Switch (Option)

This switch enables the boom cylinder to absorb shock loading of the machine during traveling and working. It improves dynamic stability, machine life, and comfortability. It is most effective when traveling with load in the bucket.

- O. In this position, the LIS turned "OFF."
- I. In this position, the LIS turned "ON" at all travel speeds.
- II. In this position, the LIS will "AUTOMATICALLY TURN ON" if the forward travel speed exceed 6 km/h (3.7 MPH) or reverse travel speed exceed 4 km/h (2.5 MPH). LIS will automatically turn "OFF" if the forward speed is less than 4 km/h (2.5 MPH) or if reverse travel speed is less than 2 km/h (1.2 MPH).

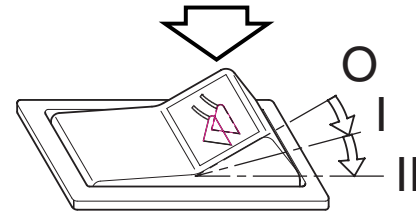

FG004256

Figure 74

## 19. Not Used

## 20. Fuel Heater Switch (Option)

This switch is used to operate the fuel heater. When the switch is pressed, the fuel heater starts to heat fuel. If the fuel temperature is 5°C and higher, the fuel heater does not operate, even if switch in "I" (ON) position

- O. In this position, this switch turns "OFF" fuel heater.
- I. In this position, this switch turns "ON" fuel heater.

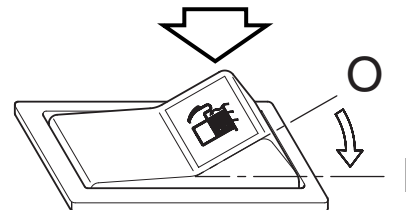

FG004190

Figure 75

## 21. Emergency Steering Test Switch and Automatic Test (Option)

### Emergency Steering Test Switch

This switch is used to test whether the emergency steering system is properly functioning.

The system must be tested during the start-up procedure to ensure that the system is properly functioning.

Test emergency steering system using the following procedure:

- A. Turn starter switch to "I" (ON) position.

**NOTE:** *Do not start engine.*

- B. Press emergency steering test switch and turn steering wheel at the same time. If system is functioning properly the unit should steer. The emergency steering indicator light should turn "ON."

**NOTE:** *If unit does not steer, do not operate unit until problem is corrected.*

- C. Release switch. Switch will automatically return to "O" (OFF) position.

### Automatic Test

This is a system check that tests the hydraulic oil pressure in the emergency steering system lines. With starter switch turn to "I" (ON) position, an emergency warning light on the front gauge panel will turn "ON" for about three seconds.

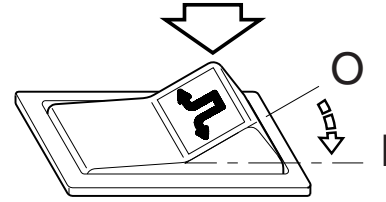

Figure 76

AJO0010L



## WARNING!

---

**Do not press this switch continuously. Continuously pressing switch will cause heavy battery discharge. The emergency steering DC motor has a high consumption of power.**

---

## 22. Rotating Beacon Light Switch (Option)

- O. In this position, this switch turns "OFF" rotating beacon light.
- I. In this position, this switch turns "ON" rotating beacon light.

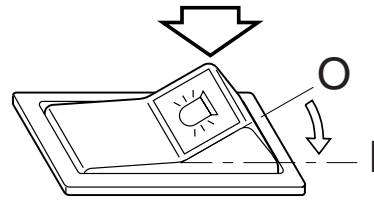

Figure 77

HAOA750L

## 23. Power Socket for 12 Volt

This is a power socket for only 12V DC devices.

This socket can be used for charging a cellular phone or powering a small 12V DC electrical device.

Open the cap when using it.

**NOTE:** *This socket is designed for small electrical capacity devices. Do not use this socket for large electrical capacity devices. Thus, damage can be avoided.*

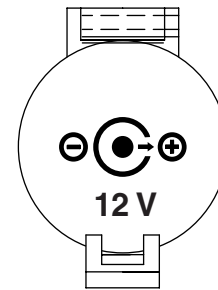

Figure 78

HAAE1990

## 24. Cup Holder

Place to put beverages.

## 25. F/R (Forward/Reverse) Selector Switch (Option)

- O. In this position, the F/R control switch is "OFF"
- I. In this position, the F/R control switch is activated. When released the switch returns to the "O" (OFF) position, but the system is still activated. When this switch is depressed again, F/R control switch is "OFF"

**NOTE:** *1) When activating system, the transmission lever and F/R control switch must be in "NEUTRAL."*

*2) If the transmission lever is actuated (moved), the gearshift functions of the F/R control switch are deactivated, and forward/reverse travel is again controlled by the transmission lever.*

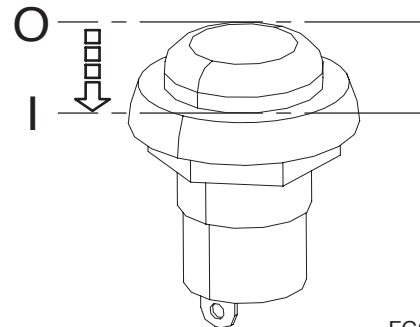

Figure 79

FG008125

## 26. F/R (Forward/Reverse) Control Switch (Option)

To be able to use the forward/reverse function, the F/R selector switch must first be depressed. When the switch is activated, the F/R selector indicator light will be turned "ON" in the instrument panel.

- O. In this position, the machine is in "NEUTRAL"
- I. In this position, the machine travels "FORWARD"
- II. In this position, the machine travels "REVERSE"

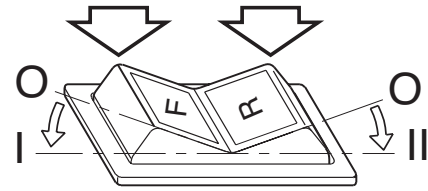
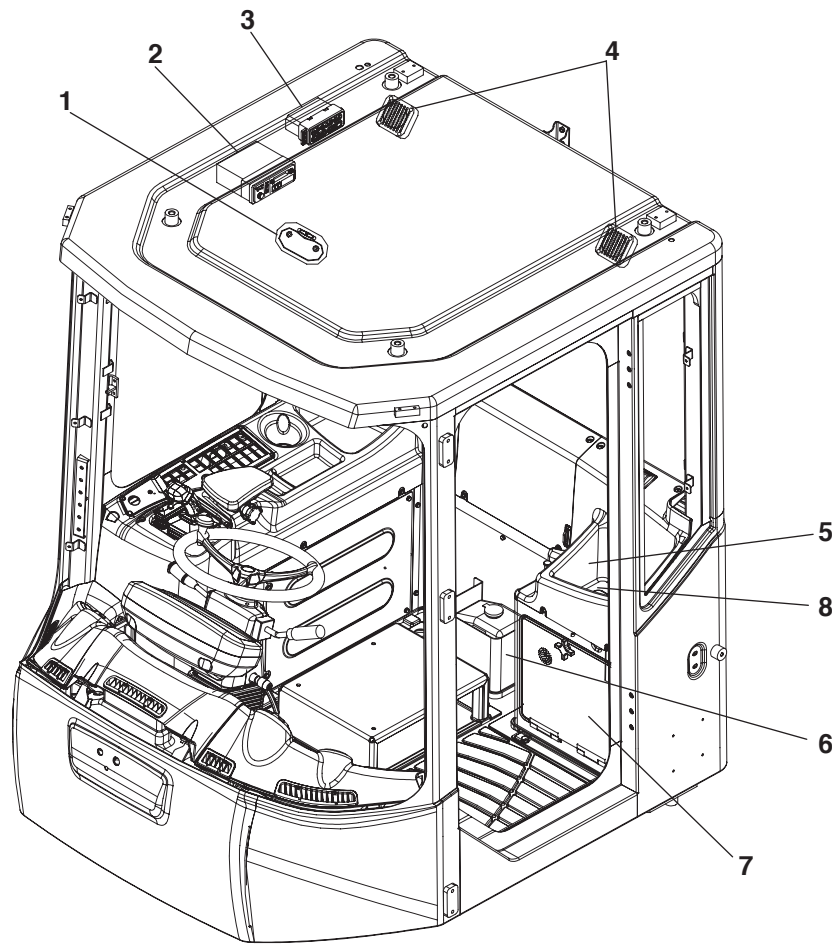

Figure 80

BSO0410L

**NOTE:** *If the transmission lever is moved out of "NEUTRAL" while operating the F/R control switch, the transmission lever will override the switch. The F/R control switch system will require, that the F/R selector switch to be pressed again, with the transmission lever in "NEUTRAL."*

# VARIOUS CABIN LOCATIONS



FG006505

Figure 81

Reference Number	Description
1	Cabin Light
2	Stereo / CD Player (Option)
3	Heater and Air Conditioner Control Panel
4	Speakers

Reference Number	Description
5	Storage Compartment
6	Windshield Washer Tank
7	Electrical Box
8	Fuse Box

## 1. Cabin Light

Located in the middle of front cabin, it illuminates the cabin for night work. Light turns on when the switch is in the "ON" or "O" position but off in the "OFF" position. Cabin light may be turned "ON" and "OFF" irrespective of the position of the starter switch.

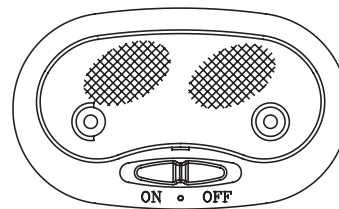

FG004192

Figure 82

## 2. Stereo / CD Player (Option)

For operation of stereo see "Stereo / CD Player (Optional)" on page 2-50.

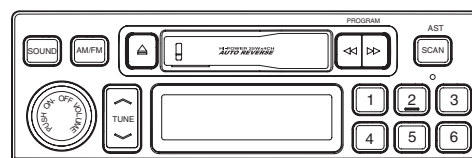

FG004057

Figure 83

## 3. Heater and Air Conditioner Control Panel

For operation of heater and air conditioner see "Heater and Air Conditioner Operation" on page 2-45.

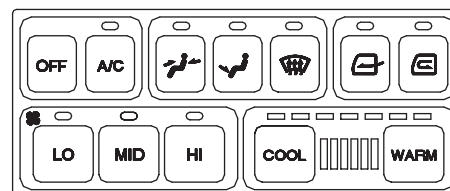

FG003955

Figure 84

## 4. Speakers

Emits sound generated by stereo.

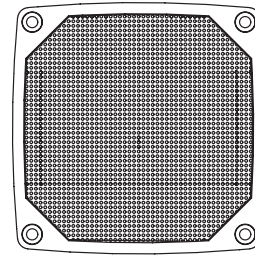

Figure 85

HBOM350L

## 5. Storage Compartments

There are two storage compartments (1 and 2, Figure 86) located both sides behind of the operator's seat. Keep the operation manual and other documents in this compartment.

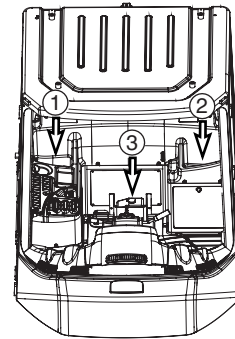

Figure 86

FG003889

## 6. Windshield Washer Tank

Contains windshield washer fluid. It is located behind the operator's seat. (3, Figure 86)

## 7. Electrical Box

Contains relays and electric components. It is located on left side of cabin.

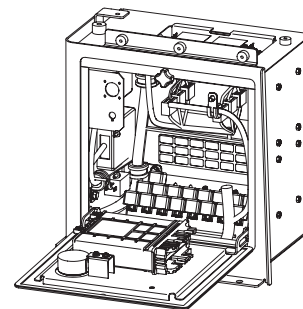
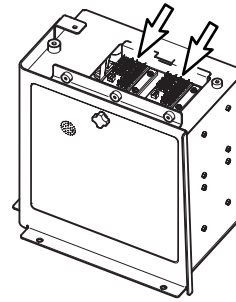

Figure 87

FG003956

## 8. Fuse Box

The fuse box is on the upper side of electric box. For a detailed explanation of fuses see “Fuse Box/Relay/Engine Emergency Stop Switch” on page 2-57.



FG003959

**Figure 88**

# HEATER AND AIR CONDITIONER OPERATION

## Location of Controls and Vents

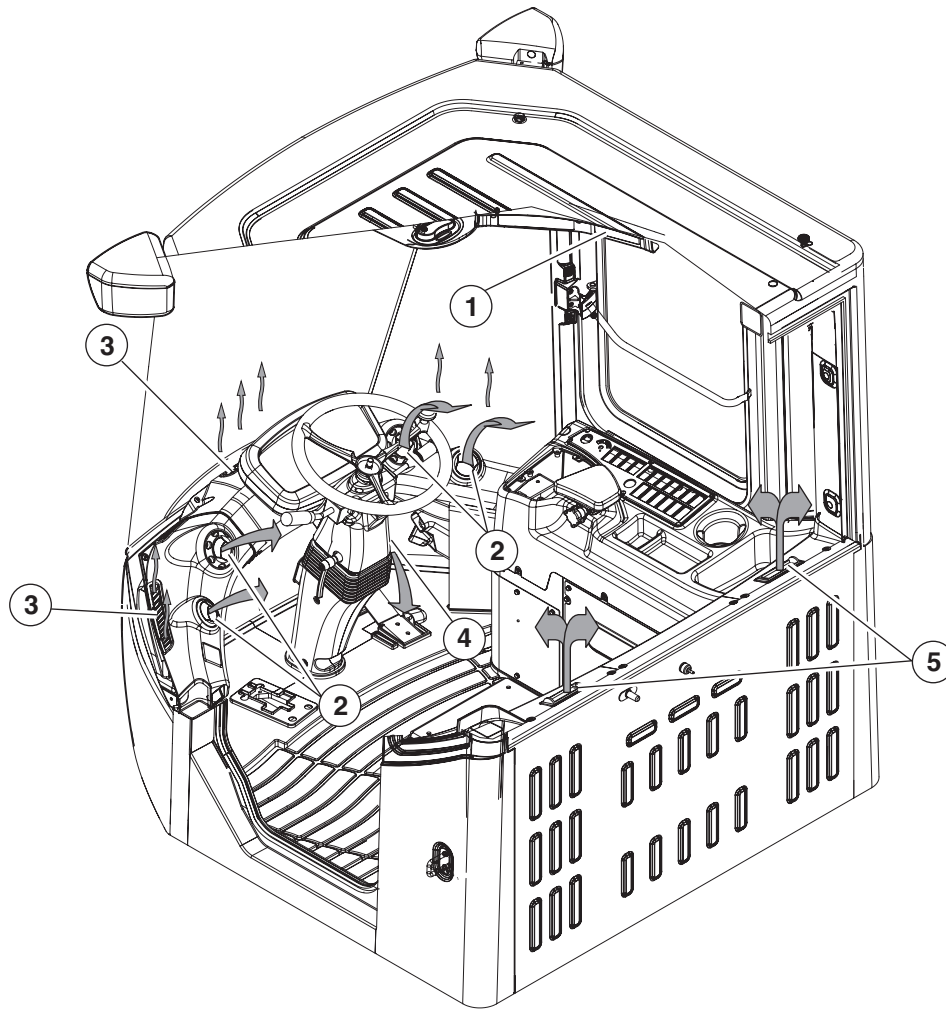

FG006506

Figure 89

Reference Number	Description
1	Operation Panel
2	Front Nozzle (Air Conditioner)
3	Front Nozzle (Defroster)

Reference Number	Description
4	Foot Nozzle
5	Rear Nozzle

The heater and air conditioner are combined into one unit to the right side of the operator's seat. If necessary, the operator can control interior cabin temperature using the operation panel.

# Operation Panel

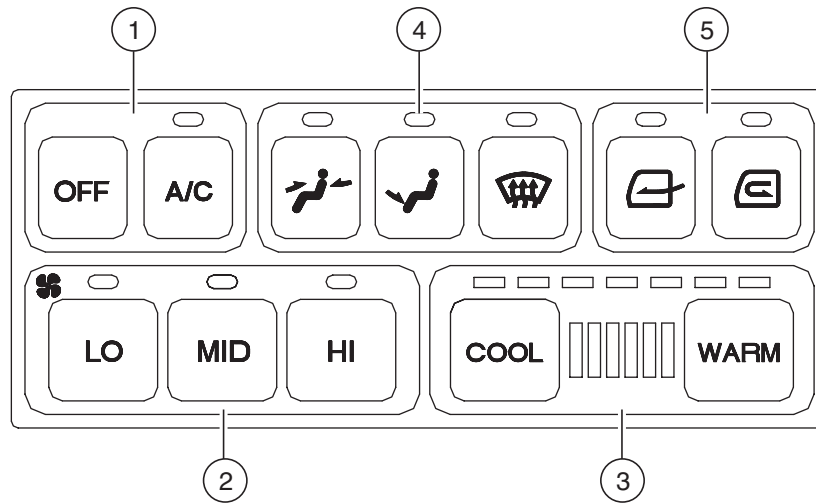

FG003966

Figure 90

Reference Number	Description
1	Fan and Air Conditioner Switch
2	Blower Fan Switches
3	Temperature Control Switch

Reference Number	Description
4	Selector Switch for Wind Direction
5	Ventilation Selector Switch

When a switch is selected, the LED above that switch will turn "ON" and give an activation sound.

When the light switch is turned "ON," the panel LED's will turn "ON."

## 1. Fan and Air Conditioner Switch

- A. "OFF" Switch - Turns "OFF" the heater and air conditioner unit.
- B. "A/C" Switch - Turns "ON" the air conditioner when one of the blower switches is activated.

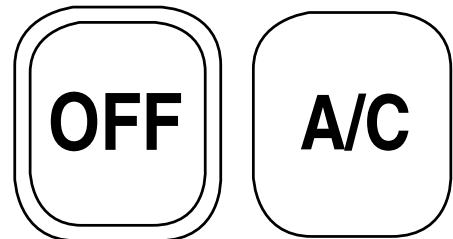

Figure 91

HAOC930L

## 2. Blower Fan Switches

These switches are used to control the speed of the blower fan.

- A. "LO" Switch - Used for low blower speed.
- B. "MID" Switch - Used for intermediate blower speed.
- C. "HI" Switch - Used for high blower speed.

**NOTE:** *If you do not select a blower speed the heater and air conditioner will not work.*



Figure 92

HAOC940L

## 3. Temperature Control Switch

The temperature control consists of 24 stages. An LED is turned "ON" for every three stages. Whenever pushing it, it changes in stages. Pushing it continuously, it changes continuously.

- A. "COOL" Switch - Lowers the temperature.
- B. "WARM" Switch - Raises the temperature.

### LED COLOR STATUS

Green LED - Air conditioner. Full green, maximum operation of air conditioner.

Red LED - Heater. Full red, maximum operation of heater.

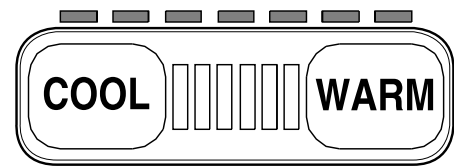

Figure 93

HAOA860I

## 4. Selector Switch for Wind Direction

- A. Used to direct air flow to upper portion of operator's cabin.

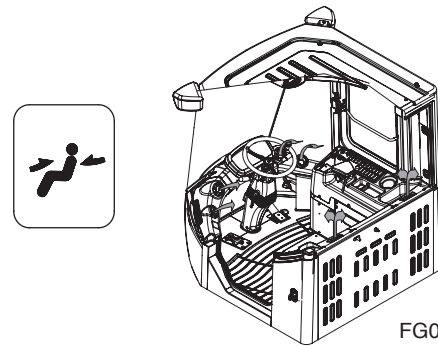
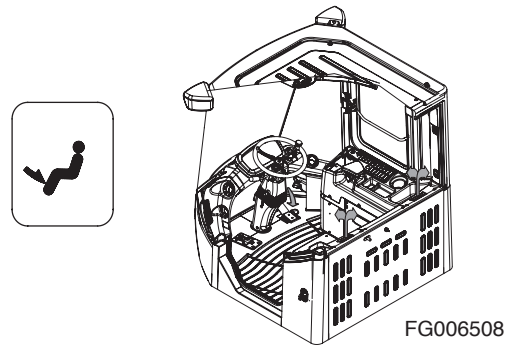

Figure 94

FG006507

- B. Used to direct air flow to lower portion of operator's cabin.



- C. Used to direct air flow for defrosting front window of operator's cabin.

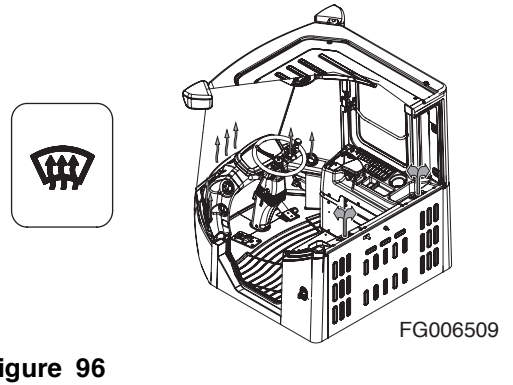

## 5. Ventilation Selector Switch

- A. "A" Switch - Draws fresh air into operator's compartment.
- B. "B" Switch - Recirculates air within the operator's compartment. Used to rapidly reduce condensation on windows.

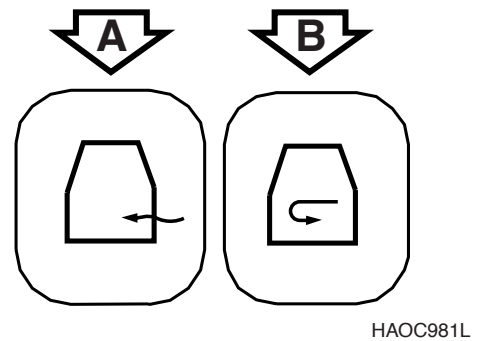

## Memory Function of Used Mode

The air conditioner panel has a memory function. When the starter switch is turned "OFF" the settings for the panel will be stored. When the excavator is started, the last setting will be used.

## Additional Operating Instruction

A proper interior temperature in summer is 5 - 6° C (10 - 12°F) less than the outdoor temperature.

Operate the air conditioner from twenty - thirty minutes a week to circulate the refrigerant in the system.

**NOTE:** *The blower switch must be on "LO" speed.*

**NOTE:** *The outer air conditioner filter must be cleaned out every 50 hours and replaced with a new one every 500 hours. The inner air conditioner filter must be cleaned out every 500 hours and replaced with a new one every 1,000 hours.*

**NOTE:** *In the event that the unit is being operated in a dusty environment, the cleaning and replacement must be performed more frequently.*

If operating the air conditioner or heater for a long time, operate the ventilation switch, and when smoking, vent the air to the outside to prevent irritation to eyes.

# STEREO / CD PLAYER (OPTIONAL)

Before operating the stereo or CD player, read operation manual enclosed with stereo or CD player.

## Stereo

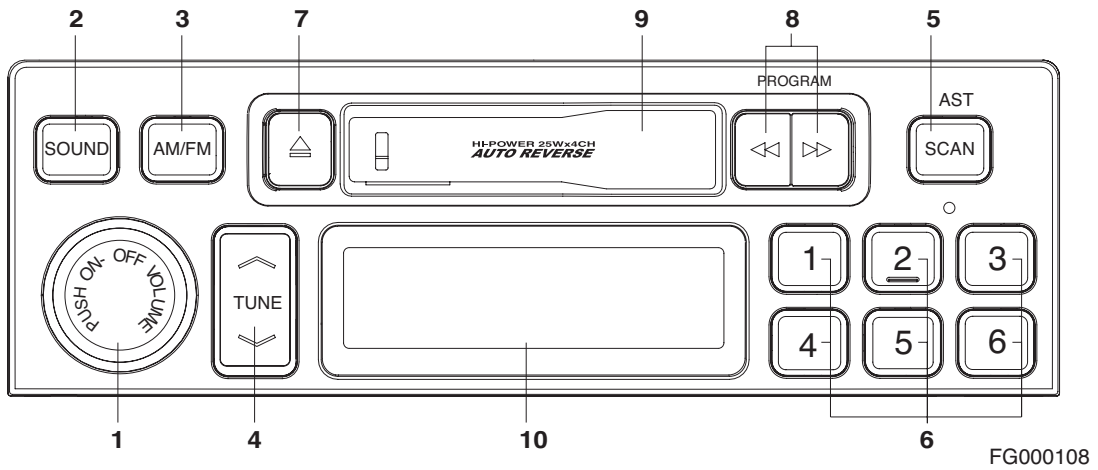
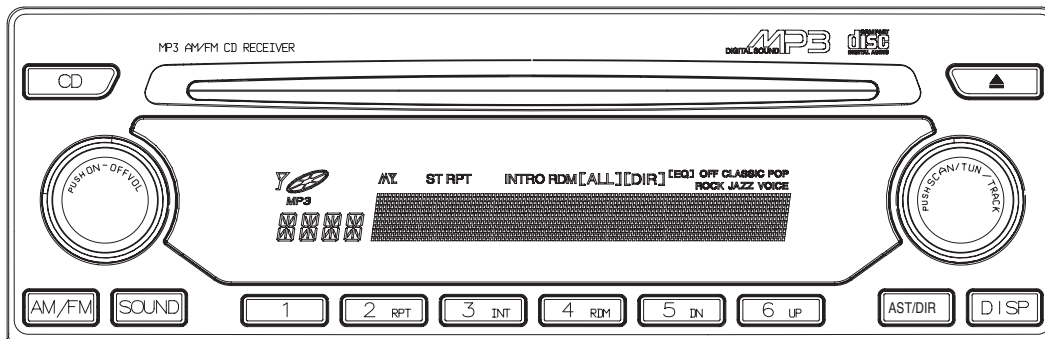

Figure 98

Reference Number	Description
1	Power / Volume Control
2	Sound Mode Selector
3	Band Selection
4	Tuning Up / Down
5	Scan Function / Auto Store

Reference Number	Description
6	Preset Station
7	Tape Ejection
8	Fast Forward / Rewind
9	Tape Loading Slot
10	LCD

## CD Player (Optional)



FG000109

Figure 99

# SEAT ADJUSTMENT



Whenever operator or operating condition has changed, check to see that seating position is suitable for the condition at hand. Always fasten your seat belt while operating vehicle. Adjust backrest so that the operator can fully reach and operate pedals.

---

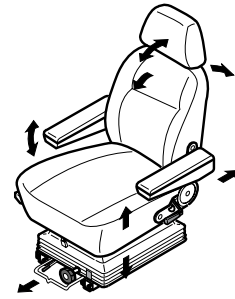

Figure 100

HAOB110L

## 1. Adjusting Seat Forward/Backward Lever

Holding lever (3, Figure 101), raise it, while pushing or pulling seat to desired position. Release lever once desired position is reached. Adjustment range is 160 mm (6.3 in).

## 2 and 3. Adjusting Seat's Angle and Height Lever

Pulling left lever (3, Figure 101) up allows rear part of seat to be moved up or down. Pulling lever (2) up allows front part of seat to be moved up or down. Adjust seat according to operator's size and work conditions. Adjustment range is 60 mm (2.36 in) for both front and rear.

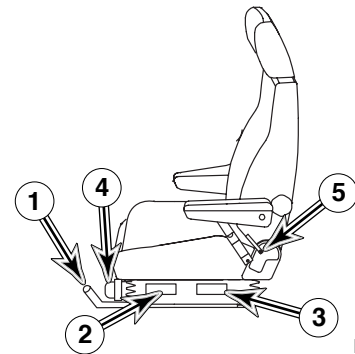

Figure 101

HBOI350L

## 4. Weight Adjustment Knob

Turning knob (4, Figure 101) to right makes suspension harder. Turning knob to left makes suspension softer. Adjust according to operator's weight by checking weight indicator dial. Adjustment range is from 50 - 120 kg (110 - 265 lb).

## 5. Backrest Adjustment Lever

Pulling up right lever (5, Figure 101) allows seat backrest to be moved forward or backward.

## 6. Angle Adjustment of Armrest

Adjustment angle of left and right armrest (6, Figure 102) is done by turning a dial in bottom of armrest. When you adjust angle, manually raise armrest before turning dial.

## 7. Headrest

Headrest (7, Figure 102) can be adjusted forward/backward and up/down. Move it by holding both sides.

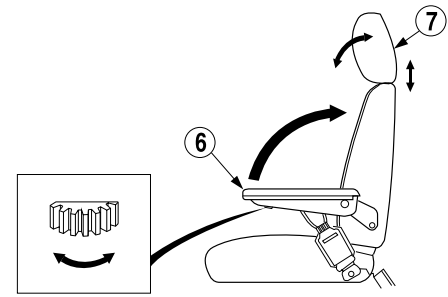

HAOB130L

Figure 102

## Recommendations for Limiting Vibrations

1. Select the right machine, equipment and attachments for a particular application.
2. Replace any damaged seat by a *DOOSAN* genuine part. Keep the seat maintained and adjusted.
  - Adjust the seat and suspension for the weight and size of the operator.
  - Inspect and maintain the suspension and adjustment mechanisms of the seat regularly.
3. Check that the machine is properly maintained.
  - Tire pressure, brakes, steering, linkages, etc.
4. Steer, brake, accelerate, shift gears, move the attachments and load the attachments smoothly.
5. Adjust the machine speed and travel path to reduce the vibration level.
  - Slow down if it is necessary when passing rough terrain.
  - Drive around obstacles and excessive rough terrain conditions.
6. Keep the terrain on work sites where the machine is working and traveling in good condition.
  - Remove any large rocks or obstacles.
  - Fill any ditches and holes.
  - Provide machines for and schedule time to maintain the terrain conditions.
7. Travel over longer distance (e.g. on public roads) at adjusted (medium) speed.
  - Always adjust the speed for preventing bouncing.

# SEAT BELT



## WARNING!

Seat belt is for operator's safety and should always be worn. Before driving machine, adjust seat to desired position for maximum comfort and machine control, then fasten seat belt. Seat belts must be worn across pelvic region and adjusted snugly to lessen chance and severity of injury in event of an accident. Never fasten a seat belt across abdomen.

Under no circumstances should operator be standing in cabin when operating wheel loader.

Do not adjust seat position while vehicle is moving because a loss of control may result. Stop machine, apply parking brake, and then adjust seat.

Always, check condition of seat belt and belt bracket before fastening it. Do not use it with twists in it. Replace belt or bracket if damaged or worn.

## Seat Belt Locking and Unlocking

Insert belt end (1, Figure 103) into buckle (2). Pull belt to check that belt end is locked into buckle.

Adjust belt length so that it comfortably tight against operator's pelvic region (hipbone).

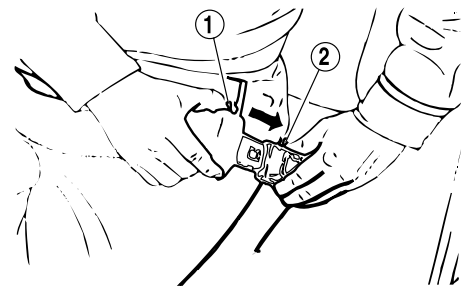

HAOB140L

Figure 103

Press button (3, Figure 104) in center of buckle (2) and pull out belt (1) to unlock.

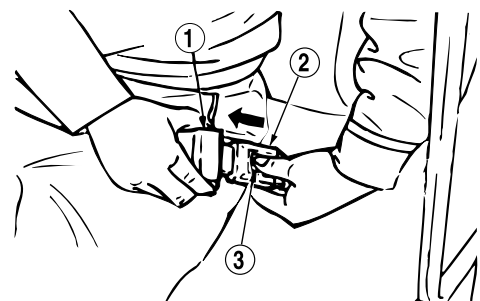

HAOB150L

Figure 104

# DOOR SIDE LATCH

1. Door side latches (1. LH, Figure 105) and (2. RH, Figure 106) are used to secured the doors (RH, LH) to the side of the cabin when they are opened.

**NOTE:** *Keep the door closed and locked when machine is not in use.*

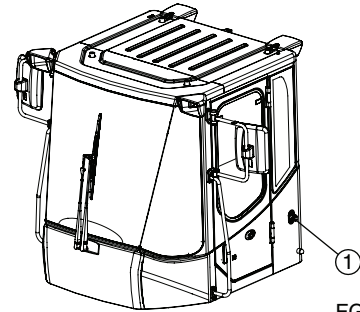

FG003894

Figure 105

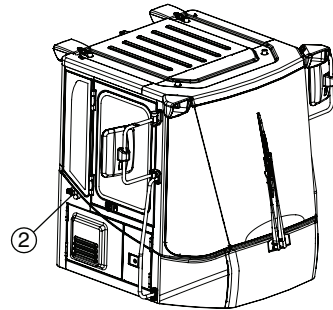

FG003895

Figure 106

2. The RH side door, which is emergency exit from the cabin, can be opened in two positions.

Position 1. (ventilation position)

- Open the window and secured it with the lock bar. (A, Figure 107)

Position 2. (full opened position)

- Open the window and push it to backward

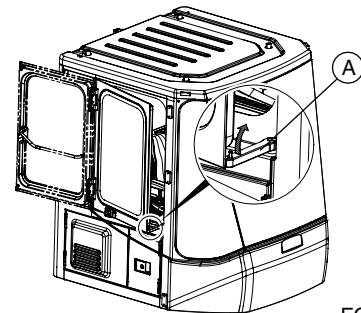

FG003896

Figure 107

3. To release doors from both sides of the cabin. Pull the handles (Figure 108) in the direction of arrows. The handles are located on both sides of the operator's seat.

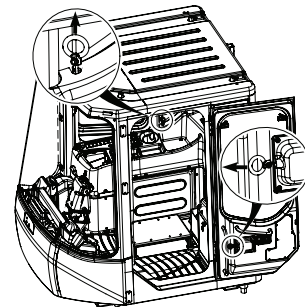

FG003897

Figure 108

# ARM REST

Knob (1, Figure 109) is used to allow armrest to be moved to the most convenient position for the operator. Loosen knob and move armrest (2, Figure 109) to desired position. Tighten knob.

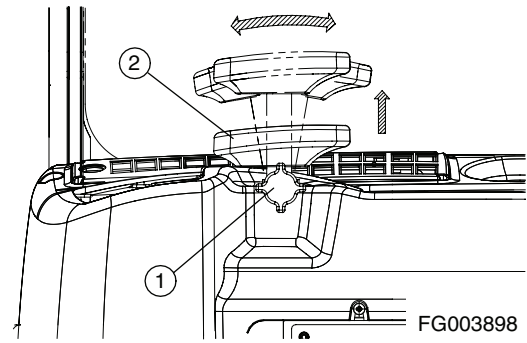

Figure 109

# FUSE BOX/RELAY/ENGINE EMERGENCY STOP SWITCH

## Fuse Boxes

There are two fuse boxes inside the cabin.

Fuse boxes are on the upper side of the electric box. A usage diagram of fuses is shown inside of fuse box. Spare fuses are mounted on the inside of fuse box cover (10A - Qty. 1, 15A - Qty. 1, 20A - Qty. 1 and 30A - Qty. 1).



## WARNING!

If any fuse is blown, turn "OFF" the starter switch and shut off the power supply. Remedy the cause if needed and replace the fuse with a new one.

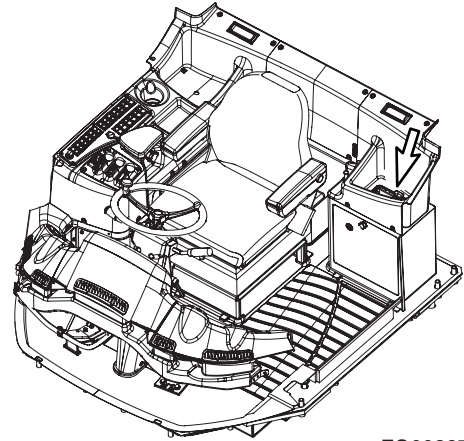

FG003971

Figure 110

Fuse Box One		
No.	Name	Capacity
1	Rear Wiper, Window Washer	10A
2	Parking Brake, Pilot Cut Off	10A
3	Rotating Beacon (Option)	10A
4	CCTV (Option)	10A
5	Spare	10A
6	Cigar Lighter	10A
7	Turn Signal Light, Hazard Light, Indicate Light	10A
8	Starter Switch, Hour Meter, Cabin Light	10A
9	Air Conditioner, Heater	30A
10	Headlight	20A
11	Transmission	15A
12	Condenser Fan, Cooling Fan	15A
13	ECU (1)	15A
14	ECU (2)	15A

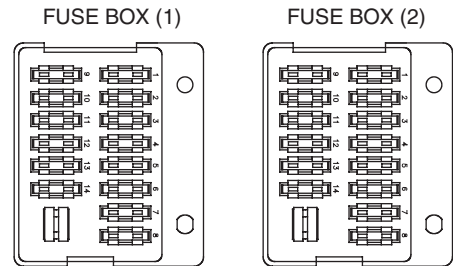

FG003972

Figure 111

<b>Fuse Box Two</b>		
<b>No.</b>	<b>Name</b>	<b>Capacity</b>
1	Gauge Panel	10A
2	Stop Light	10A
3	Auto-detent, LIS (Option)	10A
4	Electric Steering (Option)	10A
5	Emergency Steer (Option)	10A
6	Horn, Front Wiper	10A
7	Position Light (Left)	10A
8	Position Light (Right)	10A
9	Fuel Heater (Option)	30A
10	Work Light (Rear)	20A
11	Mirror Heater	15A
12	Work Light (Front)	15A
13	Stereo, Clock, 12V Socket	15A
14	Memory Backup, Pilot Buzzer	15A

## Relays

The relays are in the electrical box on the left side in the operator's cabin. If the problem is not solved after replacing the fuse, check the function of the relay.

MIRROR HEATER	LIS	ELEC. STEERING(1)	ELEC. STEERING(2)	ELEC. STEERING(3)	FUEL HEATER		
SAFETY START	BACK UP	COMPRESSOR	STEREO	DISPLAY ILL.	ALARM(1)	ALARM(2)	CLOCK
HEAD LAMP	REAR LAMP	WIPER	CONDENSER FAN	RETURN TO DIG.	RASE	FLOAT	HORN

FG003973

Figure 112

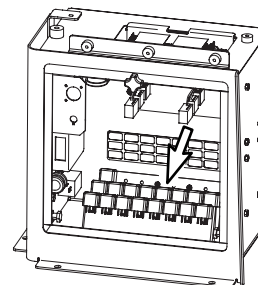

FG003974

Figure 113

## Circuit Breaker

A circuit breaker is next to the relay by the batteries at back of unit under engine compartment hood. When a short circuit or an overload occurs, the circuit breaker automatically cuts off current, thus preventing electrical wires from burning.

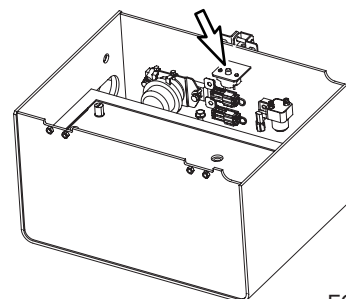

FG003975

Figure 114

## Fusible Link

A fusible link (Figure 115) is in the battery box.

If the engine does not crank, first check that the starter switch is turned "ON" and that no power is available (No indicator lights will light.). Check that the "A" portion (Figure 116) of the fusible link is not broken or burned through. Replace the fusible link if damage and investigate cause.

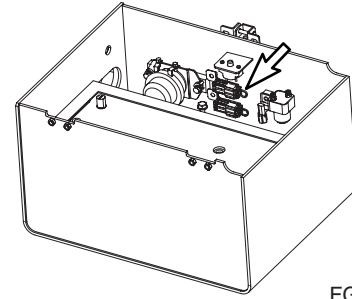

FG003978

Figure 115



## WARNING!

When changing the fusible link, replace the fusible link with the same capacity part. Otherwise, a fire could break out in the wiring harness and/or other components of the circuit. Always use original *DOOSAN* parts.

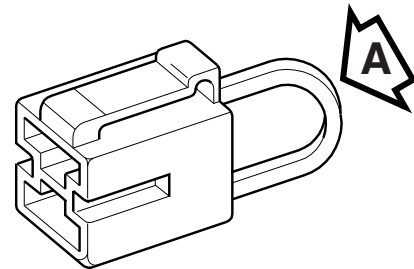

HAOB100L

Figure 116

## Engine Emergency Stop Switch

If the engine does not shut down when using the starter switch, it can be stopped by moving the engine emergency stop switch to the "I" (Emergency Stop) position.

- O. In this position, the engine emergency stop system is "OFF"
- I. In this position, "Emergency Stop" is selected the engine will shut down

**NOTE:** *When released, the switch will return to "O" (OFF) position*

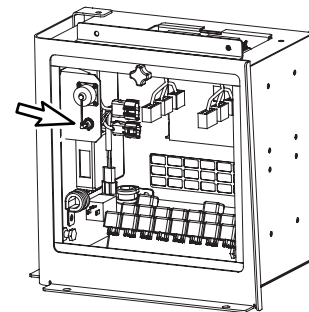

FG004340

Figure 117

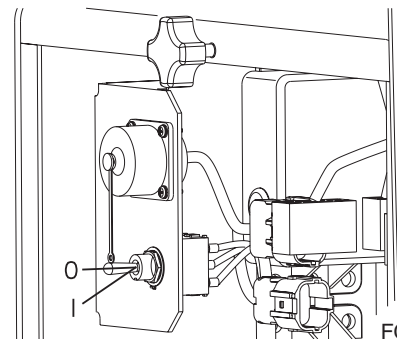

FG004341

Figure 118

# Operation



## WARNING!

---

Before operating any wheel loader, read and understand "Operating Controls" section of this manual.

---

## INSTRUMENT PANEL CONTROL FUNCTIONS

### Monitoring System

Monitoring system uses network circuits between control system and sensors installed at various machine system locations to monitor selected conditions. The monitoring systems function is to continually inform the operator of machine's condition. Displays and gauge readouts on instrument panel provide information such as engine speed, engine coolant temperature, transmission oil pressure, and electrical charge status.

## NEW MACHINE BREAK-IN PROCEDURES

All wheel loaders are inspected and adjusted before leaving the factory. However, it is required that the operator follow these steps during initial break-in period. Failure to follow these steps may result in damage to equipment or reduced performance.

1. Make sure to check all fluid levels before starting and every 8 - 10 operating hours.
2. Do all Daily maintenance and service checks.
3. For first 50 operational hours, as shown by hour meter on control console, do not exceed 80% of maximum rated engine speed.
4. At end of first 50 operational hours, drain engine oil. Replace engine oil filter and engine oil.

# ENGINE START AND STOP

## Engine Start

1. Set parking brake switch to "I" (APPLIED) position.  
This will ensure that the parking brake is "APPLIED."

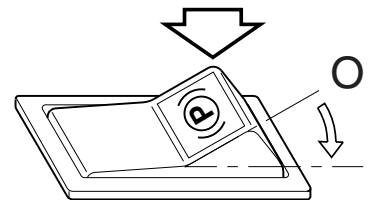

HA002019

Figure 1

2. Move all control levers to "NEUTRAL" position

---

## IMPORTANT

---

If transmission lever is not in "NEUTRAL" position,  
engine will not start.

---

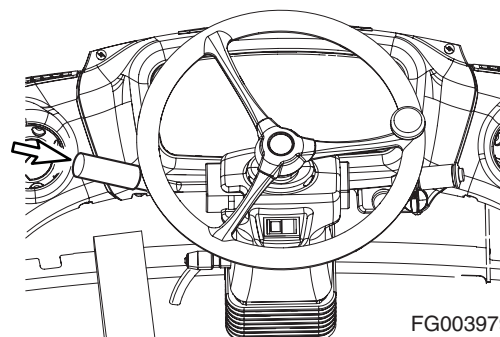

FG003979

Figure 2

3. Make sure transmission neutral lock is in the "N" (NEUTRAL LOCK) position.

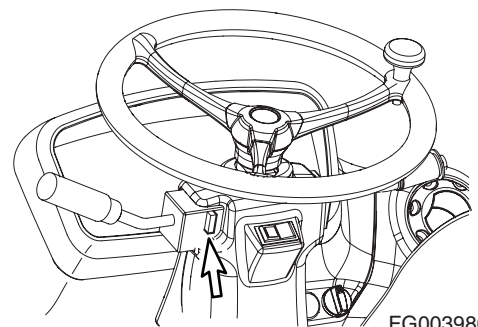

FG003980

Figure 3

- Set pilot cutoff switch to "O" (LOCK) position. This will "LOCK" pilot control valve lever (joystick).

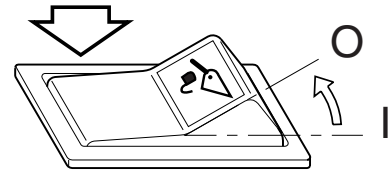

HBOI111L

Figure 4

- Set reverse fan switch to "O" (OFF) position. This will prevent damage to the cooling system during normal operation.

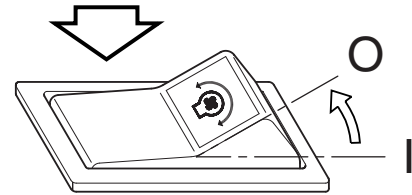

HAAH0040

Figure 5

- Rotate starter key to "I" (ON) position. All indicator lights should turn "ON."

**NOTE:** *If unit is equipped with and emergency steering system. Test system before starting engine. If system does not function properly, do not start unit. Follow test procedure given with test switch.*

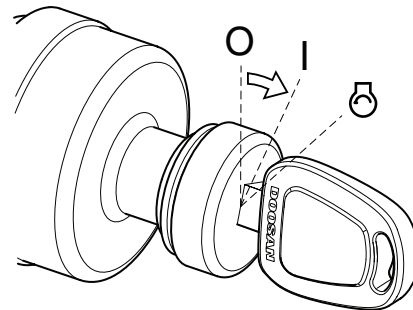

FG000084

Figure 6

- Rotate starter key to "START" position. Starter motor should crank immediately, and engine should start within a few seconds.

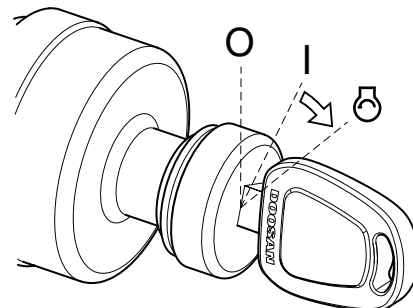

FG000085

Figure 7

8. Release starter key when engine starts. Key will return to "I" (ON) position.

---

## IMPORTANT

---

**If engine does not start after approximately fifteen seconds of cranking, release Starter Key. Wait five minutes for starter motor to cool down. Repeat step 7.**

---

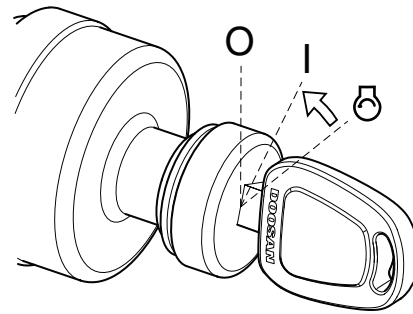

Figure 8

FG003899

9. After engine starts, check all indicator lights and gauges to be certain that all engine systems (oil pressure, oil temperature, coolant temperature, etc.) are in normal operating range. If any engine system is not normal, turn starter key to "OFF" position.

Instrument Panel Light or Gauge	Indicator Reading
Fuel Gauge	WHITE RANGE
Engine Coolant Temperature Gauge	
Transmission Oil Temperature Gauge	
Engine Oil Pressure Warning Light	OFF
Charging Warning Light	
Brake Oil Pressure Warning Light	
Parking Brake Light	ON

**NOTE:** *Parking brake indicator light turns "ON" or "OFF" according to parking brake operation regardless of engine starting.*

10. Perform "Hydraulic System Warm-up" on page 3-10.
11. Check color of exhaust smoke:
  - No color or light blue - Engine is running in good condition.
  - Black - Incomplete combustion. Check cause.
  - White or dark blue - Engine is burning engine oil. Check cause.
12. Check for usual engine vibration and noises. If any are heard or felt, investigate cause.

**NOTE:** *If engine coolant temperature gauge shows red while running, take the following action; Discontinue work and allow engine to run at "LOW IDLE." Open engine compartment cover for good ventilation. Once engine temperature gauge returns to the green zone, shut down engine. After engine has cooled, check coolant level, look for signs of leaks, clogged or dirty radiator fins (radiator core), and fan belt tension.*

## Cold Weather Engine Start

1. Set parking brake switch to the "I" (APPLIED) position. This will ensure that the parking brake is "APPLIED."

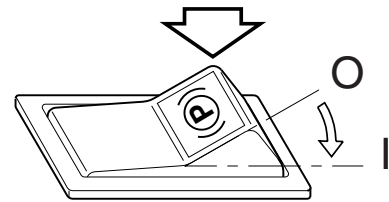

HA002019

Figure 9

2. Move all control levers to "NEUTRAL" position.

---

### IMPORTANT

---

If transmission lever is not in "NEUTRAL" position, engine will not start.

---

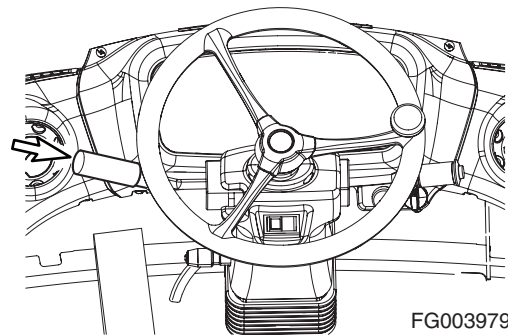

FG003979

Figure 10

3. Make sure transmission neutral lock is in the "N" (NEUTRAL LOCK) position.

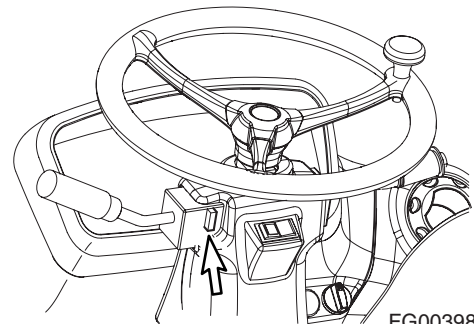

FG003980

Figure 11

- Set pilot cutoff switch to "O" (LOCKED) position. This will "LOCK" pilot control valve lever (joystick).

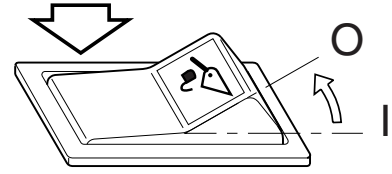

HBOI111L

Figure 12

- Set reverse fan switch to "O" (OFF) position. This will prevent damage to the cooling system during normal operation.

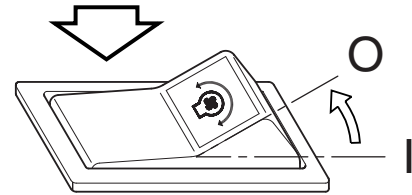

HAAH0040

Figure 13

- Turn starter switch to the "I" (ON) position (Figure 14). When preheat cycle is completed, the preheat indicator light (1, Figure 15) will turn "OFF."

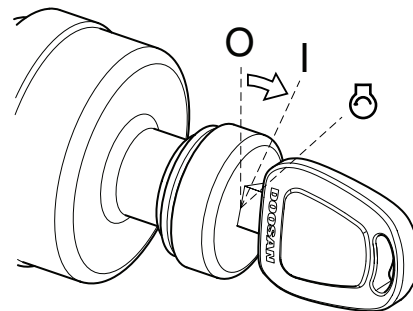

FG000084

Figure 14

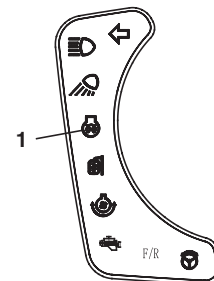

FG004193

Figure 15

7. Rotate starter key to "START" position. Starter motor should crank immediately, and engine should start within a few seconds.

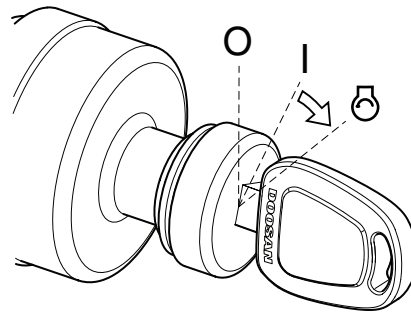

FG000085

Figure 16

8. Release starter key when engine starts. Key will return to "I" (ON) position.

---

## IMPORTANT

---

**If engine does not start after approximately fifteen seconds of cranking, release starter key. Wait five minutes for starter motor to cool down. Repeat step 7.**

---

9. After engine starts, check all indicator lights and gauges to be certain that all engine systems (oil pressure, oil temperature, coolant temperature, etc.) are in normal operating range. If any engine system is not normal, turn starter key to "O" (OFF) position.
10. Perform "Hydraulic System Warm-up – Cold Weather" on page 3-10.

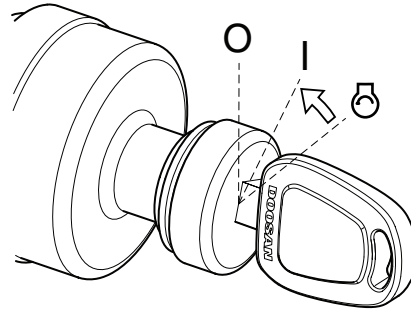

FG003899

Figure 17

## Starting with Auxiliary Batteries



Wear safety glasses.

Never connect negative leads to positive terminals and vice versa.

**DO NOT** connect auxiliary or booster battery ground terminal directly to battery terminal. Locate and use a ground point on machine frame.

Depleted batteries generate hydrogen gas. Electrical sparks around or near batteries can cause an explosion.

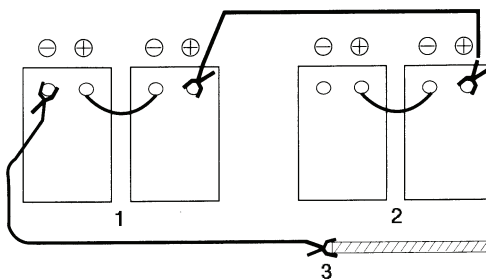

0042A

Figure 18

Reference Number	Description
1	Auxiliary Batteries
2	Depleted Batteries

Reference Number	Description
3	Ground Auxiliary Batteries to Machine Frame

If batteries are drained during starting procedures, you can jump start engine using auxiliary or booster batteries according to following procedures:

1. Connect positive jumper cable from auxiliary batteries to depleted batteries (Figure 18).
2. Connect negative jumper cable from auxiliary batteries to a ground point on machine frame. **DO NOT CONNECT DIRECTLY TO NEGATIVE BATTERY TERMINAL.**
3. Follow normal engine starting procedures.
4. After engine has started, remove negative jumper cable, and then positive cable.

## Engine Shut Down

1. Move transmission lever to "NEUTRAL" position.

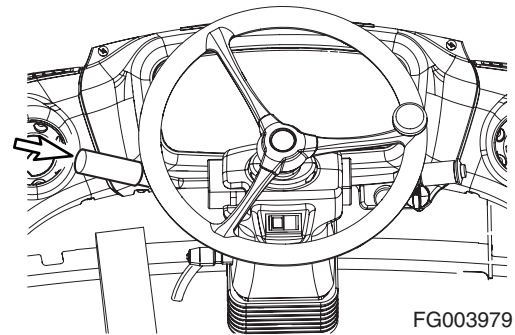

Figure 19

2. Make sure transmission neutral lock is in the "N" (NEUTRAL LOCK) position.

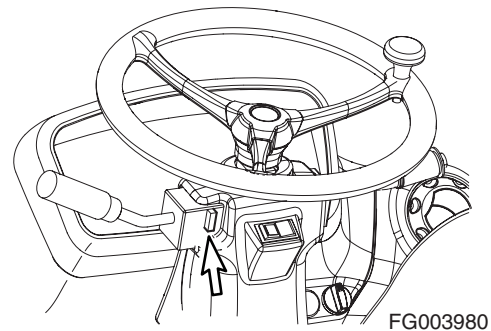
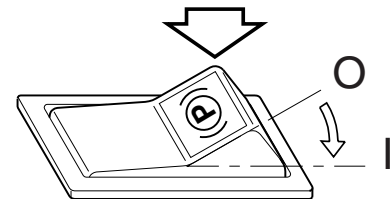

Figure 20

3. Set parking brake switch to the "I" (APPLIED) position. This will ensure that the parking brake is "APPLIED."



HA002019

Figure 21

4. Set bucket on ground.
5. Put pilot cutoff switch to "O" (LOCK) position. This will "LOCK" pilot control valve lever (joystick).
6. Allow engine to idle for one - two minutes to cool down.

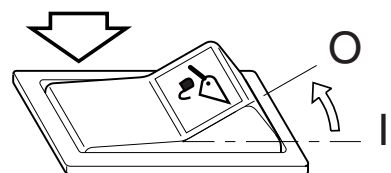

HBO1111L

Figure 22

7. Rotate starter key to "O" (OFF) position. Remove key.

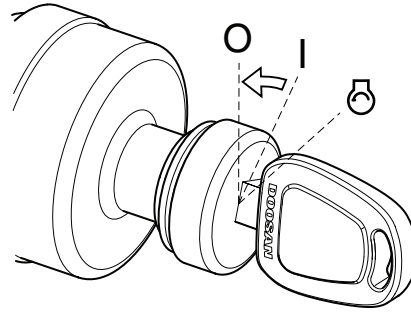

FG003900

Figure 23

## Hydraulic System Warm-up

1. Correct operating temperature of hydraulic oil is 50° - 80°C (120° - 175°F). Make sure to follow procedures listed below for hydraulic fluid warm-up.
2. Run engine at idle (no load) for five minutes.
3. Run engine for approximately five minutes at middle of speed range, without a load.
4. Cycle bucket until bucket cylinder bottoms out (extended and retracted) without a load to circulate the oil through the system. Do this for five minutes.

**NOTE:** *Do not allow cylinders to pass hydraulic oil over relief valve for more than twenty seconds at a time.*

5. Cycle boom, and bucket about five times without a load to circulate oil through system.

## Hydraulic System Warm-up – Cold Weather

1. Follow Steps 1 through 3 in "Hydraulic System Warm-up."
2. Do not operate machine at full speed until system has fully warmed up.
3. If working speeds continue to be slow, repeat initial hydraulic warm-up procedures again. If repeating warm-up procedures does not improve working speeds, continue to operate, but use extreme caution because machine function may be erratic.

# MACHINE TRAVEL

---

## WARNING!

If vehicle is moved while parking brake is engaged, serious damage to parking brake disk will result.

Select a transmission gear that is appropriate for top speed that will be traveled. Choosing a gear that is too high will reduce acceleration and will unnecessarily heat transmission converter oil.

Never place transmission in "NEUTRAL" when going down a hill. Over speeding transmission can damage transmission gears.

Never change direction of vehicle travel at high speed. Serious damage to transmission will result.

---

1. Unlatch frame lock plate between front and rear frames before traveling. Secure lock plate to rear frame (Figure 24).

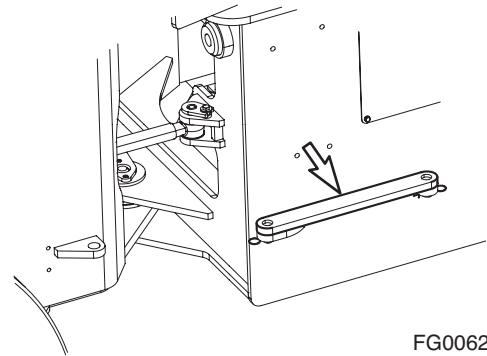

Figure 24

2. Set pilot cutoff switch to "I" (UNLOCKED) position. Raise bucket to a height of 20 - 30 cm (8 - 12 in) above the ground. Tilt bucket completely back.

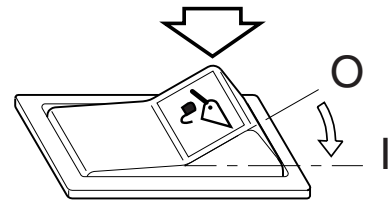
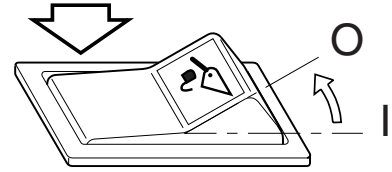

Figure 25

3. Set pilot cutoff switch to "O" (LOCKED) position. This will prevent boom and bucket from accidentally moving during travel, as a result of accidentally touching pilot control valve lever (joystick).



HBO111L

Figure 26

4. Press brake pedal.

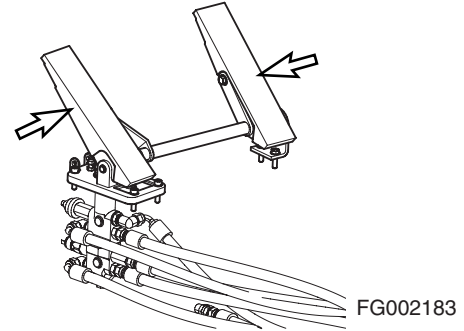

Figure 27

5. Set transmission neutral lock is in the "D" (DRIVE) position.

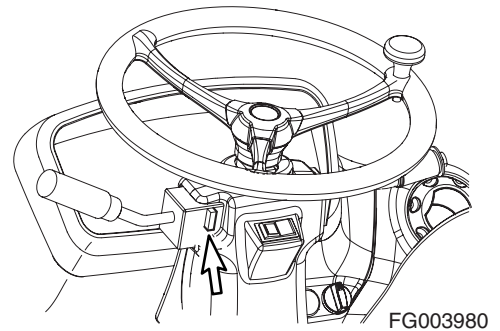
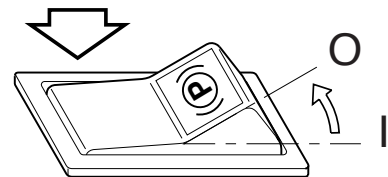

Figure 28

6. Set parking brake switch to the "O" (RELEASE) position. This will "RELEASE" the parking brake.



HAOP043L

Figure 29

7. Place transmission lever in desired gear. Shift gears one by one. Do not skip from 1st to 3rd, for example.
8. Shift transmission lever to "FORWARD" position.

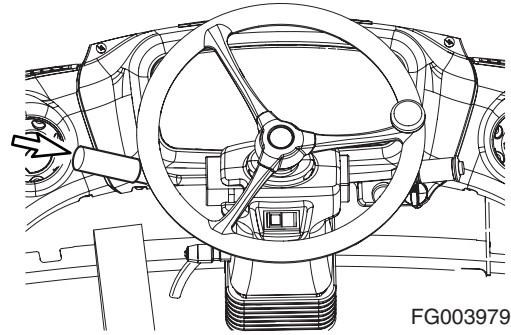

Figure 30

9. Release the brake pedal while slowly pressing the accelerator pedal.



## WARNING!

---

When traveling at high speed or on a steep hill, do not make sharp changes in direction. This could cause vehicle to overturn.

When traveling or changing direction, always look carefully to be certain that no one is in path of vehicle.

---

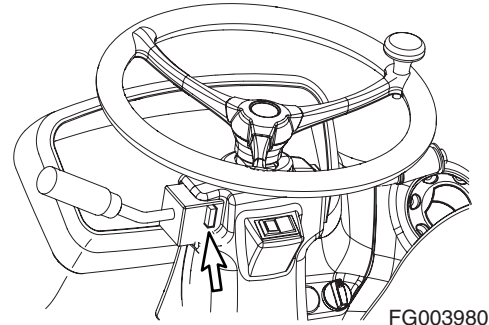

Figure 31

# MACHINE SHUT DOWN

1. Ease off throttle and apply travel brakes.

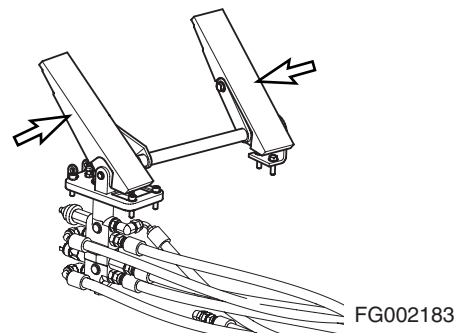

Figure 32

2. Put transmission lever in "NEUTRAL."

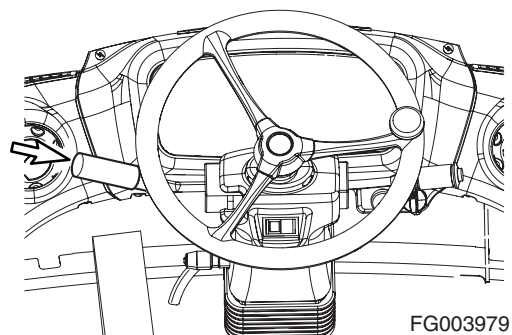

Figure 33

3. Set transmission neutral lock is in the "N" (NEUTRAL LOCK) position.



## CAUTION!

"LOCK" transmission lever. Whenever machine is parked, "LOCK" transmission lever in "NEUTRAL" to prevent accidental machine movement.

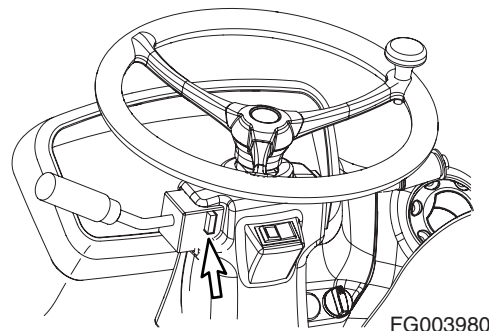
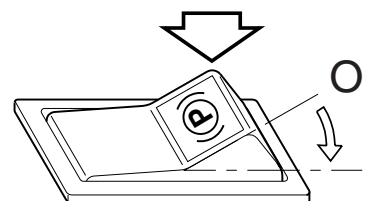

Figure 34

4. Set parking brake switch to the "I" (APPLIED) position. This will ensure that the parking brake is "APPLIED."



HA002019

Figure 35

5. Set bucket on ground.
6. Set pilot cutoff switch to "O" (LOCKED) position. This will lock pilot control valve lever (joystick).
7. Allow engine to idle for one - two minutes to cool down. Stopping a turbocharged engine without a cool down period can seriously damage turbocharger.

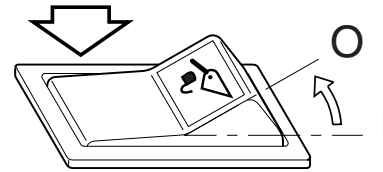

HBO111L

Figure 36

8. Rotate starter key to "O" (OFF) position. Remove key.

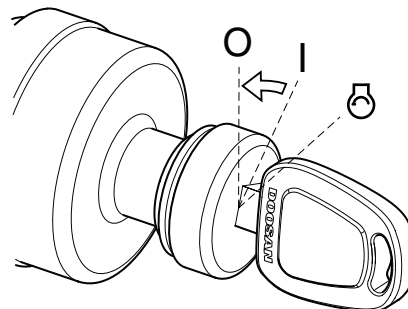

FG003900

Figure 37

9. If machine is parked on a slope, install wheel chocks in front of and behind vehicle wheels.



## WARNING!

Always secure machine with wheel chocks when parked on a slope. Leaving machine in gear will provide no braking effect because transmission clutch is hydraulically operated. When engine is turned "OFF," there is no hydraulic pressure in transmission and clutch is not engaged.

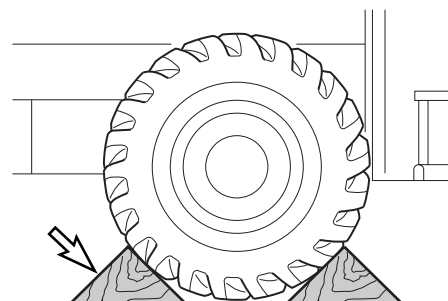

2876A

Figure 38

# F/R (FORWARD/REVERSE) TRAVEL CONTROL SYSTEM (OPTION)

An optional F/R (Forward/Reverse) travel control system can be installed as an option on the machine. With this system installed, the operator's light-hand can remain on the steering wheel during operation, and not have to manually move the transmission lever between forward and reverse.

To activate system perform the following steps:

1. Place transmission lever in "NEUTRAL."

**NOTE:** *Do not move the transmission lever out of "NEUTRAL." If the lever is moved, the system will be deactivated.*

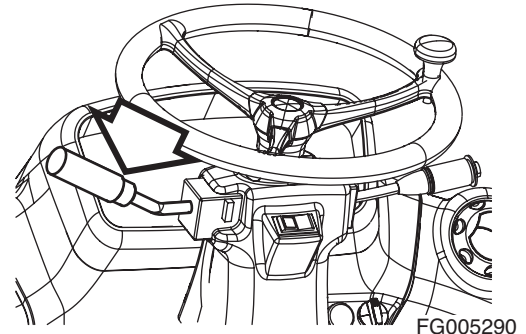

Figure 39

2. Press F/R selector switch to the "I" position, and then release. The switch will return to the "O" position, but the system will be activated. When system is activated, the F/R selector indicator light (Figure 41) will be turned "ON."

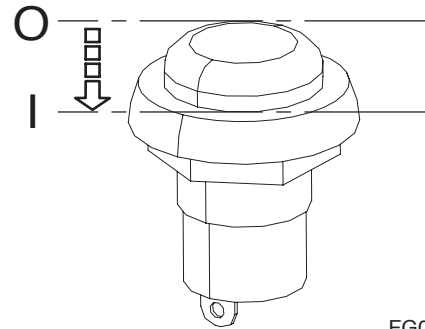

Figure 40

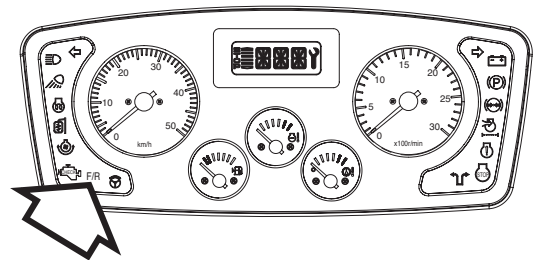
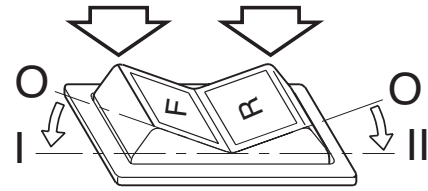

Figure 41

3. The F/R control switch is then used to control the travel direction of the machine.
  - O. In this position, the machine is in "NEUTRAL."
  - I. In this position, the machine travels "FORWARD."
  - II. In this position, the machine travels in "REVERSE."
4. The F/R travel control system will stay activated until one of two things happen.
  - A. The transmission lever is moved out of "NEUTRAL" into "FORWARD" or "REVERSE."
  - B. The starter switch is turned "OFF."

When the system is deactivated, the F/R selector indicator light (Figure 41) will be turned "OFF."



BSO0410L

Figure 42

## ADDITIONAL BRAKING

Machine hydraulic system can supply additional dynamic braking force during travel. To accomplish this, move pilot control valve lever (joystick) to crowd position and hold it there. Hydraulic pump will be driven to supply output at maximum pressure (relief pressure). Energy expended to drive pump, will slow engine speed. Additional dynamic braking, along with proper gear selection, can be used to slow a vehicle that is being driven down an incline.

# BOOM RAISE KICK-OUT

Placing boom lever in "Boom Raise Detent" position will lock boom lever in raise boom position. Boom will raise until trip plate (1, Figure 43) makes contact with boom height limit switch (2, Figure 43). When limit switch is tripped, boom will stop raising and boom lever will automatically be returned to "NEUTRAL" position. Trip plate can be adjusted to control maximum height that boom can be raised.

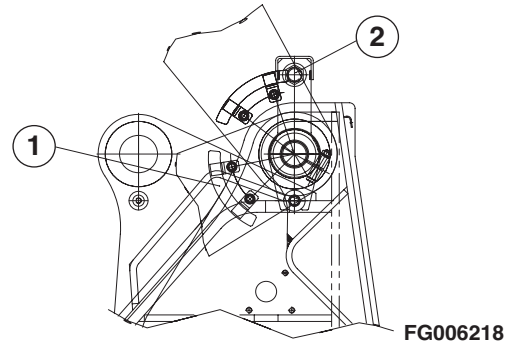

Figure 43

---

## IMPORTANT

---

**Trip plate (1, Figure 43) must always be set to contact limit switch (2) before boom cylinders reach maximum extension. Maximum extension causes pump to force fluid over relief valve.**

To raise boom to maximum height, past preset height, hold boom and bucket lever in "Raise" or "Hold Raise" position until boom has reached maximum height. Then remove your hand from lever. Lever will automatically return to "NEUTRAL" position. This prevents hydraulic pump from working against relief valve (maximum pressure).

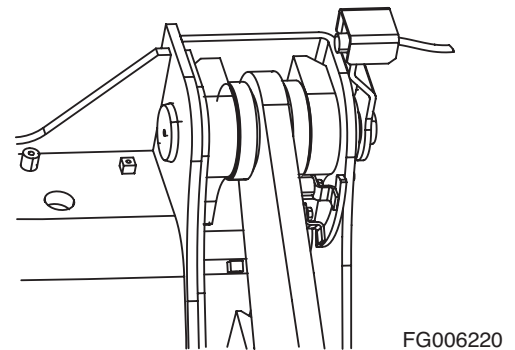

Figure 44

# BUCKET ANGLE INDICATOR

Upper left/right side of bucket includes a bracket that indicates angle of bottom of bucket. Top of bracket is parallel with bottom of bucket. If bottom of bucket is not visible, top of bracket will be visible.

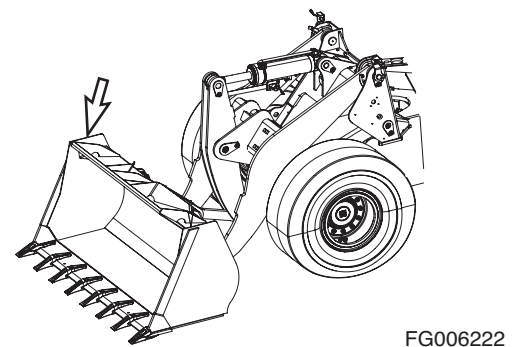

Figure 45

# BOOM LOWER KICK-OUT (OPTION)

Placing boom lever in "L" position will lock control lever in lower boom position. Boom will move downward until trip plate (1, Figure 46) makes contact with boom lower limit switch (2, Figure 46). When limit switch is tripped, boom will stop lowering and boom lever will automatically be returned to "NEUTRAL" position. Trip plate can be adjusted to control maximum height that boom can be lowered.

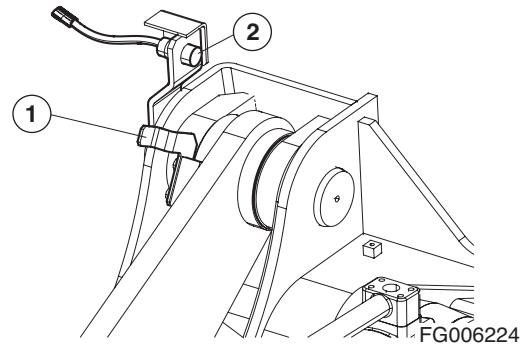

Figure 46

# ADJUSTMENT OF BUCKET POSITION SWITCH

When bucket lever is held in crowd detent position, after bucket has been dumped, bucket will pivot toward crowd position. Once full crowd position has been reached, bucket lever will automatically return to "NEUTRAL" position. If bucket is lowered after lever returns to "NEUTRAL," bucket will automatically position itself to be in a preselected digging position (usually flat). To adjust bucket to desired preselected digging position, perform the following steps.

1. Operate controls to place bucket on ground and in desired digging position (usually flat). Return bucket lever to its "NEUTRAL" position.
2. Shut down engine.
3. Loosen bolts (1, Figure 47) on bracket (2).
4. Position bracket (2, Figure 47) so that end of arm (3) is aligned with center of magnetic switch (4).
5. Tighten bolts (1, Figure 47).
6. Start engine. Raise boom, dump bucket, then move bucket lever into crowd detent position. Now lower boom and check to see that bucket has stopped at required position. A small readjustment of bracket (2, Figure 47) may be necessary.

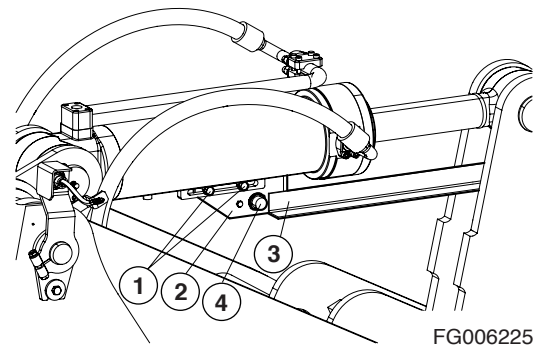

Figure 47

# TOWING MACHINE

When necessary to tow another vehicle, the tow rope must be tied to the towing pin on the counterweight at the rear of vehicle.

**NOTE:** *The loader must be used for towing only in an emergency.*



## WARNING!

---

Do not tow machine at a speed over 10 km/h (6 MPH) and do not tow machine farther than 10 km (6 mi). This will prevent damage to machine transmission that would result from lack of lubrication.

---



## WARNING!

---

When towing another vehicle on a public road, take necessary measures to let other vehicles and people know that you are towing another vehicle. Use a flag, rotating beacon light, or hazard light.

---

**NOTE:** *There are several requirements you must abide by when towing another vehicle. Learn the regulations and rules about towing another vehicle and observe them.*

If the loader is being towed by another vehicle and the engine will not start, remove the front and rear drive shafts; otherwise the transmission will rotate without being properly lubricated, causing seizure. Before removing them, apply the parking brakes and block the wheels securely.

If the engine can be started and the steering wheel and brakes function normally, have someone get on the loader you are going to tow for steering it.

Before you tow a vehicle make sure you have checked the following:

- Check the weights of your loader and the vehicle to be towed and make sure your loader has sufficient braking capacity to stop the towed load.
- Check if the vehicle to be towed can be braked and steered. If not, do not allow anyone to ride on the towed vehicle.
- Check the tow rope or tow bar for damage and make sure it has sufficient strength for the work.
- When necessary to descend a grade, another towing vehicle must be used in the rear to retard.

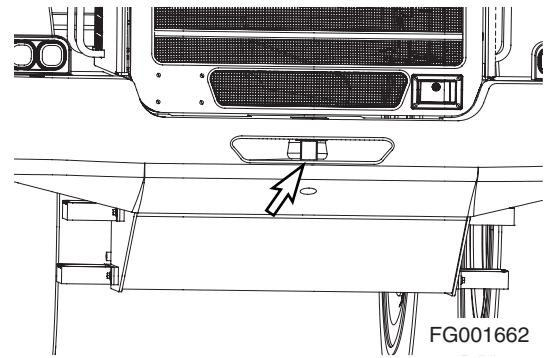

Figure 48

When towing make sure you are doing the following:

- Start slowly. A sudden start can lead to a broken tow rope.
- The tow line must be along the center line of both your loader and the vehicle to be towed.
- If you use any other towing device, refer to the Instruction Manual supplied with the towing device.
- If it is difficult to tow the loader, transport it by a trailer truck to your nearest repair shop.
- In addition to the above measures, release the parking brake if the engine will not start or the hydraulic pumps are defective.

## **IF ENGINE STALLS WHILE TRAVELING**

**BRAKE SYSTEM:** The brakes can be applied approximately 9 times by pressing the brake pedal due to the oil pressure stored in the accumulator after engine is turned "OFF" if the engine stalls while traveling, move to an out of traffic area and park. Do not pump the brake pedal at this time; otherwise the brake oil pressure will be used up, thus causing the brakes to fail.

# ALLOWABLE WATER DEPTH

The water depth is an important factor to take into consideration when the loader is working in swampy areas. Do not enter water whose depth exceeds the loader's minimum ground clearance height or is high enough to wet the bottom of the axle housing. As a rule of thumb, the allowable water depth is about 400 mm. This means that the loader should not be used in a river.

Observe the following conditions:

1. Check the water depth in advance when crossing across a river.
2. Use the same precautions before crossing across a swampy area.
3. Do not enter rivers whose river bed is steep or has a rapid flow.



**CAUTION!**

---

**Avoid use of the loader in salt water. Salt water will cause the development of rust which will shorten the life of the loader.**

---

# Inspection, Maintenance and Adjustment

## BASIC PREVENTIVE MAINTENANCE

For the machine to function satisfactorily and at lowest possible cost, a thorough maintenance program is required. This section of the manual describes the maintenance work which the operator can carry out. If certain operations require trained workshop personnel and special equipment, this will be indicated.

The intervals recommended between checks, oil changes and lubrication apply provided that the machine is used under normal environmental and operating conditions. See "Lubrication and Service Chart" on page 4-20

### Arrival and Delivery Inspection

Before the machine leaves the factory, it is tested and adjusted. The dealer must also, if the warranty is to apply, carry out "Arrival and Delivery Inspections" according to applicable form, which must be signed.

### Delivery Instructions

When handing the machine over, the dealer must give the buyer "Delivery Instructions" according to applicable form, which must be signed, if the warranty is to apply.



FG001663

Figure 1

# Service Programmes

## Warranty Inspection

Two Warranty Inspections must be carried out if the warranties are to apply. The first within 100 operating hours and the second at the latest at 1000 operating hours.

The carrying out of these inspections is a condition for the warranty to apply.

## Condition Test

A "Condition Test" is carried out at authorized dealer workshops and provides information about the general condition of the machine.

# Service Points

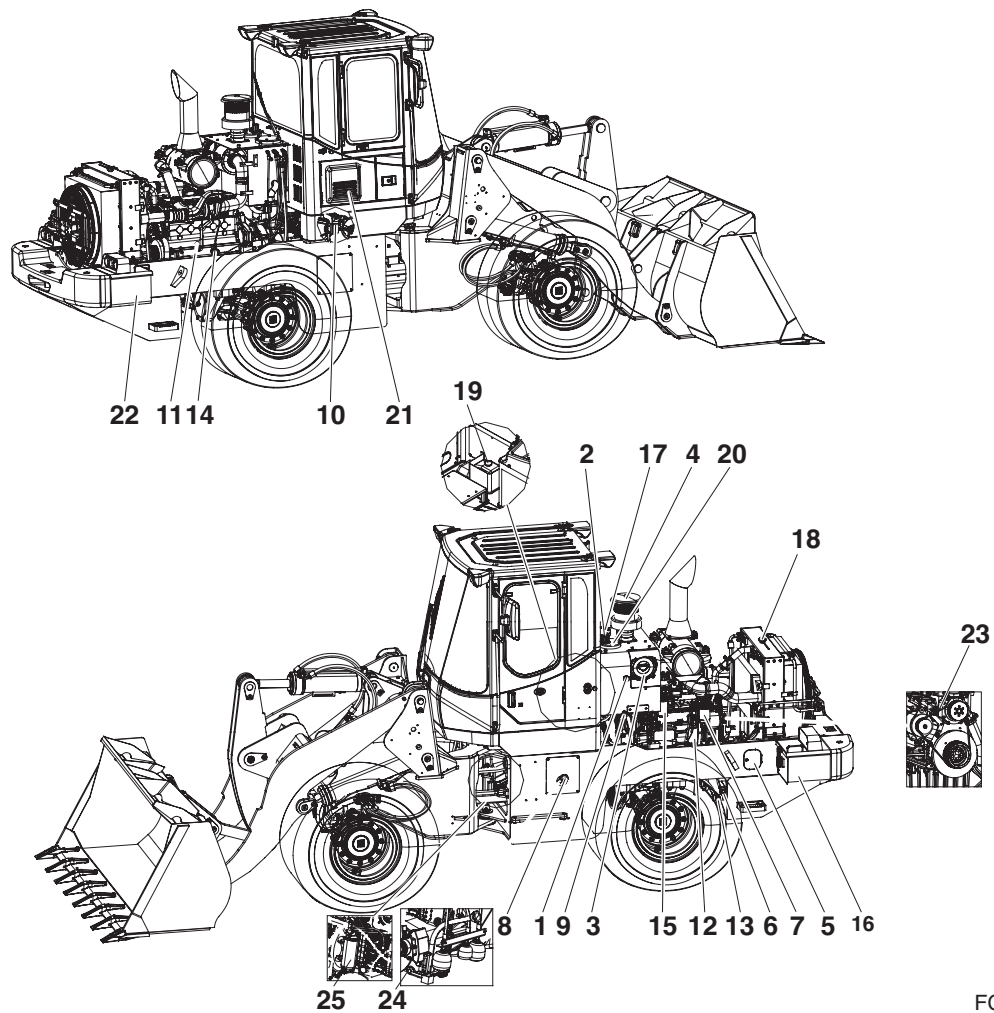

FG006219

Figure 2

Reference Number	Description
1	Level Sight Gauge Hydraulic Oil
2	Breather Of Hydraulic Oil
3	Air Cleaner
4	Pre Cleaner
5	Filling Point, Fuel
6	Draining, Coolant
7	Pre Fuel Filter
8	Filling Point, Transmission
9	Draining, Hydraulic Oil
10	Pilot Filter
11	Oil Dipstick
12	Oil Filter, Engine
13	Draining, Engine Oil

Reference Number	Description
14	Filling Point, Engine
15	Main Fuel Filter
16	Battery
17	Return Oil Filter
18	Filling Point, Coolant
19	Filing Point, Washer Fluid
20	Filling Point, Hydraulic Oil
21	Ventilation Filters, Cabin
22	Battery
23	Alternator Belt
24	Suction Strainer, Transmission
25	Oil Filter, Transmission

# SAFETY WHEN SERVICING

This section deals with the safety rules which must be followed when checking and servicing the machine. *DOOSAN* disclaims all responsibility if other tools, lifting devices or working methods are used other than those described in this publication.

Further safety rules and information and warning texts are given within the respective section.

**NOTE:** *Lifting with a jack must only be carried out by trained personnel.*



## WARNING!

---

**If work has to be carried out on the machine before it has cooled down, care must be observed with regard to risk of burns from hot liquids and hot machine parts.**

---

## Service Position

BEFORE beginning service work the machine must be parked on level ground and positioned as shown below.

AFTER completing the service, all guards must be installed and all engine covers must be closed and locked.

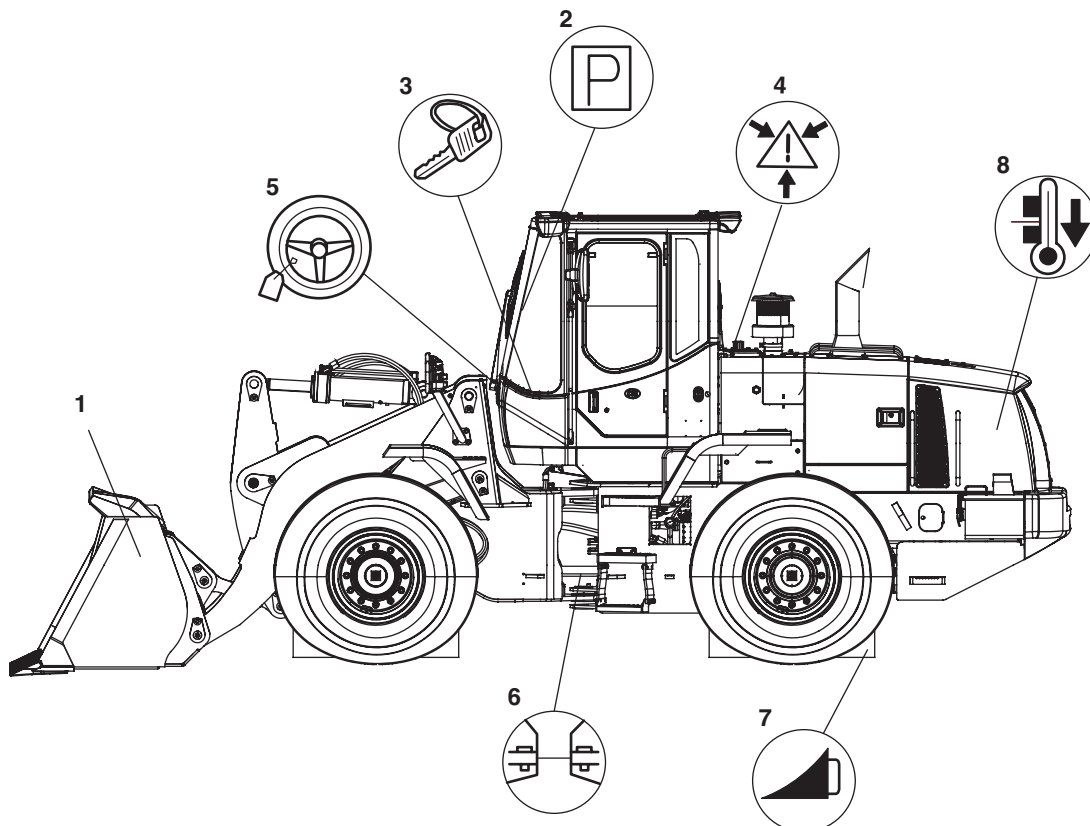

FG006221

Figure 3

Reference Number	Description
1	The bucket/attachment must be resting on the ground.
2	Apply the parking brake.
3	Shut down engine and take out the ignition key. (Does not apply when checking oil level in transmission).
4	Carefully release the pressure in pressure lines and pressure vessels to avoid risks.
5	Attach a black and yellow "Warning Tag" to the steering wheel.
6	Connect the frame joint lock.
7	Block the wheels in a suitable way (with, for example, wedges).
8	Allow the machine to cool.

## Before Service Read

- Read the Operator's Manual and the decals/labels and instructions found on the machine to obtain the required knowledge and information about the machine.
- To be able to carry out the service work in a correct way, it is important that the correct tools and equipment be used. Replace or repair broken tools and faulty equipment.
- When lifting the machine, the frame joint must be locked and the machine lifted at the eyes intended for this purpose. See "Summary of Safety Precautions for Lifting" on page 5-2

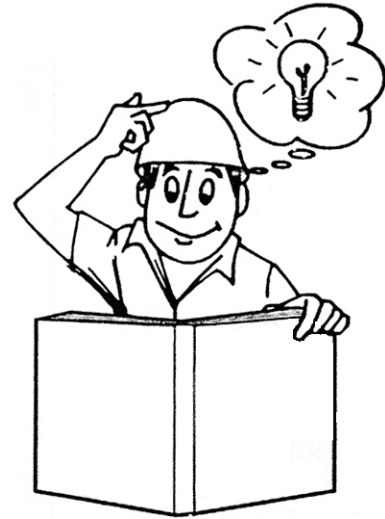

FG001666

Figure 4

- Use a hard hat, safety glasses, protective shoes and gloves and an approved respirator or other protective articles when required.
- Do not wear loose fitting clothing or jewelry.
- Keep service surfaces and handholds clean from oil, dirt and ice.

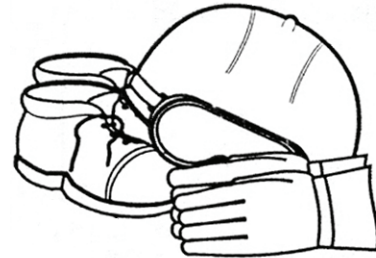

FG001667

Figure 5

- Use the stepping areas provided with antislip protection to avoid the risk of slipping. Worn, painted over, or loose protections must be replaced. Remember that high-pressure water jets when washing and spilled oil can cause the protections to loosen. Do not direct the water jet against the protections and wipe up spilled oil.
- Make sure that there is sufficient ventilation when starting the engine indoors.
- Do not exceed the maximum permissible floor load.
- Do not stand in front of or behind the machine while the engine is running.
- Use a ladder when changing light bulbs or carrying out other service work high up on the machine.

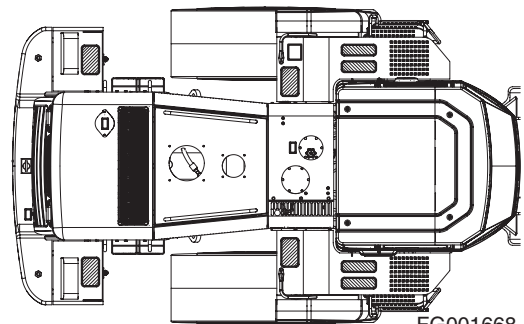

FG001668

Figure 6

- Use a long handled window scraper and brush or a ladder when cleaning the outside of the windows.
- The installation of two-way radio, lever steering or similar equipment must be carried out by a skilled person, as faulty installation may cause interference with the electronic components controlling vital machine functions.
- When carrying out service work below raised lifting arm system, the lifting arms must first have been secured (lifting arm support). In addition the control lever lockout and the parking brake must be applied.
- Take care when changing oil in engine, hydraulic system or transmission as the oil may be hot and cause burns.
- When emptying/draining oil or fuel, use a pump or a hose and collect the liquids in a suitable vessel. Spillage will damage the environment and may cause a fire. Waste oil and other contaminating liquids must be taken care of by a firm especially authorized to carry out such work.
- When operating in an area which is contaminated or dangerous to one's health, the machine must be especially equipped for this purpose. Special local safety regulations apply within such areas and also when servicing the machine.
- Shut down engine before opening engine covers etc. Make sure that no tools or other objects, which may cause damage, have been forgotten in or on the machine.
- Check that the equipment you are using for lifting or supporting parts of the machine, e.g. straps, slings, ratchet blocks and ground support, can safely cope with the strain they are exposed to and meet applicable regulations.
- Release the pressure in pressure vessels, components and systems carefully and in the prescribed way, so that the excess pressure is released without risk.
- When connecting hydraulic hoses, check that the desired effect has been achieved, that is, check that the hydraulic function operates in the expected way.
- Hoses, pipes and quick-connect couplings may be pressurized even if the machine is stationary and the engine turned "OFF." Such pipes and hoses should therefore only be disconnected by trained personnel.
- When looking for leaks, use a piece of paper or wood, not your hand.

## Fire Prevention Measures

There is always a risk of fire. It is important that you use a fire extinguisher that suits your machine and working environment and that you learn how to use it. The fire extinguisher must be placed behind the seat or externally in a lockable box.

If the machine is to be provided with a handheld fire extinguisher, it must be of the ABE type (ABC in the USA), which means that it is possible to extinguish fires in both solid and liquid carbonaceous material and that the active compound does not conduct electricity.

The effectiveness grade I means that the time the extinguisher is effective must not be less than eight seconds, grade II at least eleven seconds and grade III at least fifteen seconds.

A handheld fire extinguisher ABE I (in the USA ABC type) normally corresponds to a powder content of 4 kg (8.8 lb) (EN-grade 13A89BC), the EN 3-1995 standard, parts 1, 2, 4 and 5.

At the slightest sign of fire, and if the situation allows, take the following steps:

1. Drive the machine away from the fire sensitive area caused by the fire.
2. Lower the lifting arms to the ground.
3. Shut down engine by turning the ignition key to the "0" (OFF) position.
4. Leave the cabin.
5. Turn off the battery disconnect switch.
6. Start putting out the fire and notify the fire brigade/department if necessary.

It is forbidden to smoke or have an open flame near a machine when filling with fuel or when the fuel system has been opened and in contact with the surrounding air.

Diesel fuel oil is flammable and must not be used for cleaning. Use an approved solvent and do not inhale the fumes. Also bear in mind that certain solvents can cause skin rashes and constitute a fire hazard.

Flammable starting must not be used due to the use of the electric preheating in the induction air system.

Keep the place clean where the service is to be carried out. Oil or water makes the floor slippery and is also dangerous in connection with electrical equipment or electrically powered tools. Oily or greasy clothes are a serious fire hazard.

Check daily that the machine and the equipment, e.g. underbody plates are free from dust and oil. In this way the risk of fire is reduced and it is easier to detect faulty or loose components.

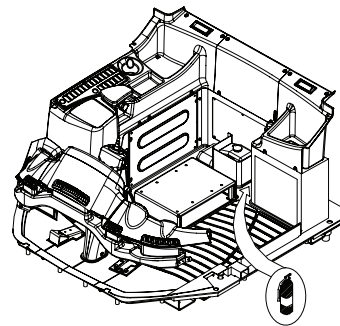

Figure 7

FG003902

**NOTE:** *If a high-pressure jet is used for cleaning, take great care as the insulation of electric leads can be damaged even at a moderately high-pressure and temperature. Protect electrical leads in an appropriate way.*

Take extra care when cleaning the machine after it has been used in a fire sensitive environment, e.g. sawmill and refuse dumps. Reduce the risk of spontaneous combustion by installing for example silencer guard or high capacity cyclone precleaner.

Sound absorbing material in the engine compartment must be kept clean to minimize the fire hazard.

Fire prevention equipment which is installed on the machine must be maintained and regarded as a complement to the actions of the operator in case of a fire.

Check that fuel lines, hydraulic and brake hoses and electrical cables have not been damaged by chafing or are not in danger of being damaged because of incorrect installation or clamping. This applies particularly to unfused cables, which are red and marked R(B+) and routed:

- between the batteries
- between battery and starter motor
- between alternator and starter motor
- to the preheating element on the engine.

Electrical cables must not lie directly against oil or fuel lines.

The following applies for welding and grinding work:

- A fire extinguisher must be kept near at hand.
- The ventilation must be good when working indoors.
- Approved respirator must be used
- The work surface must be cleaned.
- Do not weld or grind on components which are filled with flammable liquids, e.g. tanks and hydraulic pipes. Exercise care with such work in the proximity of these places.

## **Working on Painted Surfaces**

When welding, grinding and gas cutting, the paint finish must first be removed from an area with a radius of at least 10 cm (4 in) from the point where the work is to be carried out. The reason for this is that paint when heated gives off a great number of different substances which can cause irritation and be very harmful to a person's health in case of long or frequent exposure.

In addition to the health hazard, the weld will also be of an inferior quality and strength, which in the future may cause the weld to break. Therefore, never weld directly on a painted surface.

## **Methods and Precautionary Measures When Removing Paint:**

Blasting

- use respirator and eye protection

Paint remover or other chemicals

- use a portable air extractor, respirator and protective gloves

Grinding machine

- use a portable air extractor, respirator and protective gloves and eye protection

## **Floor Rubber**

Observe extra great care when it is suspected that you may have to handle floor rubber.

Certain seals which have to withstand high operating temperatures (e.g. in engines, transmissions, axles, hydraulic motors and pumps) may be made from floor rubber, which, when exposed to high heat (fire), forms hydrogen fluoride and hydrofluoric acid. This acid is very corrosive and cannot be rinsed or washed off from the skin. It causes very severe burns which take a long time to heal.

It usually means that damaged tissue must be surgically removed. Several hours may pass after contact with the acid, before any symptoms appear and therefore one is not given any immediate warning. The acid may remain on the machine parts for several years after a fire.

If swelling, redness or a stinging feeling appears and one suspects that the cause may be contact with heated floor rubber, contact a medical doctor immediately. If a machine, or part of a machine, has been exposed to fire or severe heat, it must be handled by specially trained personnel. In all handling of machines after a fire, thick rubber gloves and effective goggles must be used.

The area around a part which has been very hot and which may be made of floor rubber must be decontaminated by thorough and ample washing with lime water (a solution or suspension of calcium hydroxide, i.e. slaked lime in water). After the work has been completed, gloves must be washed in lime water and then discarded.

## Rubber and Plastics

Polymer materials when heated, can form compounds which are dangerous to health and environment and must therefore never be burned when scrapped. Also take care when handling machines which have been subjected to fire or other extreme heat.

If gas cutting or welding is to be carried out near such materials, the following safety instructions must be followed:

- Protect the material from heat.
- Use protective gloves, protective goggles and an approved respirator.

### Waste Hazardous to the Environment

Painted parts or parts made of plastic or rubber which are to be scrapped must never be burnt, but must be taken care of by an approved refuse handling plant.

Batteries, plastic objects and anything else which is suspected of being dangerous to the environment must be taken care of in an environmentally safe way.

### Check List After Fire

**When handling a machine which has been damaged by fire or been exposed to intense heat, the following protective measures must under all circumstances be followed:**

Use thick, gloves made of rubber and wear goggles which are certain to protect your eyes.

Never touch burnt components with your bare hands, as there is a risk that you may come into contact with melted polymer materials. First wash thoroughly with plenty of lime water (a solution or suspension of calcium hydroxide, i.e. slaked lime in water).

As a precaution, seals (O-rings and other oil seals) should always be handled as if they were made of floor rubber.

Treat skin, which is suspected of having come into contact with burnt floor rubber, with Hydrofluoric Acid Burn Jelly or something similar. Seek medical advice. Symptom may not appear until several hours afterwards.

Discard gloves, rags etc. which are suspected of having come into contact with burnt floor rubber.

# PREVENTIVE MAINTENANCE

Periodic checks and replacement of oil, grease, filters, etc. must be made at specific intervals, to keep machine in good working condition. The following pages describe items to be checked, lubricants to be used, and time interval between each check.

**NOTE:** *Time interval between each service check may need to be shortened if machine is operating in severe atmospheric conditions. Machines working in extremely hot or dusty conditions will require more frequent service checks. Total hours of machine operation are determined by hour meter that is on the front instrument panel.*

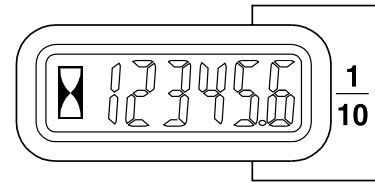

Figure 8

HAOA600L

## Product Identification Number (P. I. N.) Location

The PIN is stamped on the product identification plate (Figure 9) on the right side of front frame above wheel cover.

**NOTE:** *Please make note of these numbers and their locations. These will be required whenever warranty or service work is requested. Keep this number on file, in case the machine is stolen.*

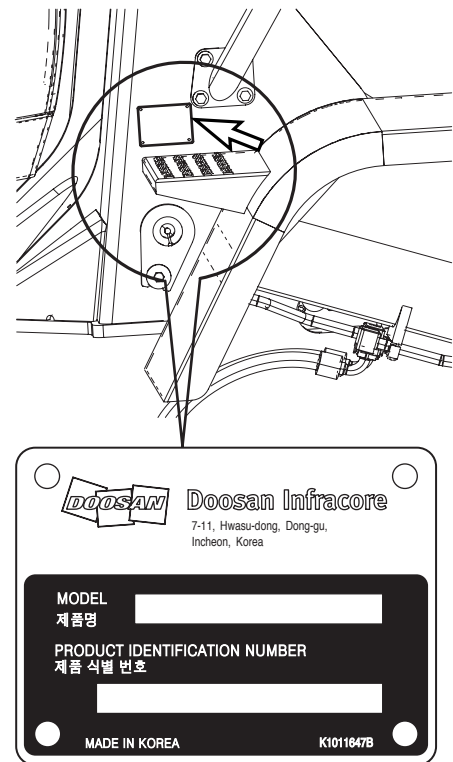
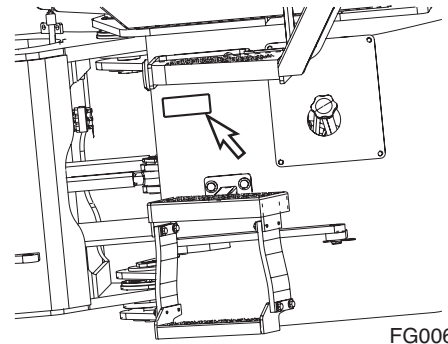

Figure 9

FG008837

The number is also stamped in the rear frame on the left side just below the cabin (Figure 10).



FG006230

Figure 10

### Engine Serial Number

The engine name plate (identification label) is attached to engine headcover (Figure11 , 1). The engine serial number is stamped on the right rear of the engine block, under exhaust manifold (Figure11 , 2).

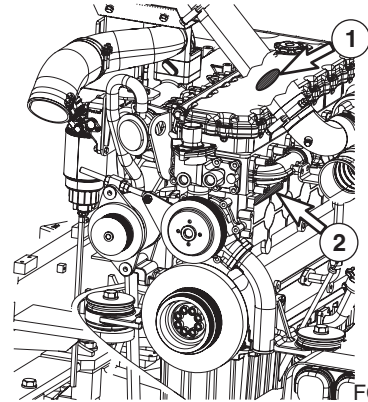

FG006234

Figure 11

### Safety Precautions

1. Before performing any maintenance checks, move pilot cutoff switch to "LOCKED" position. Place a Warning Tag on controls so that no one begins to operate machine while maintenance checks are being performed.
2. Clean up all fuel spills. Fuel spills are hazardous, especially around engine.
3. Inspect all fuel lines for leakage. Replace any lines, fittings, O-rings, or filters that show signs of wear or damage.
4. If a test procedure requires engine to be running, use two people and keep all unnecessary personnel away from machine.

# TABLE OF RECOMMENDED LUBRICANTS

## IMPORTANT

Do not use lubricants other than those recommended, without prior written approval from **DOOSAN**.

**NOTE:** Refer to the Maintenance Intervals Table for application points.

LUBRICANT MANUFACTURER	HYDRAULIC OIL	ENGINE OIL	LUBRICANT GREASE	GEAR OIL
TOTAL	TOTAL EQUIVIS ZS 46 IV	TOTAL RUBIA TIR 7400 10W40 TOTAL RUBIA POLYTRAFIC 10W40 TOTAL RUBIA 8600 10W40	TOTAL MULTIS EP #2	
GS-CALTEX	RANDO HD CZ 46	SIGMA DX-1 10W40	MULTIFAK EP #2	
CHEVRON	AW 32 (BELOW 0°C) AW 46 (ABOVE 0°C)	DELO 400 15W40	DELO GREASE EP #2	
TEXACO	RANDO HDZ 46	URSA SUPER PREMIUM 15W40	MULTIFAK ALL PURPOSE EP #2	
ESSO	UNIVIS N 46	ESSOLUBE XT-5 15W40	RONEX MP	
MOBIL	MOBIL DTE 13M	MOBIL DELVAC MX 15W40	RONEX MP	MOBILFLUID 424 ESSO TORQUE FLUID 56 MOBIL AGRIFLUID 424 MOBIL FLUID 426 MOBILFLUID 2040
SHELL	TELLUS OIL T 46	RIMULA ULTRA 10W40	ALVANIA EP #2	ASEOL MULTITRAC 85W
PENNZOIL	-	-	PENNZOIL MULTIPURPOSE WHITE GREASE 705 EP #2	

LUBRICANT MANUFACTURER	HYDRAULIC OIL	ENGINE OIL	LUBRICANT GREASE	GEAR OIL
CASTROL	PARADENE AW 32 (BELOW 0°C) PARADENE AW 46 (ABOVE 0°C)	-	CASTROL EPL #2	KOMATSU WBL 20W40
IDEMITSU KOSAN	DAPHNE KOSAN 32 WR (BELOW 0°C) DAPHNE KOSAN 46 WR (ABOVE 0°C)	-	DAPHNE EXPONES SR #2	-

LUBRICANT MANUFACTURER	TRANSMISSION GEAR OIL
Same as engine oil	SAE 15W40 API CD and above

Antifreeze	
Recommended Concentration	Manufacturers Meeting ASTM D3306
50% Antifreeze - 50% Distilled Water	Dexcool ELC by Chevron Texaco
	Alugard G48 by BASF
	Others meeting or exceeding ASTM D3306



## CAUTION!

Do not mix oils from different manufacturers. *DOOSAN* does not endorse specific brands but does suggest that owners select quality oils whose suppliers provide assurance that required standards will always be met or exceeded.

## IMPORTANT

Fluctuating daily or weekly extremes of temperature, or operation in subzero freezing weather may make it impractical to use straight weight lubricants. Use good judgement in selecting lubricant types that are appropriate for climate conditions.

# AXLE OILS DL400, DL300, DL250

## Oil Grade Mobile Fluid 424

Oil intended for axles with built-in brakes

### Requirements

Property	Unit	Mobil fluid 424	Test method
Density	kg/l, @15°C	0.884	ASTM D 4052
Flash Point	°C	198	ASTM D 92
Pour Point	°C	-42	ASTM D 97
Viscosity at 40°C	mm <sup>2</sup> /s (cSt)	55	ASTM D 445
Viscosity at 100°C	mm <sup>2</sup> /s (cSt)	9.3	ASTM D 445
Rust Protection 24h		No rust	ASTM D 665A
API Class		GL-4	ASTM STP-512A
Brokfield Viscosity	cp (@-35C)	55,000	
Viscosity Index		145	ASTM D 2270

Examples of oils which meet the requirements according to the table on the next page.

## Axle Oils for DL400, DL300, DL250

Examples of oils which meet the requirements according to the table on the previous page.

### Lubricant Class 05E

Viscosity grades: SAE 20W-40 / 80W-140

Oil Company	Trade Name
CASTROL INTERNATIONAL, PANGBOURNE READING/GB	KOMATSU WBL 20W40
CNH, BURR RIDGE/USA	CASE TRANSAXLE FLUID, SAE 80W-140
EXXON MOBIL CORPORATION, FAIRFAX, VIRGINIA/USA	MOBILFLUID 2040
FUCHS PETROLUB AG, MANNHEIM/D	TITAN HYDRA ZF 20W-40
MAZIVA ZAGREB D.O.O. ZAGREB/HR	INA TRASHIDROL ZF 20W-40
OMV AG, SCHWECHAT/A	MOV AUSTROMATIC ZF SAE 20W-40
PAKELO MOTOR OIL S.R.L., SAN BONIFACIO (VR)/I	PAKELO UTTO FLUID 4D SAE 20W-40
STRUB + CO AG, REIDEN/CH	VULCOTRAC UTTO SAE 20W-40

### Lubricant Class 05F

Oil Company	Trade Name
76 LUBRICANTS COMPANY, COSTA MESA/USA	76 HYDRAULIC/TRACTOR FLUID
ARAL AG, BOCHUM/D	ARAL FLUID HGS SAE 80W
AVIA MINERALOL-AG, MUNCHEN/D	AVIA HYDROFLUID DLZ
BP INTERNATIONAL, PANGBOURNE, READING/GB	BP OLEX GO 4926
BP INTERNATIONAL, PANGBOURNE, READING/GB	BP TERRAC SUPER TRANSMISSION
BP INTERNATIONAL, PANGBOURNE, READING/GB	BP TRACTRAN TF 10
BUCHER AG LANGENTHAL, LANGENTHAL/CH	MOTOREX POLYFARM 304
CASTROL INTERNATIONAL, PANGBOURNE READING/GB	CASTROL AGRI POWERTRANS 10W-30
CASTROL INTERNATIONAL, PANGBOURNE READING/GB	CASTROL AGRI TRANS PLUS 10W-30
CASTROL INTERNATIONAL, PANGBOURNE READING/GB	CASTROL KOMATSU UTTO 10W-30
CATERPILLAR INC., PEORIA/USA	CATERPILLAR MULTIPURPOSE TRACTOR OIL (MTO) 10W-30
ENGEN PETROLEUM LTD., CAPE TOWN/ZA	ENGEN AGRIFLUID
ENI S.P.A. REFINING and MARKETING DIVISION, ROME/I	ROTRA JD/F
EXXON MOBIL CORPORATION, FAIRFAX, VIRGINIA/USA	ESSO TORQUE FUID 56
EXXON MOBIL CORPORATION, FAIRFAX, VIRGINIA/USA	MOBIL AGRIFLUID 424

Oil Company	Trade Name
EXXON MOBIL CORPORATION, FAIRFAX, VIRGINIA/USA	MOBIL FLUID 424
EXXON MOBIL CORPORATION, FAIRFAX, VIRGINIA/USA	MOBIL FLUID 426
FLITALIA S.P.A., VILLASTELLONE/I	AMBRA MULTI G
FUCHS PETROLUB AG, MANNHEIM/D	TITAN HYDRA J20C
GINOUVES GEORGES SA, LA FARLEDE/F	YORK 676 SAE 10W30
IGOL FRANCE SA, AMIENS/F	TICMA FLUID MU SAE 80W
JOHN DEERE, MANNHEIM/D	JOHN DEERE HY-GARD
KENDALL MOTOR OIL, COSTA MESA/USA	KENDALL HYKEN 052
KUWAIT PETROLEUM RandT B.V., EUROPOORT RT/NL	Q8 T 2000
KUWAIT PETROLEUM RandT B.V., EUROPOORT RT/NL	Q8 T 2200
OEL-BRACK AG, HUNZENSCHWIL/CH	MIDLAND TOU
OMV AG, SCHWECHAT/A	OMV AUSTROMATIC IGB SAE 10W-30
PAKELO MOTOR OIL S.R.L, SAN BONIFACIO (VR)/I	PAKELO UTTO FLUID 4D SAE 10W/30
PANOLIN AG, MADETSWIL/CH	PANOLIN JD 303
PETROGAL S.A., LISBOA/P	GALP TRALUB 807S
REPSOL LUBRICANTES, MADRID/E	AGRO ORION SAE 10W30
SHELL ASEOL AG, BERN 5/CH	ASEOL MULTITRAC 85W
SRS SCHMIERSTOFF VERTRIEB GMBH, SALZBERGEN/D	WINTERSHALL HYDROFLUID N

#### Lubricant Class 05G

Oil Company	Trade Name
CATERPILLAR INC., PEORIA/USA JOHN DEERE, MANNHEIM/D ZF FRIEDRICHSHAFEN AG, FRIEDRICHSHAFEN/D	CATERPILLAR MULTIPURPOSE TRACTOR OIL(MTO) JOHN DEERE HY-GARD ZF-POWERFLUID

## DL06 Industrial Engines Oil Drain Intervals by Duty Cycle (Hours)

	Heavy
ACEA E5 (API CI-4) CES 20078	500
<p><b>NOTE:</b></p> <ol style="list-style-type: none"> <li>Limit oil change interval to 250 hour maximum for oil grades if 40% of the operating time is in ambient temperatures above 38°C (100°F) to prevent engine damage to oil degradation resulting from high oil temperature.</li> <li>We don't recommend the use of CF or CG grade oils. If CF or CG oils must be used, make the oil drain intervals half of the API CI-4 values.</li> <li>Engine oil drain intervals need to be reduced by 50% when fuel sulfur content exceeds 0.5% (5000 ppm).</li> </ol>	

## FLUID CAPACITIES

Component		Capacity
Engine		DL 06
Engine	Oil Pan with Filter	27 liters (7.1 U.S. gal.)
	Cooling System	45 liters (11.9 U.S. gal.)
Fuel Tank		255 liters (67 U.S. gal.)
Hydraulic Oil Tank		158 liters (42 U.S. gal.)
Transmission		45 liters (11.9 U.S. gal.)
Axles	Front Axle	31 liters (8.2 U.S. gal.)
	Rear Axle	24 liters (6.3 U.S. gal.)

# LUBRICATION AND SERVICE CHART

## Greasing Bearing

The service life of bushings and pivot pins can be extended considerably, if the machine is greased regularly and in the correct way.

The greasing of bearings has two main purposes:

- Add grease to the bearing to reduce friction between pin and bushing.
- Replace old grease which may contain dirt. The grease in the space inside the outer seal collects dirt and prevents dirt and also water from penetrating into the bearing.







Therefore, grease the bearing until new, clean grease is forced out through the outer seal.







Between 10 and 15 strokes with a normal handheld grease gun is required to grease one of the bearings for the lifting arms.

Wipe off grease fittings and grease gun before greasing, so that dirt and sand is not introduced through the grease fittings.

## Symbol key

These standard symbols are used in “Lubrication and Service Chart” on page 4-22.

Symbol	Description
	Lubrication
	Transmission Oil
	Engine Oil
	Engine Oil Filter
	Hydraulic Oil
	Hydraulic Oil Return Filter
	Coolant

Symbol	Description
	Air Cleaner Element
	Fuel Filter
	Air Conditioner Filter
	Drain Water
	Gear Oil (Axles)
	Brake Filter
	Level Check

# Lubrication and Service Chart

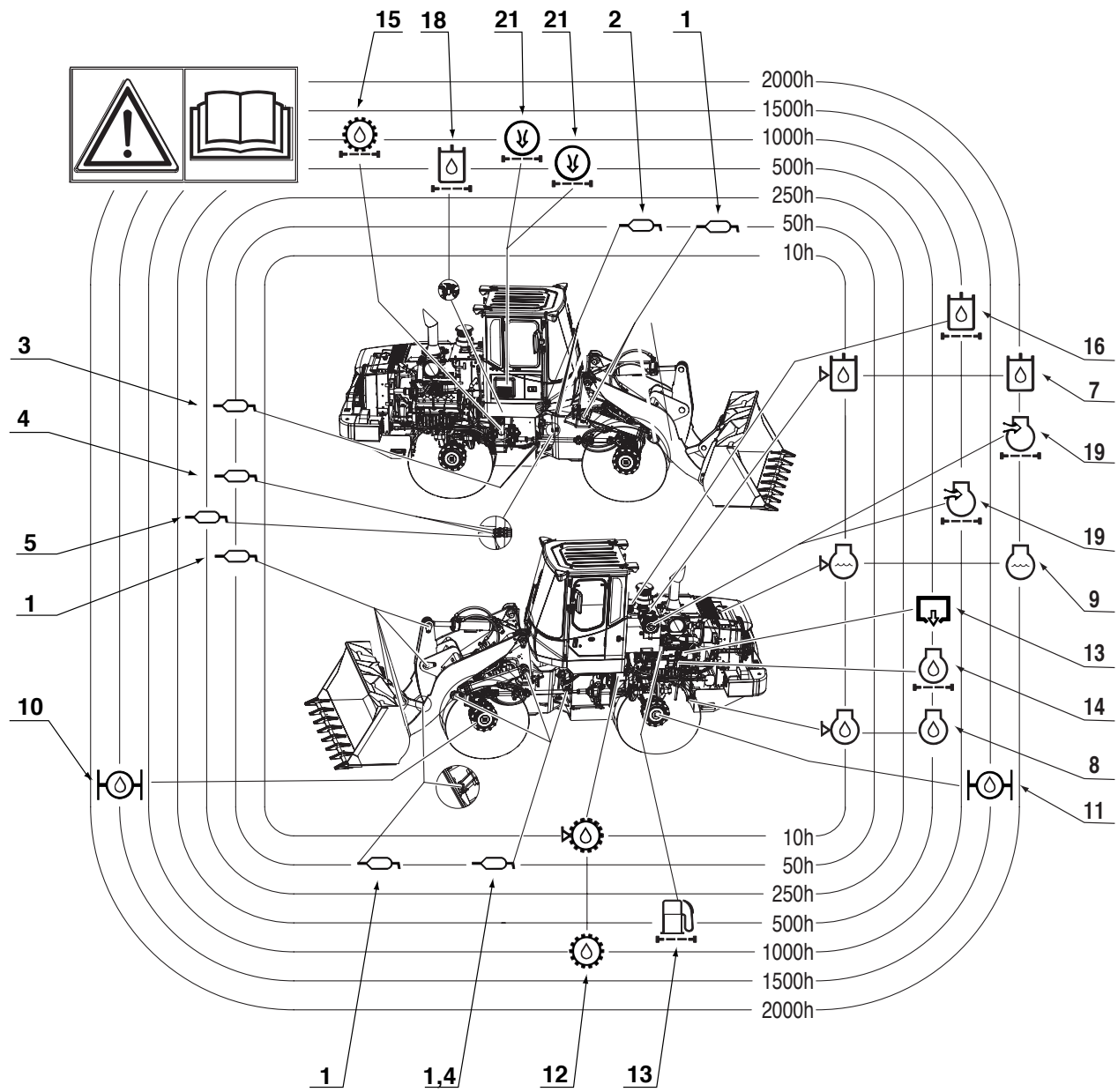

FG008507

Figure 12

Service Data										
No.	Items To Check		Service	Qty.	Service Interval					
					10	50	250	500	1000	1500
1	Front Joint Pin		Grease	13	F100					
2	Articulation Pin		Grease	2						
3	Rear Axle Pivot		Grease	3						
4	Steering Cylinder		Grease	4						
5	Front Drive Shaft Bearing		Grease	1						
6	Fuel Tank		Diesel	255 L	V					
7	Hydraulic Oil Tank		Hydraulic Oil	158 L	V					
8	Engine Oil Pan		Engine Oil 15W40	27 L	V	F				
9	Radiator		Coolant (Antifreeze)	45 L	V					PG
10	Front Axle		Axle Gear Oil (80W90)	31 L			F			
11	Rear Axle		Axle Gear Oil (80W90)	24 L			F			
12	Transmission		Engine Oil 15W40	45 L	V		F			
13	Fuel Filter	Pre	Cartridge	1						
		Main		1						
14	Engine Oil Filter		Cartridge	1		F				
15	Transmission Filter		Cartridge	1			F			
16	Full Flow Filter		Element	1		F				
17	Oil Suction Strainer		Strainer	1						C
18	Brake and Pilot Filter		Element	1						
19	Air Cleaner		Element (Outer)	1			C			
			Element (Inner)	1						
20	Air Intake Precleaner		Case	1			C			
21	Air Conditioner Filter	Outer	Cartridge	1		C				
		Inner		1			C			
<b>V:</b> Maintenance and Refill.										
<b>C:</b> Cleaning.										
<b>F:</b> First Time Exchange Only.										
<b>F100:</b> Every 10 Hours for First 100 Hours.										
<b>W10:</b> Every 10 Hours If Operating In Water.										
<b>EG:</b> Ethylene Glycol - Standard Life Antifreeze (Drain and replace using this interval.) See "Engine Cooling System" on page 4-75, for further explanation.										
<b>PG:</b> Propylene Glycol - Extended Life Antifreeze (Drain and replace using this interval.) See "Engine Cooling System" on page 4-75, for further explanation.										
<b>Gray Box:</b> Replacement On Every Interval.										
<b>NOTE:</b> For additional service items see list of "Maintenance Intervals" on page 4-24.										

# MAINTENANCE INTERVALS

SERVICE ITEM	PAGE
<b>10 Hour / Daily Service</b>	
Grease Front Attachment Pins (for First 100 Hours)	4-26
Inspect All Tires for Correct Tire Pressure and Signs of Damage or Abnormal Wear	4-26
Check Engine Oil Level	4-26
Check Transmission Oil Level Sight Gauge	4-27
Check Hydraulic System Oil Level	4-28
Check for Leaks in Hydraulic System	4-29
Fill Fuel Tank	4-29
Check for Leaks in Fuel System	4-30
Drain Fuel Condensation	4-30
Check Coolant Level	4-30
Check Level of Windshield Washer Liquid	4-31
Inspect the Bucket Teeth and Side Cutters for Signs of Wear	4-31
Inspect Seat Belt for Proper Operation	4-31
Inspect the Structure for Cracks and Faulty Welds	4-31
Check the Operation of All Switches	4-31
Check the Operation of All Exterior Lights, Horn and Control Console Indicator and Monitor Lights	4-32
Start Engine, Check Starting Ability, and Observe Exhaust Color at Start-up and at Normal Operating Temperature. Listen for Any Abnormal Sounds	4-32
Check Operation of All Controls	4-32
Inspect Cooling Fan Blade	4-33
Check Engine Drive Belt Wear	4-33
Check Air Intake System	4-34
<b>50 Hour / Weekly Service</b>	
Perform All Daily, 10 Hour Service Checks	4-35
Grease Front Attachment Pins	4-35
Grease Steering Cylinder Rod and Head Ends	4-38
Grease Upper and Lower Center Pins	4-39
Replace Engine Oil and Filter (After First 50 Hours)	4-39
Replace Hydraulic Full Flow Filter (After First 50 Hours)	4-39
Check Air Conditioner and Alternator Belt Tension (After First 50 Hours)	4-39
Clean Exterior of Radiator, Oil Cooler and Air Conditioner Condenser	4-40
Clean Air Conditioner Outer Filter	4-40
<b>250 Hour / Monthly Service</b>	
Perform All Daily 10 Hour and 50 Hour Service Checks	4-41
Check Engine Air Intake Precleaner	4-41
Drain Water From Hydraulic Oil Tank	4-41
Turbocharger	4-42
Check Air Conditioner and Alternator Belt Tension	4-42
Grease Drive Shafts	4-43

Transmission Oil and Filter (After First 250 Hours)	4-43
Clean Outer Filter of Air Cleaner	4-44
Water Trap	4-45
<b>500 Hour / 3 Month Service</b>	
Perform All Daily, 10, 50 and 250 Hour Service Checks	4-46
Replace Hydraulic System Brake and Pilot Filter	4-46
Replace Fuel Prefilter	4-47
Fuel Filter (Spin-On Type)	4-48
Replace Fuel Filter	4-49
Clean Exterior of Radiator, Oil Cooler and Air Conditioner Condenser	4-49
Clean Inner Air Conditioner Filter	4-50
Replace Axle Differential and Planetaries Oil Replacement (After First 500 Hours)	4-50
Replace Engine Oil and Filter	4-51
Replace Air Conditioner Outer Filter	4-52
<b>1,000 Hour / 6 Month Service</b>	
Perform All Daily 10, 50, 250 and 500 Hour Service Checks	4-53
Air Cleaner	4-53
Replace Outer Air Cleaner Element	4-54
Drain and Replace Transmission Oil and Filter	4-55
Clean Fuel Tank and Strainer	4-57
Replace Inner Air Conditioner Filter	4-58
Check Air Conditioner Refrigerant	4-58
Check and Adjust Engine	4-59
Replace Hydraulic Full Flow Filter	4-60
<b>1,500 Hour / 9 Month Service</b>	
Perform All Daily 10, 50, 250 and 500 Hour Service Checks	4-61
Replace Axle Differential and Planetaries Oil	4-61
Axle Brake Disk Wear Measurement	4-63
<b>2,000 Hour / Yearly Service</b>	
Perform All Daily, 10, 50, 250, 500 and 1,000 Hour Service Checks	4-64
Replace Inner Air Cleaner Element	4-64
Check Steering, Brake, Drive Shaft, Engine, and Fuel System	4-64
Replace Pipes and Hoses	4-64
Bleed Brakes	4-65
Replace Radiator Coolant	4-66
Replace Hydraulic Oil and Clean Oil Suction Strainer	4-67
Check Brake Accumulator	4-69
<b>12,000 Hour / Six Year Service</b>	
Hose In-service Lifetime Limit (European Standard ISO 8331 and EN982 CEN)	4-70

# 10 HOUR / DAILY SERVICE

## Grease Front Attachment Pins (for First 100 Hours)

**NOTE:** *Fittings are greased daily, or every 10 hours, for the first 100 hours of operation to comply with new machine break-in requirements. After that, greasing must be done every 50 hours. If bucket is being used in water, grease fittings immediately after machine is removed from water. Follow procedure printed under the 50 hour maintenance interval "Grease Front Attachment Pins" on page 4-35.*

## Inspect All Tires for Correct Tire Pressure and Signs of Damage or Abnormal Wear

1. Inflate tires to proper operating pressure for working conditions. See "Tires" on page 4-86

## Check Engine Oil Level

**NOTE:** *When checking level using a dipstick always remove and wipe it clean before making final level check.*

1. Check level of engine oil every day before starting engine.

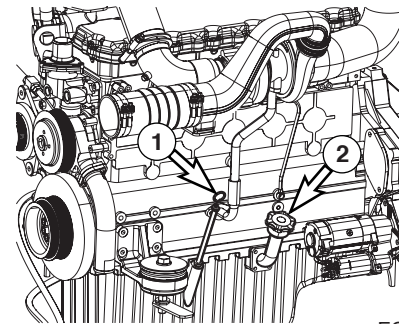

FG006238

Figure 13

2. Remove engine oil dipstick (Figure 13, 1). Oil level must be between "LOW" and "FULL" marks.

**NOTE:** *If oil is above "HIGH" mark on dipstick, some must be drained to return oil to proper level.*

3. To add oil, remove engine oil fill cap (Figure 13, 2).

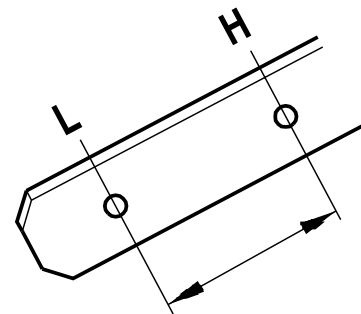

HAOC280L

Figure 14

## Check Transmission Oil Level Sight Gauge

1. Use two people to perform this operation.
2. Start machine and drive it until transmission fluid has warmed to 80°C (176°F). Park machine on firm, level ground. Lower bucket to ground.
3. Place transmission lever in "NEUTRAL." Apply parking brake. Shut down engine.
4. Block tires. Once tires are blocked, start engine and have a person remain in the cabin.
5. With engine running, have second person, find transmission oil level sight gauge (1, Figure 16) on transmission fill tube (2).
6. Oil level must be at "HOT" mark or above as shown in (Figure 16).

**NOTE:** If oil level is above top end of sight gauge (completely filling it), drain oil until level is at "HOT" mark.

**NOTE:** If transmission cannot reach an operating temperature of 80°C (176°F), then the oil level must be visible in the sight gauge below the "HOT" mark. Periodically check oil level during the workday to ensure that oil level does not rise above top end of sight gauge.

7. To add oil, remove transmission fill cap (Figure 15) from transmission oil fill pipe. Refer to "Table of Recommended Lubricants" on page 4-14, of this manual for recommended oil for the operating conditions.
8. Shut down engine when done.

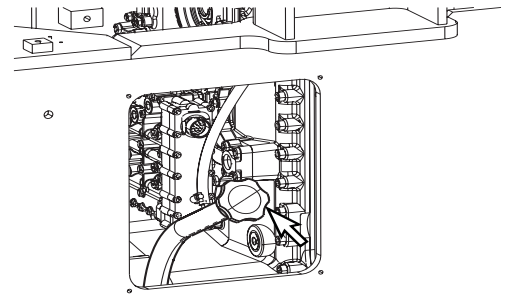

Figure 15

FG006242

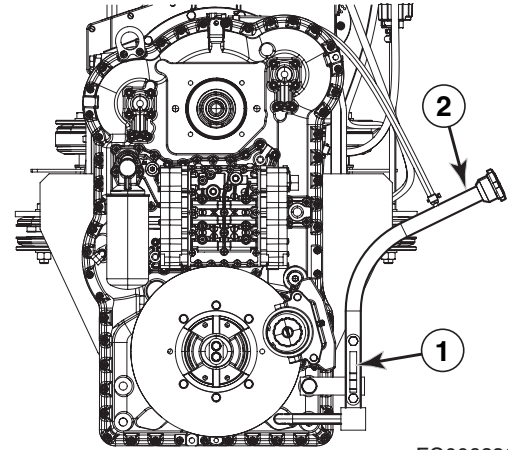

Figure 16

FG006236

1. TRANSMISSION SIGHT GAUGE
2. TRANSMISSION FILL TUBE

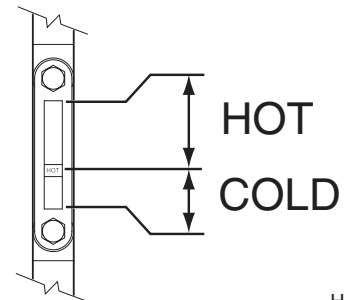

Figure 17

HAAD4540

TRANSMISSION SIGHT GAUGE

## Check Hydraulic System Oil Level

### **WARNING!**

The hydraulic oil will be hot after normal machine operation. Allow system to cool before attempting to service any of the hydraulic components.

The hydraulic tank is pressurized. Turn breather cap slowly to allow pressurized air to vent. After the pressure has been released, it is safe to remove either the fill cap or service covers.

1. Move machine to a level area and shut down engine.
2. Apply parking brake.
3. Lower bucket to ground.
4. Check sight gauge that is attached to hydraulic tank. Oil level must be visible in red centered circle shown on sight gauge (1, Figure 19).

5. To add hydraulic oil, turn breather cap (1, Figure 20) slowly to allow pressurized air to vent.
6. Remove upper cover (2, Figure 20) from hydraulic oil tank and raise boom at max. height and replenish oil to the top of sight gauge (Figure 19).

### **IMPORTANT**

**Do not fill above red centered circle on sight gauge. Overfilling can result in damage to equipment and oil leaking from hydraulic tank due to expansion.**

The hydraulic oil fill cover also serves as the hydraulic oil strainer access cover. It is important to replace this cover and the components in the proper order and alignment.

The filter (2, Figure 21), retaining rod (3) and spring (4) are assembled as shown in Figure 21. The hole (1) in the base of the filter fits over a circular base in the bottom of the tank. The retaining rod (3) screws into the top of the filter (2), but the spring (4) slides over the top of the rod. Be certain that this spring does not fall into the tank during reassembly.

1. If filter assembly was removed, insert assembly into the tank and check to make sure it is securely in place.



HAOA060L

Figure 18

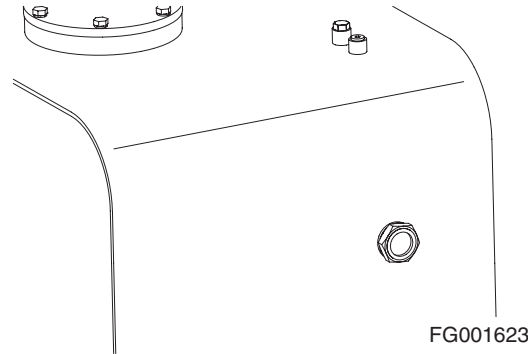

Figure 19

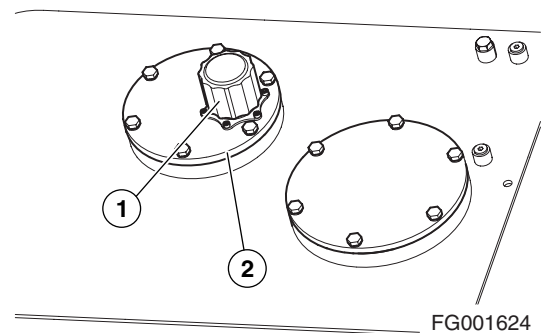
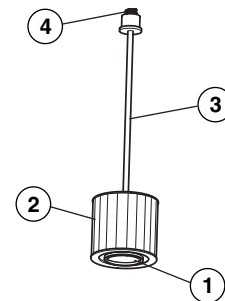

Figure 20



FG002188

Figure 21

2. Check O-ring for damages and replace if necessary. Check position of O-ring at surface of hole.
3. Place the cover on the access hole. Make sure the spring retaining cup (1, Figure 22) in the lower section of the cover is lined up with the spring. The filter assembly rod must be in a vertical position and perpendicular to the base of the tank. The cover can be rotated to align the rod into a vertical position.
4. Tighten mounting bolts to 4.84 kg•m (35 ft lb).

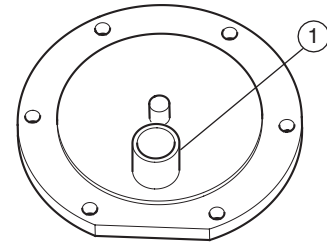

FG002189

Figure 22

## Check for Leaks in Hydraulic System

1. Perform a daily walk-around inspection to make sure that the hoses, piping, fittings, cylinders and hydraulic motors are not showing any signs of leakage. If any is noted, determine the source of the leak and repair.

## Fill Fuel Tank



### WARNING!

Use extreme safety precautions while refueling to prevent explosions or fire.

Immediately clean up any spilt fuel.

1. At end of each work day, fill fuel tank. Add fuel through fuel fill cap (Figure 23). When working at a temperature of 0°C (32°F) or higher, use ASTM No. 2-D or its equivalent. At temperatures below 0°C (32°F) use ASTM No. 1-D or its equivalent.
2. Securely tighten cap after fueling.

**NOTE:** *If breather holes in cap are clogged, a vacuum may form in the tank preventing proper fuel flow to engine. Keep holes in fuel cap clean.*

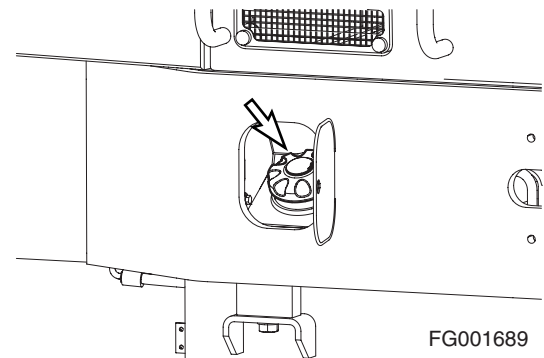

FG001689

Figure 23

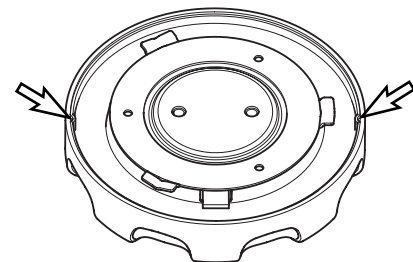

FG001690

Figure 24

## Check for Leaks in Fuel System

1. Perform an inspection of engine compartment to verify that fuel system is not leaking. If any is noted, determine the source of leak and repair.

## Drain Fuel Condensation

1. Open fuel tank drain valve. (Figure 25). Allow any condensed water or sediment to drain out of tank.

**NOTE:** *Dispose of drained fluids according to local regulations.*

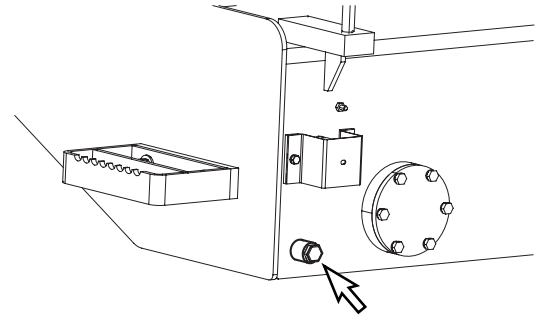

FG006245

Figure 25

## Check Coolant Level

**NOTE:** *Do not mix ethylene glycol and propylene glycol antifreeze together. If the two are mixed, the protection level will be reduced to the level of the ethylene glycol.*

**NOTE:** *This unit was factory filled with propylene glycol.*



## WARNING!

**Never open radiator when it is hot. Scalding liquid inside a hot radiator is under pressure. Removing cap from a hot radiator could cause a person to be sprayed and burned from liquid inside. Wait for radiator temperature to cool down before removing cap.**

1. Check sight gauge (1, Figure 27) that is attached to the radiator. Coolant level must be visible in red centered circle shown on gauge. To add coolant, remove fill cap (2, Figure 27) of the radiator and add coolant to proper level by checking sight gauge (1, Figure 27). If temperature is below freezing, see “Antifreeze Concentration Tables” on page 4-76 for antifreeze protection. Use the table to calculate a proper mixture of antifreeze and water to provide level of protection necessary for expected temperature.

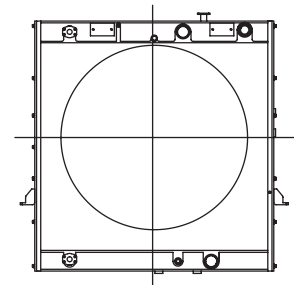

FG001692

Figure 26

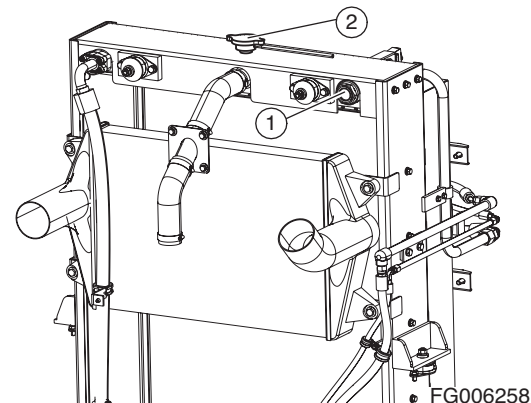

FG006258

Figure 27

## Check Level of Windshield Washer Liquid

1. Check fluid level in windshield washer tank, behind operator's seat.
2. Open fill cap and add fluid.

**NOTE:** Use a washer liquid that is rated for all seasons. This will prevent freezing during cold weather operation.

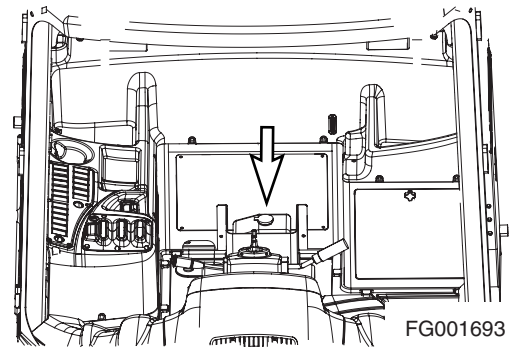

Figure 28

FG001693

## Inspect the Bucket Teeth and Side Cutters for Signs of Wear

1. On a daily basis, inspect bucket teeth to make sure that tooth wear or breakage has not developed.
2. Do not allow replaceable bucket teeth to wear down to the point that base edge is exposed. (Figure 31)

**NOTE:** These instructions are only for DOOSAN OEM buckets. If you are using other manufacturers' buckets, refer to their specific instructions.

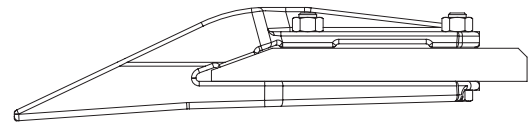

Figure 29

FG007021

## Inspect Seat Belt for Proper Operation

## Inspect the Structure for Cracks and Faulty Welds

1. During the daily walk-around inspection and when greasing the machine, look for any visible damage to the machine. Repair or replace any damaged parts before operating machine.

## Check the Operation of All Switches

1. Verify working condition of all switches before starting engine.

## **Check the Operation of All Exterior Lights, Horn and Control Console Indicator and Monitor Lights**

1. Turn engine starter switch to "I" (ON) position and observe all indicator lights.
2. Restore operation of any light bulbs that do not turn "ON" at this time.
3. Sound the horn. Repair or replace if required.
4. Turn "ON" and inspect all exterior work lights. Replace any monitors, burned out bulbs or cracked or broken housings or lenses.

## **Start Engine, Check Starting Ability, and Observe Exhaust Color at Start-up and at Normal Operating Temperature. Listen for Any Abnormal Sounds**

### **Check Operation of All Controls**

---

## **IMPORTANT**

---

**Cold weather operation requires that the operator fully warm up the hydraulic oil before beginning machine operation. Follow all warm up instructions listed in the Operating Instruction section of this manual. Make sure to cycle oil through all of the components, including all cylinders, both travel motors and the swing motor. Cold hydraulic oil in the lines and components needs to be warmed before beginning full operation. If this is not done, damage to the cylinders or hydraulic motors can occur.**

---

1. With engine at rated speed, operate all of the controls.
2. Follow cold weather hydraulic system warm-up procedures.
3. Note any slow operations or unusual movements. Determine the cause and repair fault before operating.

## Inspect Cooling Fan Blade



### WARNING!

Personal injury can result from a fan blade failure. Never pull or pry on the fan. This can damage the fan blade(s) and cause fan failure.

1. An inspection of the cooling fan is required daily. Check for cracks, loose rivets, bent or loose blades, and for contact between the blade tips and the fan shroud. Check the fan to make sure it is securely mounted. Tighten the bolts if necessary. Replace any fan that is damage.

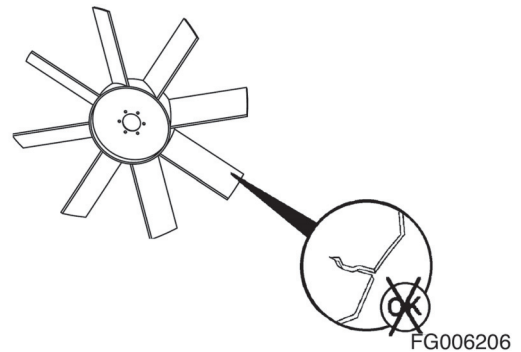

Figure 30

## Check Engine Drive Belt Wear



### WARNING!

Keep clear of engine fan and fan drive belts when the engine is running. Rotating fan and belt contact can cause injury.



### WARNING!

When checking, adjusting or replacing drive belts, care must be taken to prevent accidental cranking of the engine. Be sure the starter switch is in the "O" (OFF) position and the controls are tagged.

1. Replace badly worn, greasy or severely cracked belts immediately. These conditions prevent proper belt function. Visually inspect the belt. Check the belt for intersecting cracks. Transverse (across the belt width) cracks are acceptable. Longitudinal (direction of belt length) cracks that intersect with transverse cracks are not acceptable. Replace the belt if it is frayed or has pieces of material missing.
2. Before installing new belts, make sure all pulley grooves are clean and not worn. Replace pulley, if damaged, or if the grooves are worn.
3. All pulley support bearings, shafts, and brackets must be in working order.
4. When replacing belts and pulleys, pulley alignment must be checked with belts tensioned and brackets securely clamped. A misalignment that can be detected by the naked eye is detrimental to belt performance.

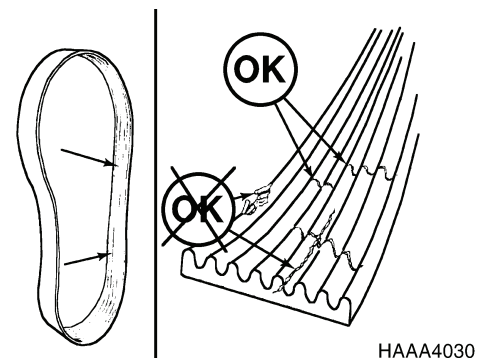

Figure 31

5. Do not force the belts into the pulley grooves by prying with a screwdriver or pry bar. This will damage the belt side cords which will cause the belts to turn and result in complete destruction of the belts in operation.
6. Belts on new machines and replacement belts lose their tension as they seat into the pulley grooves. Check the tension of new belts at 20 hour intervals until tension is stabilized and thereafter, every 250 hours. If the tension falls below the required minimum, the belt will be able to slip, damaging the belts and pulley grooves.

**NOTE:** *When operating in abrasive conditions, check tension every 100 hours.*

## Check Air Intake System



**Hot engine components can cause burns.**

**Avoid contact with hot engine components.**

---

1. Park the machine on a level surface, apply the parking brake, lower the attachment to the ground, and shut down engine.
2. Check the engine intake hose, and hose clamps for damage and tightness.
3. If damaged, wrinkled or loose, replace, tighten or contact your nearest *DOOSAN* loader dealer.

---

## IMPORTANT

---

**Severe engine damage will result from running with unfiltered air.**

**Do not operate engine if any leaks or defects are found on air intake system.**

---

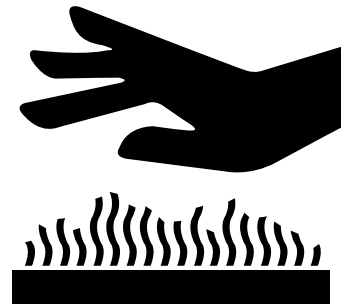

HAOA050L

**Figure 32**

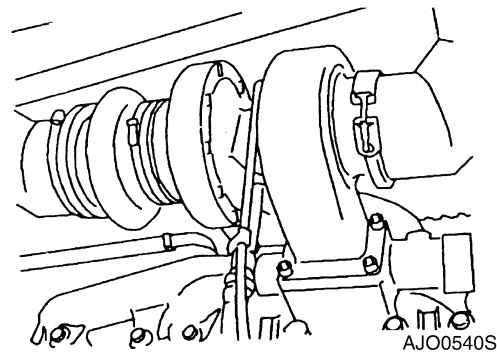

AJO0540S

**Figure 33**

# 50 HOUR / WEEKLY SERVICE

## Perform All Daily, 10 Hour Service Checks

### Grease Front Attachment Pins

1. Following fittings are greased daily, or every 10 hours, for first 100 hours of operation to comply with new machine break-in requirements. After that, greasing must be done every 50 hours. If bucket is being used in water, grease fittings immediately after machine is removed from water.

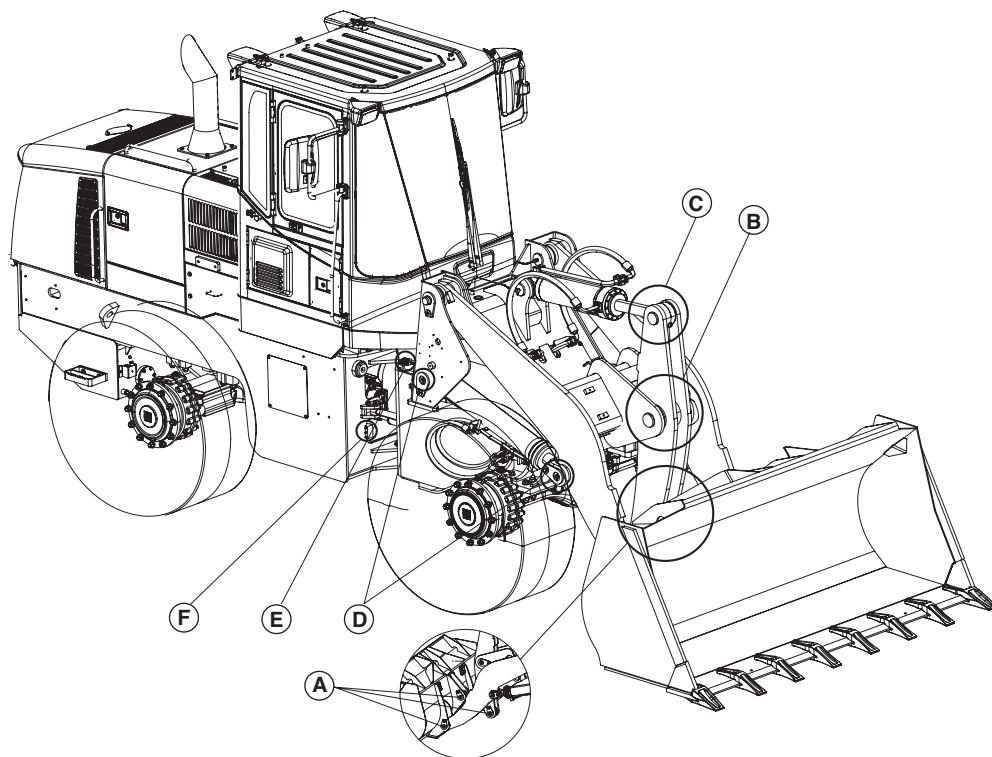

FG006247

Figure 34

A. Bucket hinge pins, 2 locations (Figure 35).

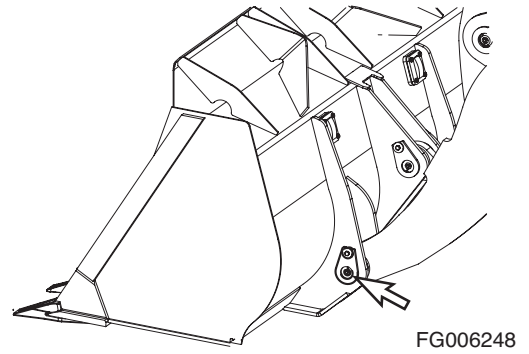

**Figure 35**

Lever link connecting pin, 1 location (Figure 36).

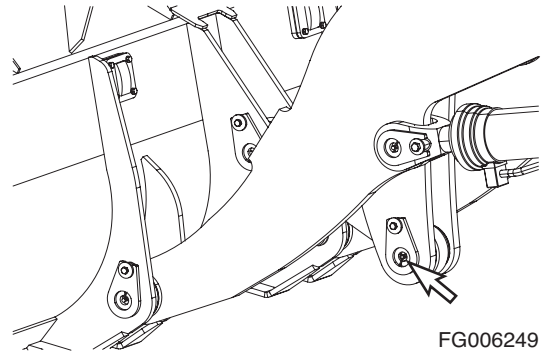

**Figure 36**

Bucket link connecting pin, 1 location (Figure 37).

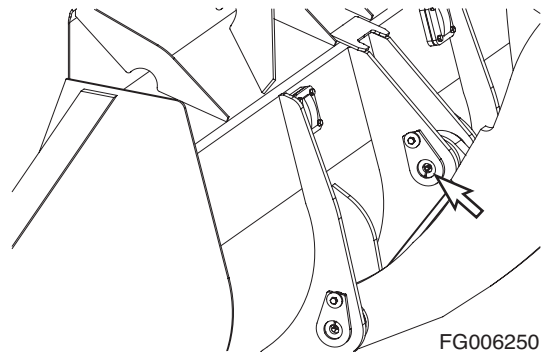

**Figure 37**

B: Arm-lever connecting pin, 1 location. (Figure 40).

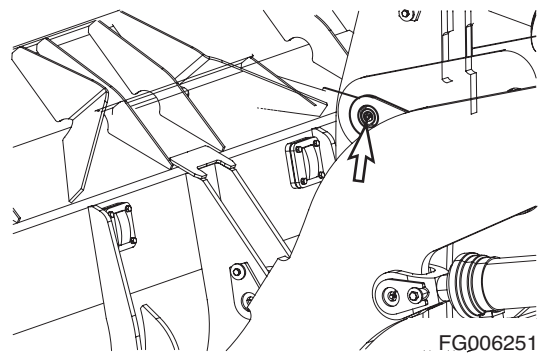

**Figure 38**

C: Bucket cylinder rod end, 1 location. (Figure 41).

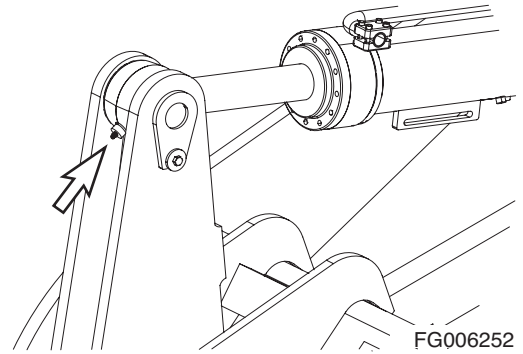

Figure 39

D: Lift cylinder heads (left, right), 2 locations (Figure 40).

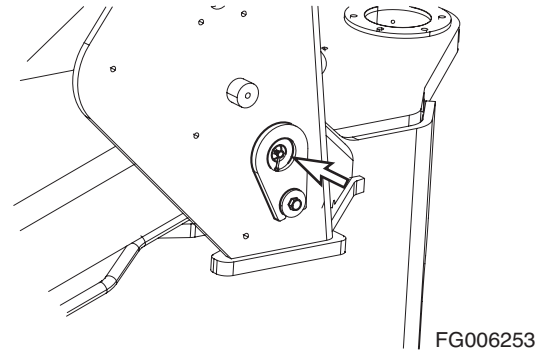

Figure 40

Lift cylinder rod ends, 2 locations. (Figure 43).

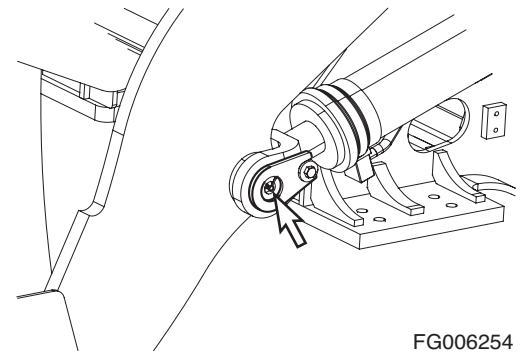

Figure 41

E: Remote location points.

Remote fittings for bucket cylinder head (50 HOUR) (Figure 44, 1).

Remote fittings for loader arm foot end(50HOUR). (Figure 42, 2)

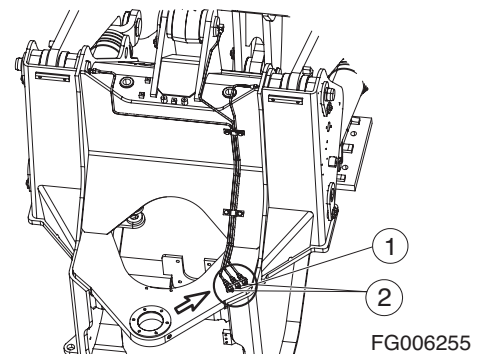
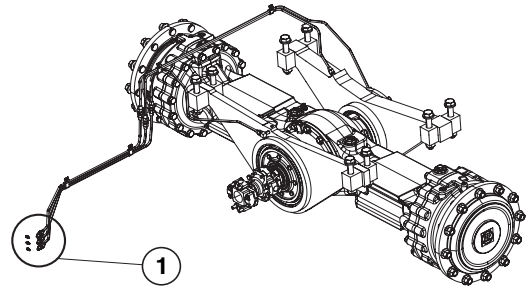

Figure 42

F: Rear Axle pivot (1, Figure 43), 3 locations on right side of machine. Use remote grease fittings mounted on frame shown in Figure 44.



FG006256

Figure 43

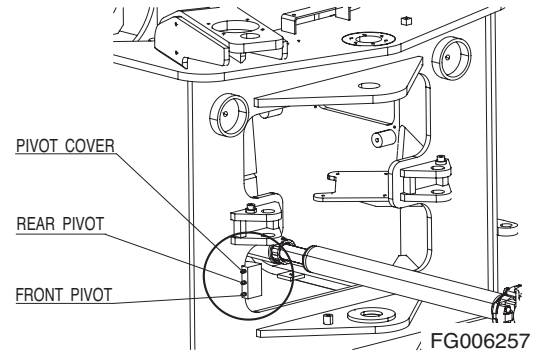

FG006257

Figure 44

## Grease Steering Cylinder Rod and Head Ends

1. Steering cylinder rods, 2 locations, one on each side of machine.

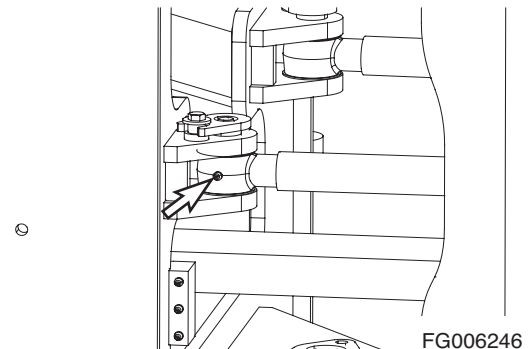

FG006246

Figure 45

2. Steering cylinder head ends, 2 locations. Use remote grease fittings mounted on frame. (1 and 2, Figure 46).

Reference Number	Remote Grease Fittings
1 and 2, 50 Hours	Steering Cylinder Head Ends
3, 250 Hours	Drive Shaft Center Bearing

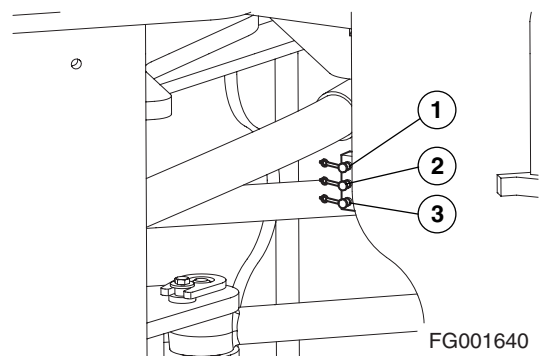

FG001640

Figure 46

## Grease Upper and Lower Center Pins

1. Center pins, upper (Figure 47) and lower (Figure 48).  
Two locations on right side of machine.

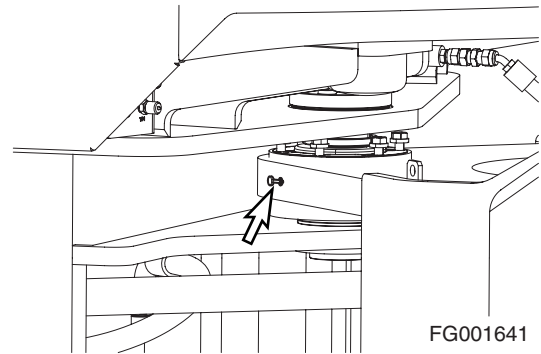

Figure 47

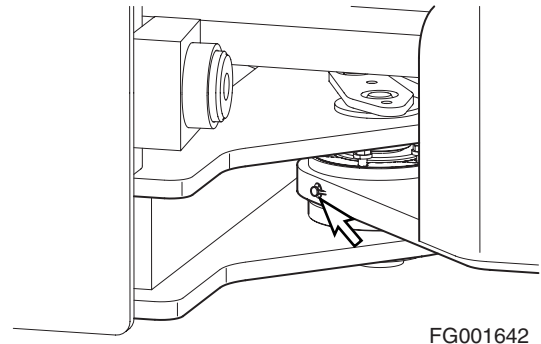

Figure 48

## Replace Engine Oil and Filter (After First 50 Hours)

**NOTE:** *Replace engine oil and filter after first 50 hours on a new machine and every 500 hours thereafter. (See page 4-50)*

## Replace Hydraulic Full Flow Filter (After First 50 Hours)

**NOTE:** *Replace hydraulic full flow filter after first 50 hours of operation or rebuild and every 1,000 Hours thereafter. Follow procedure under 500 hour maintenance interval (See page 4-39)*

## Check Air Conditioner and Alternator Belt Tension (After First 50 Hours)

1. Air conditioner and alternator belt tension must be checked after first 50 hours of operation to comply with new machine break-in requirements. After first check, air conditioner and alternator belt must be checked every 250 hours. Follow procedure printed under 250 hour maintenance interval "Check Air Conditioner and Alternator Belt Tension" on page 4-42.

## Clean Exterior of Radiator, Oil Cooler and Air Conditioner Condenser

1. Dust and dirt accumulation on fins of radiator (1), CAC cooler (4), oil cooler (2), and additional transmission cooler (3), greatly reduce their cooling efficiency. Use compressed air, water and steam to clean fins on radiator, oil cooler, and transmission cooler.

**NOTE:** *On an especially dusty work site, clean fins every 50 hours. On other work sites, clean fins every 500 hours. (See page 4-48)*

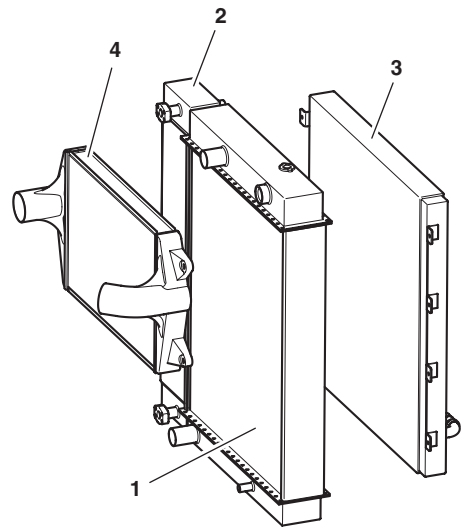

FG004071

Figure 49

## Clean Air Conditioner Outer Filter

This unit is equipped with an air-conditioning system. There are two filters (1 and 2, Figure 50) for air conditioner. They filter out dirt and dust particles from air being circulated into operator's cabin. They are located under the right side control panel.

1. Open access cover on the lower right side of cabin on the outside, to gain access filter.
2. Remove filter (1, Figure 50) and inspect it for damage.
3. Use compressed air to clean filter. If element is very dirty use a mild soap and water solution to clean it.

**NOTE:** *Clean air-conditioning filter every 50 hours and replace a new one every 500 hours of service.*

**NOTE:** *If water was used to clean filter be sure it is completely dry before installation.*

**NOTE:** *In the event that the unit is being operated in a dusty environment, the cleaning and replacement must be performed more frequently if filter is damaged, replace damaged with a new one.*

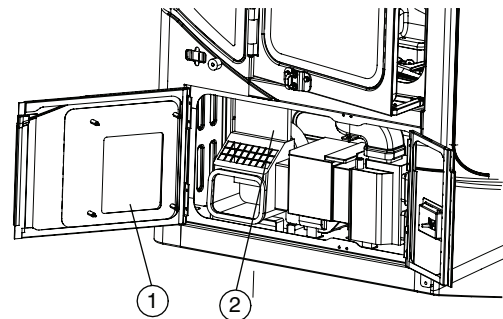
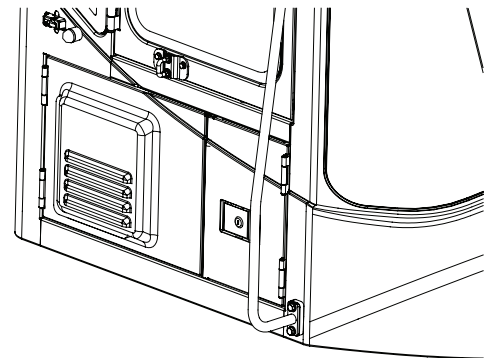

FG003904

Figure 50



## WARNING!

All service and inspection of the air-conditioning system must be performed with the starter switch in the "O" (OFF) position.

# 250 HOUR / MONTHLY SERVICE

## Perform All Daily 10 Hour and 50 Hour Service Checks

### Check Engine Air Intake Precleaner

1. The engine is equipped with a precleaner. Dust, insects, rainwater etc., can be present in the air. The precleaner collects this material and discharges it. This prevents material from being drawn into air cleaner. The precleaner does not need periodic replacement.

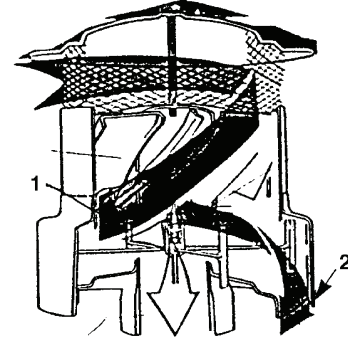

Figure 51

2840A

### Drain Water From Hydraulic Oil Tank



## WARNING!

Be certain that hydraulic oil has cooled before draining water and sediment. Hot oil could splash and cause burns.

The hydraulic tank is pressurized. Unscrew the cap of breather on the top of hydraulic tank to allow pressurized air to vent. After pressure has been released, it is safe to remove either the fill cap or service covers.

1. Position machine on firm, level ground. Lower boom and position bucket on ground. Shut down engine.
2. Position a container under hydraulic tank drain plug. Open tank breather cap (See Figure 20 on page 4-28). Loosen drain valve at bottom of tank (Figure 52). Allow all water and sediment to drain out. Tighten drain valve.

**NOTE:** *Dispose of drained fluids according to local regulations.*

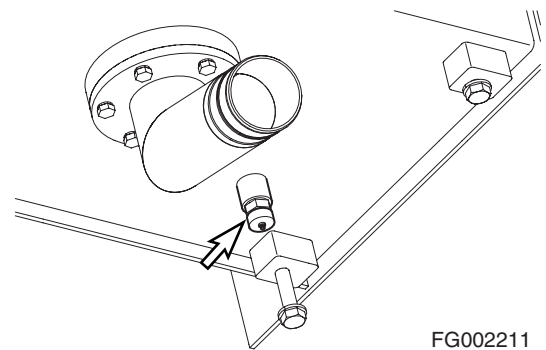

Figure 52

FG002211

## Turbocharger

The turbocharger is lubricated and cooled by the engine lubrication system.

**Important for the function of the turbocharger is that:**

- lubrication and cooling is safeguarded by
  - not racing the engine immediately after it has been started.
  - the engine is allowed to run at low idle for a couple of minutes before it is turned off.
- engine oil is changed and oil filters are replaced at prescribed intervals.
- the air cleaner is serviced regularly and that the exhaust system and lubricating oil lines do not leak.

In case jarring noises can be heard, or if the turbocharger vibrates, it must be reconditioned or replaced immediately.

**Only authorized dealer workshops should carry out work on the turbocharger.**

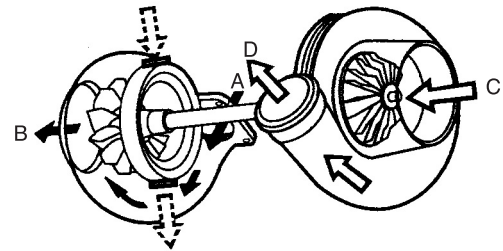
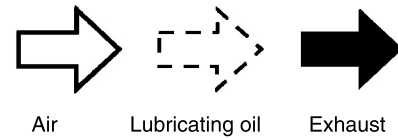

- A Exhaust inlet
- B To exhaust system
- C Air inlet
- D Compressed air

FG004051

**Figure 53**

## Check Air Conditioner and Alternator Belt Tension

Loosen the tension adjusting bolts of the alternator, air con. compressor and air compressor, then take off the cooling fan.

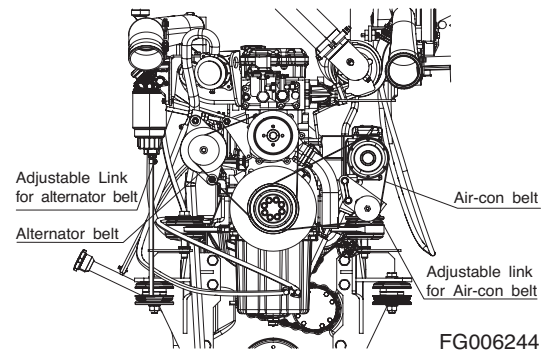

FG006244

**Figure 54**

## Grease Drive Shafts

Grease fitting for center bearing, 1 location. Use remote grease fitting mounted on front frame (3, Figure 55).

Reference Number	Remote Grease Fittings
1 and 2, 50 Hours	Steering Cylinder Head Ends
3, 250 Hours	Drive Shaft Center Bearing

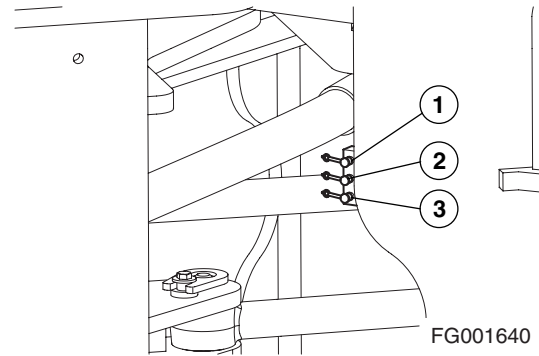

Figure 55

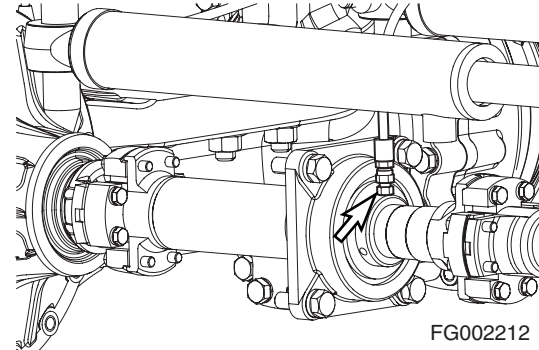

Figure 56

## Transmission Oil and Filter (After First 250 Hours)

**NOTE:** *Transmission oil and filter must be changed after first 250 hours of operation to comply with new machine break-in requirements.*

**NOTE:** *After first change, oil and filter must be changed every 1,000 hours. Follow procedure under 1,000 hour maintenance interval. (See page 4-55)*

## Clean Outer Filter of Air Cleaner

**NOTE:** Clean outer filter every 250 hours / 3 months of service.

**NOTE:** If air cleaner clogged warning light (Figure 57) on instrument panel comes "ON" the air cleaner must be serviced.

**NOTE:** When working in severely dusty conditions, the service interval should be shortened.



### WARNING!

Never clean or attempt to remove the air cleaner filter if the engine is running.

This will allow dirt to be sucked into engine and cause serious engine damage

Always turn engine "OFF" before servicing air cleaner.

1. Locate the air cleaner assembly.

**NOTE:** When it reaches every 250 hours or If indicator light (Figure 57) on instrument panel comes "ON" the air cleaner must be serviced.

**NOTE:** Replace outer filter after cleaning 4 times or every 1,000 hours / 6 months service.

2. Remove and clean rubber evacuator valve (1, Figure 59) from bottom of air cleaner housing cover (2). Inspect seal lips for wear or damage. Replace valve if necessary.

**NOTE:** Install evacuator valve with lips parallel to the cover.

3. Remove the access cover (2, Figure 59) by loosening the latches (3).

4. Remove the outer filter (4, Figure 59) from the housing. Do not remove inner filter (5).

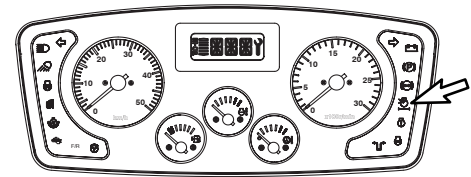

FG008103

Figure 57

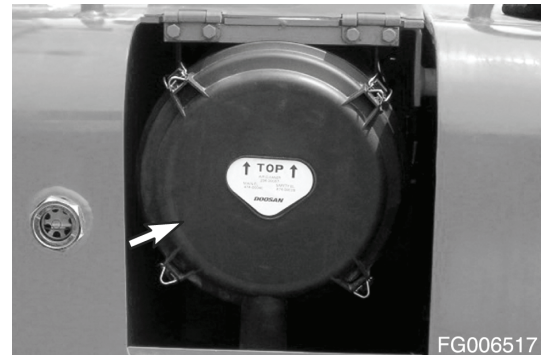

FG006517

Figure 58

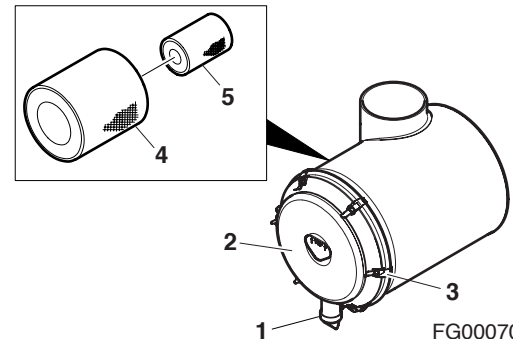

FG000702

Figure 59

- Clean the outer filter (4, Figure 59) by blowing compressed air from the inside of the filter towards the outside. Do not use more than 205 kPa (30 psi) air pressure.



## WARNING!

**If using compressed air to clean the filter, make sure that proper eye protection is worn.**

- Check outer filter by shining a light through it. If small holes or thinner parts are found on the element after cleaning it, replace the filter.
- Clean the inside of the air cleaner body and the inside of the air cleaner cover. Do not use compressed air.
- Properly install the air filter and cover.
- After filter service be sure to install cover with arrows pointing "UP."

**NOTE:** *If after cleaning the outer filter, the air cleaner clogged indicator remains "ON," replace the outer and inner filters. Do not clean inner filter.*



Figure 60

HAOC570L

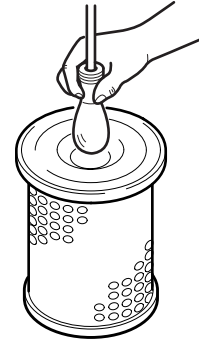

Figure 61

FG000412

## Water Trap

Take care of fuel spillage by using a vessel or a plastic hose.

Drain the water trap every 250 hours.

Draining water from the fuel has to be done by hand.

A nonreturn valve in the filter head prevents the fuel from running back to the tank. As no fuel can run back, the pressure will remain and as a consequence no water will be drained unless new fuel is pumped in.

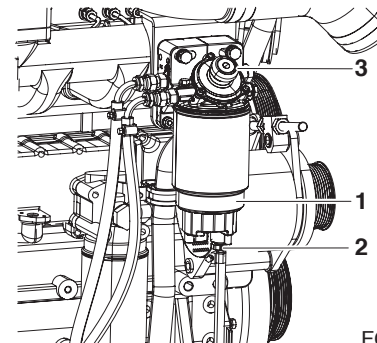

Figure 62

FG008506

### Proceed as follows:

- Place the end of the hose in a vessel.
- Loosen draining nipple (2).
- Pump with hand pump (3) on the primary filter head until all water has been forced out of water trap (1).
- Tighten the draining nipple.

**NOTE:** *Take care of waste oil and liquid in an environmentally safe way!*

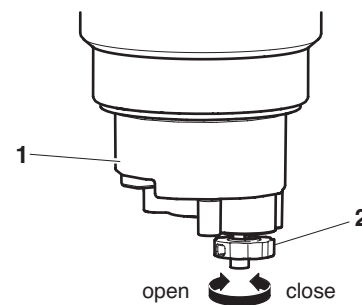

Figure 63

FG000438

# 500 HOUR / 3 MONTH SERVICE

## Perform All Daily, 10, 50 and 250 Hour Service Checks

### Replace Hydraulic System Brake and Pilot Filter

Replace filter in pilot filter. Perform the following steps:

1. Vent hydraulic oil tank.
2. Unscrew element cover (5, Figure 65). Cover is filled with oil. Dispose of oil.
3. Remove O-ring (3, Figure 65) and filter (4).
4. Use a nonflammable, nontoxic solvent to clean out cover (5, Figure 65).
5. Insert a new filter (4, Figure 65) into cover (5). Install a new O-ring (3).
6. Screw cover (5, Figure 65) onto filter head (1).

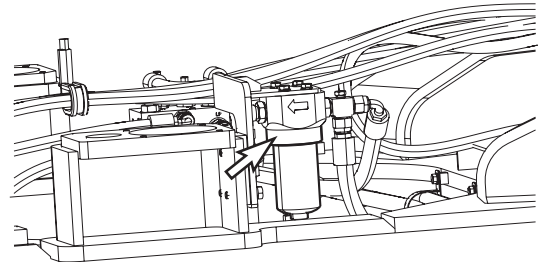

FG006243

Figure 64

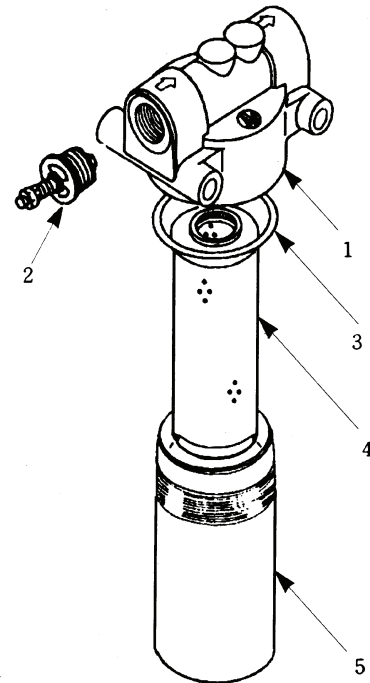

0099A

Figure 65

## Replace Fuel Prefilter

---



### WARNING!

---

Exchange filter after waiting for engine to cool. Be careful of fire hazards. Do not smoke.

---

1. Locate fuel filter inside engine compartment.
2. Position a small container under prefilter. Drain fuel by opening drain valve on bottom of filter.

**NOTE:** *Dispose of drained fluids according to local regulations.*

3. Unscrew fuel filter from head assembly. Discard fuel filter.
4. After cleaning filter head, install new fuel filter. Screw filter on head until gasket contacts head, turn filter 1/3 - 1/2 turn more.

**NOTE:** *Coat fuel filter gasket with fuel.*

**NOTE:** *Fill fuel filter with clean fuel. This will help reduce fuel system priming.*

5. Start engine. After engine has run for a couple of minutes, shut down engine and look for signs of leaks.

If engine does not start, fuel system may need priming. Prime fuel system using the following procedure:

- A. Loosen plug on top of fuel filter head.
- B. Unscrew and pump the hand operated primer pump near fuel injection pump. Pump primer until fuel is present at plug hole in fuel filter head.
- C. Tighten plug in fuel filter head.
- D. Continue to pump primer pump until a strong resistance is felt. Screw primer pump knob back into housing.
- E. Start engine and look for signs of leaks.

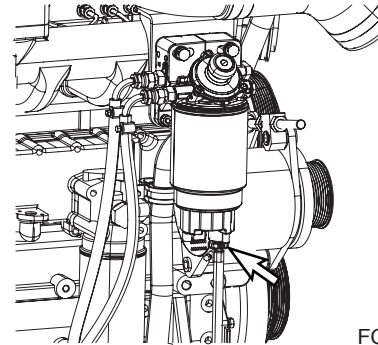

FG006241

Figure 66

# Fuel Filter (Spin-On Type)

## General Information

### DOOSAN Common Rail Fuel System

The DOOSAN Common Rail fuel system requires the use of two fuel filters. The prefuel filter have the following characteristics:

- water separating
- 30-micron rating
- hand priming pump
- chassis mounted.

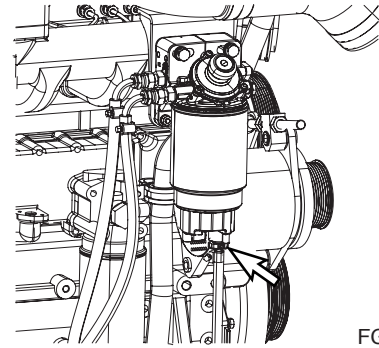

FG006241

Figure 67

The pressure side main fuel filter must have the following characteristics:

- 5-micron rating
- engine mounted

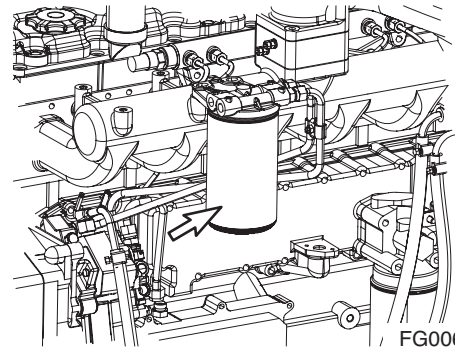

FG006240

Figure 68

## Remove

Disconnect the wiring harness from the fuel heater, if equipped.

Loosen and remove the fuel filter.

Make sure the seal ring does **not** stick to the filter head.

Remove the ring with an O-ring pick, if necessary.

**NOTE:** Both fuel filters must be removed at the same time.

Install new filter. Apply a small amount of oil around filter gasket.

Screw filter on head until gasket contacts head by hand, turn filter 3/4 - 1 turn more with filter wrench.

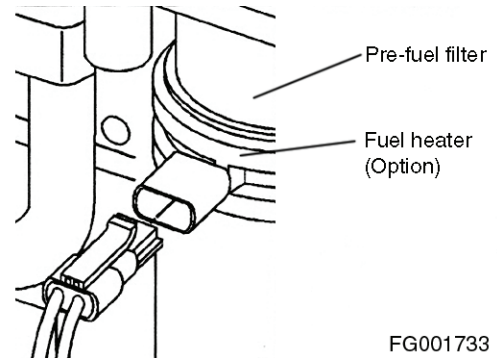

FG001733

Figure 69

## Replace Fuel Filter



Exchange filter after waiting for engine to cool. Be careful of fire hazards. Do not smoke.

1. Locate fuel filter inside engine compartment.
2. Position a small container under fuel filter.
3. Unscrew fuel filter from head assembly. Discard fuel filter.

**NOTE:** *Dispose of drained fluids according to local regulations.*

4. After cleaning filter head, install new fuel filter. Screw filter on head until gasket contacts head, and turn filter 1/2 turn more with a filter wrench.

**NOTE:** *Coat fuel filter gasket with fuel.*

**NOTE:** *Fill fuel filter with clean fuel. This will help reduce fuel system priming.*

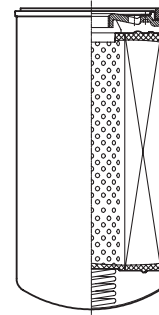

FG000478

Figure 70

## Clean Exterior of Radiator, Oil Cooler and Air Conditioner Condenser

1. Dust and dirt accumulation on fins of radiator, oil cooler, and additional transmission cooler greatly reduce their cooling efficiency. Use compressed air, water and steam to clean fins on radiator, oil cooler, and transmission cooler.

**NOTE:** *On an especially dusty work site, clean fins every 50 hours. On other work sites, clean fins every 500 hours.*

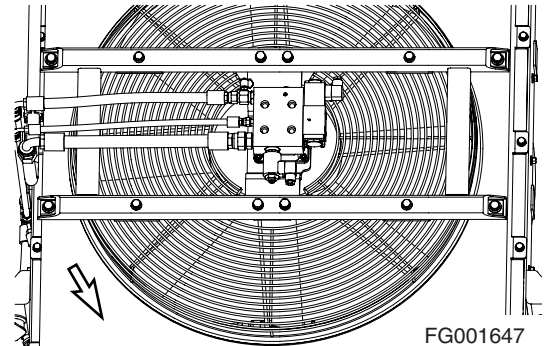

FG001647

Figure 71

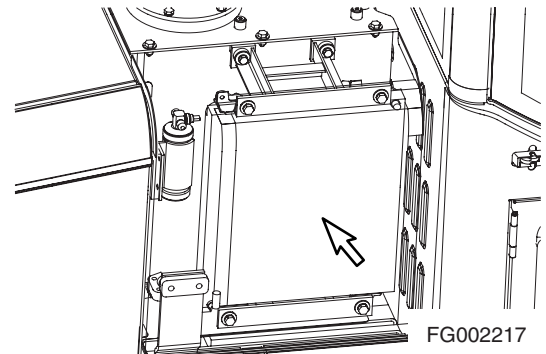

FG002217

Figure 72

## Clean Inner Air Conditioner Filter

This unit is equipped with an air-conditioning system. There are two filters (1 and 2, Figure 73) for air conditioner. The filters out dirt and dust particles from air being circulated into operator's cabin. They are located under the right side control panel.

1. Open access cover on the lower right side of cabin on the outside to gain access filter.
2. Remove filter (2, Figure 73) and inspect it for damage.
3. Use compressed air to clean filter. If element is very dirty use a mild soap and water solution to clean it.

**NOTE:** *Clean air-conditioning filter every 500 hours and replace with a new one every 1,000 hours of service.*

**NOTE:** *If water was used to clean filter be sure it is completely dry before installation.*

**NOTE:** *In the event that the unit is being operated in a dusty environment, the cleaning and replacement must be performed more frequently if filter is damaged, replace damaged with a new one.*

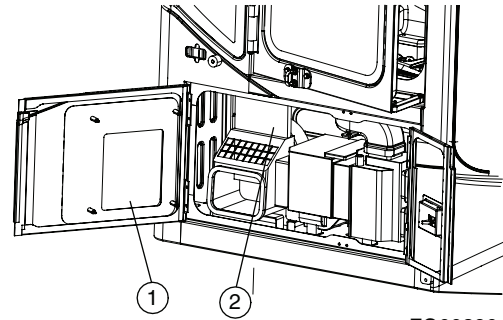
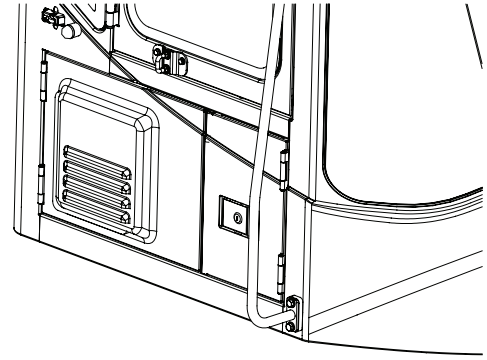

FG003904

Figure 73



## WARNING!

All service and inspection of the air-conditioning system must be performed with the starter switch in the "O" (OFF) position.

## Replace Axle Differential and Planetaries Oil Replacement (After First 500 Hours)

**NOTE:** *The differential and planetaries oil must be drained and refilled after first 500 hours of operation. There after every 1,500 hours of operation. (See page 4-61)*

# Replace Engine Oil and Filter



## CAUTION!

Never attempt to change oil or filter on a hot engine. Hot oil could splash and cause burns. Allow engine to cool down before changing oil or filter.

**NOTE:** Change engine oil and filter after first 50 hours on a new machine and every 500 hours thereafter. Refer to "DL06 Industrial Engines Oil Drain Intervals by Duty Cycle (Hours)" on page 4-19

1. Position a larger container under drain valve beside left wall of fuel tank. Loosen drain valve and allow all engine oil to drain out. Tighten drain valve.

**NOTE:** Oil warming is good when replacing oil. If machine is cold, operate the engine to bring the coolant temperature up to about 40°C (104°F). When the needle of the coolant temperature gauge reaches the middle of the "WHITE ZONE," the temperature is about 40°C (104°F).

**NOTE:** Dispose of drained fluids according to local regulations.

2. Replace engine oil filter (Figure 75). Engine oil filter is a spin-on type. Remove and discard filter.
3. Install new filter. Apply a small amount of oil around filter gasket. Screw filter on head until gasket contacts head by hand, turn filter 3/4 - 1 turn more with filter wrench.

**NOTE:** See "Axle Oils DL400, DL300, DL250" on page 4-16 for capacity and "Table of Recommended Lubricants" on page 4-14 of this manual for recommended oil for the operating conditions.

4. Fill engine with correct oil through oil fill port.
5. Start engine and check engine oil pressure warning light.
6. Shut down engine. Look for signs of leaks at filter. Recheck oil level.

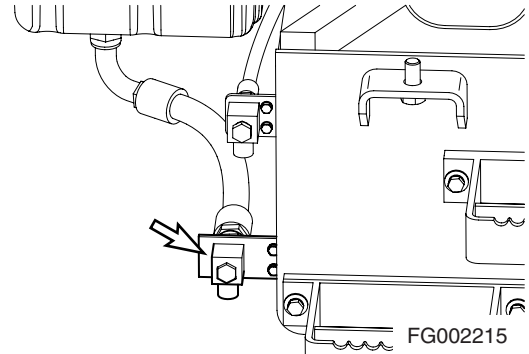

Figure 74

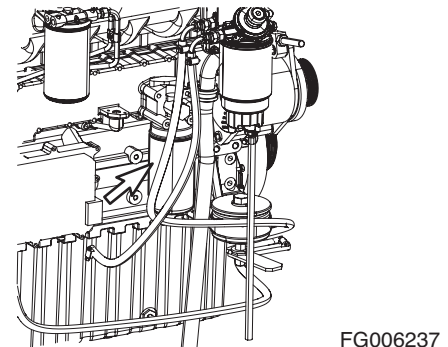

Figure 75



## CAUTION!

---

The lubricating oil filter must be full of oil at start-up to prevent engine damage.

---

Use clean 15W-40 oil to coat the gasket surface of the filter.  
Fill the filter with clean 15W-40 oil.

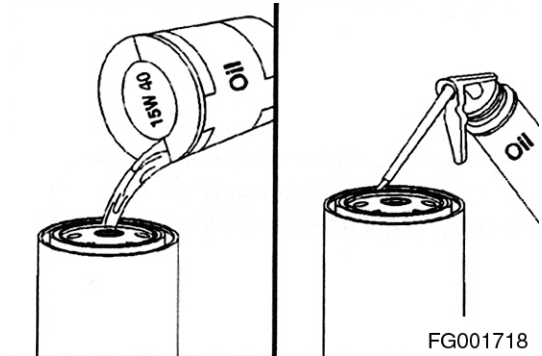

Figure 76

FG001718

## Replace Air Conditioner Outer Filter

**NOTE:** *Clean air-conditioning outer filter every 50 hours and replace with a new one every 500 hours of service. See "Clean Air Conditioner Outer Filter" on page 4-40*

# 1,000 HOUR / 6 MONTH SERVICE

## Perform All Daily 10, 50, 250 and 500 Hour Service Checks

### Air Cleaner

---



## CAUTION!

---

Never remove air cleaner filter while engine is running. This will allow dirt to be sucked into engine and cause serious engine damage. Always turn engine "OFF" before servicing air cleaner.

---

#### Engine, Air Cleaner

The degree of engine wear depends largely on the cleanliness of the induction air. The air cleaner prevents dust and other impurities from entering the engine. Therefore, it is very important that the air cleaner must be checked regularly and maintained correctly.

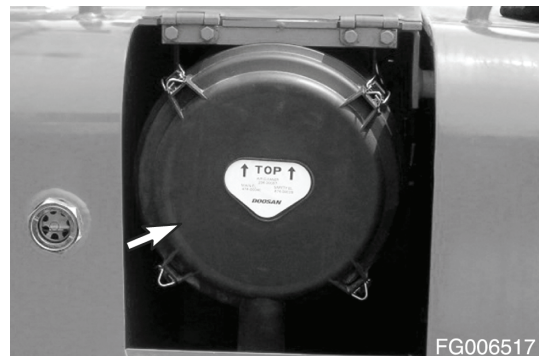

Figure 77

#### Primary Filter, Maintenance and Replacement

When the alarm text "Clogged Air Filter" is shown or every 1,000 hours, the filter must be replaced or be cleaned. The period of operation between filter replacements vary depending on the working environment of the machine. In certain environments the filter needs to be replaced more often.

- The filter can be cleaned according to instructions which your authorized dealer will give you. However, after the filter has been cleaned five times or if it is damaged, it must be replaced.

**NOTE:** *Make a mark on the decal at the end of the secondary filter every time the primary filter is replaced or cleaned.*

- In connection with replacing the filter, the cover for the air cleaner should also be cleaned. It works as a container for particles which have not been trapped in the filter.

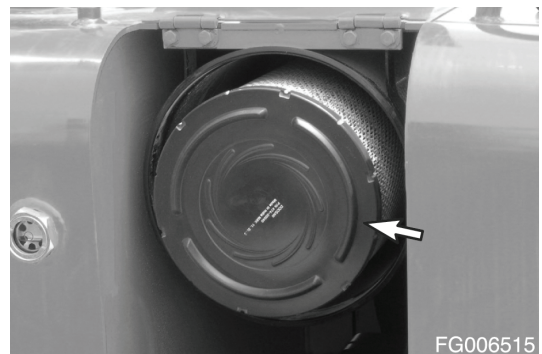

Figure 78

- Check that all hose and pipe connections from the air cleaner to the engine induction manifold are tight. Check tightness of hose clamps.
- If the alarm text remains after replacing the primary filter, also the secondary filter must be replaced. See “9. Air Cleaner Clogged Warning Light” on page 2-19

Do not, under any circumstances, run the engine without a filter or with a damaged one.

Always have a spare filter on hand and keep the filter well protected from dirt.

---

**! CAUTION!**

---

**Never clean the inside of air filter housing while the inner filter is not installed.**

---

### Secondary Filter

Replace the filter every 2,000 hours or when the main filter has been replaced three times.

The filter cannot be cleaned, but must be replaced.

The secondary filter works as a protective filter if the main filter is damaged.

Never remove the secondary filter unless it is to be replaced.

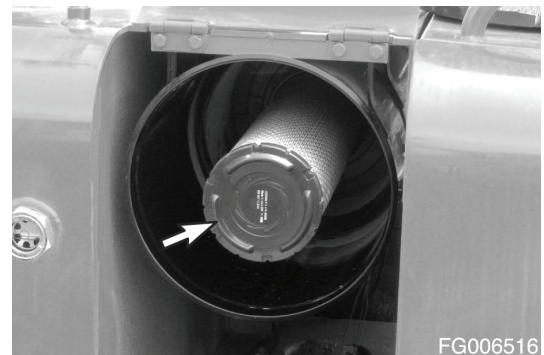

Figure 79

### Replace Outer Air Cleaner Element

---

**! CAUTION!**

---

**Never remove air cleaner element while engine is running. This will allow dirt to be sucked into engine and cause serious engine damage. Always turn engine "OFF" before servicing air cleaner.**

---

1. Open the side access cover at the rear of the cabin.
2. Remove the evacuator valve (1, Figure 80) and air cleaner cover (2, Figure 80).

**NOTE:** *Inspect evacuator valve seal lips for wear or damage. Replace valve if necessary. Install evacuator valve with lips parallel to the cover.*

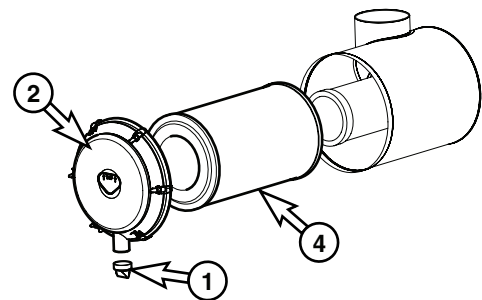

Figure 80

FG000425

3. Remove outer filter (4, Figure 80) from the air cleaner housing.
4. Clean the air cleaner cover and the inside of the air cleaner housing. Do not use compressed air to blow out housing.
5. Install new outer filter.
6. Install air cleaner cover and evacuator valve.

**NOTE:** *Make sure that all gaskets on wing nuts and cover are properly installed and seated.*

## Drain and Replace Transmission Oil and Filter

**NOTE:** *Transmission oil and filter must be changed after first 250 hours of operation to comply with new machine break-in requirements. After first change, oil and filter must be changed every 1,000 hours.*

1. Use two people to perform this operation.
2. Start machine and drive it until transmission fluid has warmed to 80°C (176°F). Park machine on firm, level ground. Lower bucket to ground.
3. Place transmission lever in "NEUTRAL." Apply parking brake. Shut down engine. Block tires.

**NOTE:** *See "Axle Oils DL400, DL300, DL250" on page 4-16, for capacity and "Table of Recommended Lubricants" on page 4-14, of this manual for recommended oil for the operating conditions.*

4. Remove drain plug. Allow all transmission fluid to drain into a receptacle. Clean drain plug.

**NOTE:** *Dispose of drained fluids according to local regulations.*

5. Install drain plug in transmission.
6. Remove inlet strainer. Use a nonflammable, nontoxic solvent to clean strainer.
7. Inspect gasket on inlet strainer. Replace gasket if it is damaged. Install inlet strainer.
8. Remove breather filter. Clean breather filter and install it.

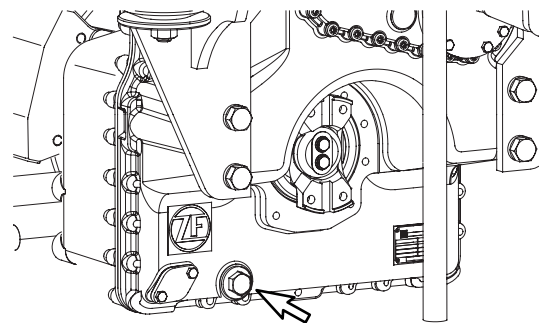

FG004072

**Figure 81**

9. Rotate filter counterclockwise to remove it.
10. Clean filter head.
11. Grease filter gasket and gasket mating surface on filter head.
12. Thread filter onto filter head. Tighten filter 1/2 turn after filter gasket contacts filter head. Filter must be torque to 1.6 - 2.1 kg•m (11.5 - 15 ft lb).

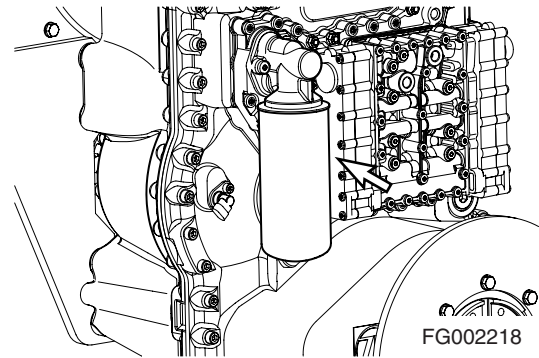

**Figure 82**

13. Fill transmission with fluid through transmission fill tube.

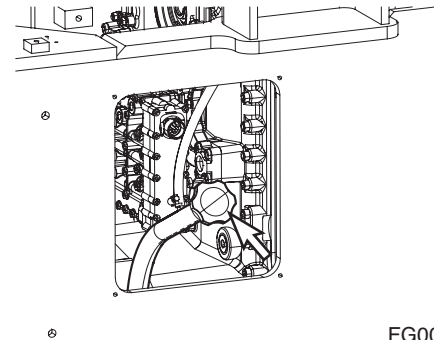

**Figure 83 TRANSMISSION OIL FILL CAP**

14. Add fluid until fluid level is visible in lower "COLD" portion of sight gauge (Figure 84 and Figure 85).
15. Start engine. Idle engine for two minutes. Have a person remain in the cabin.
16. With engine idling, have second person check transmission fluid level again. Add fluid until level reaches "HOT" mark on sight gauge.

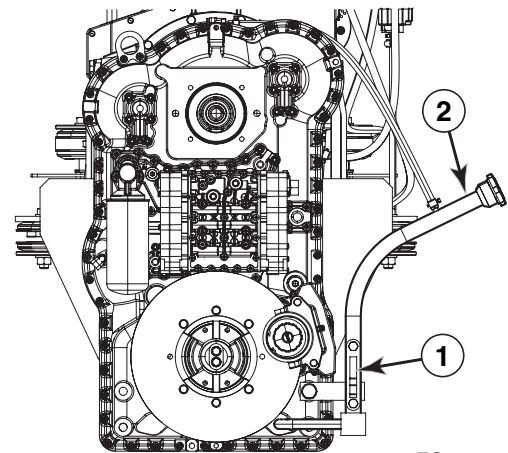

**Figure 84**

1. TRANSMISSION SIGHT GAUGE
2. TRANSMISSION FILL TUBE

- Oil level must be at "HOT" mark or above as shown in (Figure 16).

**NOTE:** If oil level is above top end of sight gauge (completely filling it), drain oil until level is at "HOT" mark.

**NOTE:** If transmission cannot reach an operating temperature of 80°C (176°F), then the oil level must be visible in the sight gauge below the "HOT" mark. Periodically check oil level during the workday to ensure that oil level does not rise above top end of sight gauge.

- Check filter for leaks while engine is running.

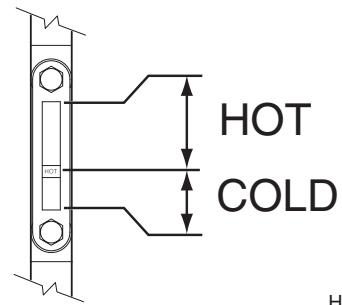

HAAD4540

**Figure 85** TRANSMISSION SIGHT GAUGE

## Clean Fuel Tank and Strainer



### WARNING!

Fuel is flammable and harmful to skin.

- Do not smoke while draining moisture and sediment from fuel tank.
- Do not drain fuel with engine running.
- Do not allow fuel to remain on skin for an extended period of time. Wash thoroughly with soap and water.

**NOTE:** It is easier to clean the fuel tank when it is almost empty.

- Park the machine on a level surface, apply the parking brake, lower the attachment to the ground, and shut down engine.
- Open the drain valve (Figure 86) on the bottom of the fuel tank.
- Drain the remaining fuel into a suitable container.

**NOTE:** Dispose of drained fluids according to local regulations.

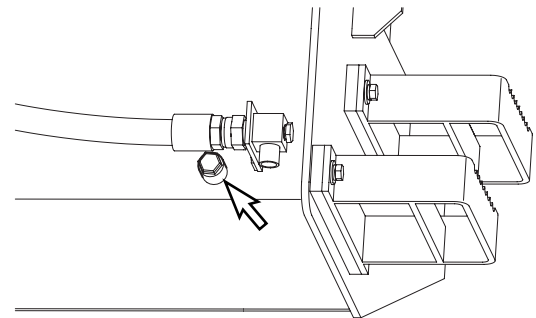

FG002205

**Figure 86**

4. Remove bolts, inspection cover and gasket (Figure 87) from fuel tank.
5. Clean inside of the tank and suction stainer.
6. Install the inspection cover with a new gasket. Tighten the bolts. Do not overtighten.
7. Close drain valve.
8. Fill fuel tank.
9. Check for any leaks at cover and plug.

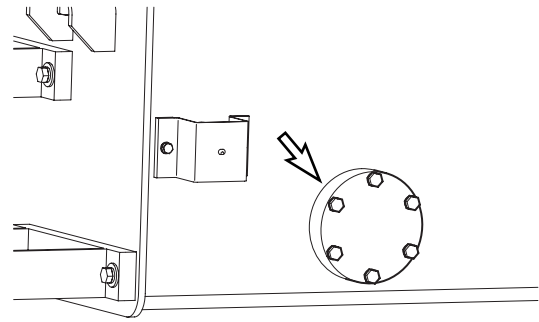

FG002223

Figure 87

## Replace Inner Air Conditioner Filter

**NOTE:** *This unit is equipped with an air filtration system which filters out dirt and dust particles from air being circulated into operator's cabin. This filter must be cleaned out every 500 hours and replaced with a new one every 1,000 hours. For filter replacement See "Clean Inner Air Conditioner Filter" on page 4-50*

**NOTE:** *In the event that the equipment is being operated in a dusty environment, the cleaning and replacement must be performed more frequently.*

## Check Air Conditioner Refrigerant



### WARNING!

**Mixing of tobacco smoke and freon is deadly.**

**Do not smoke while servicing or recharging air-conditioning system.**

1. Apply the parking brake and lower attachment to the ground.
2. Remove the cover.
3. Press the "HI" flow control switch to set maximum air flow.
4. Set the temperature control switch fully to the cool position and fully open the cabin doors.
5. Slightly accelerate the engine to about the middle speed range (compressor speed 1500 - 1800 rpm).

6. Compare the flow of bubbles in the sight glass with the drawings in the following table.



## CAUTION!

Overfilling refrigerant may cause dangerous high-pressure and poor cooling action; and low refrigerant level may cause compressor damage.

Always maintain refrigerant at normal level.

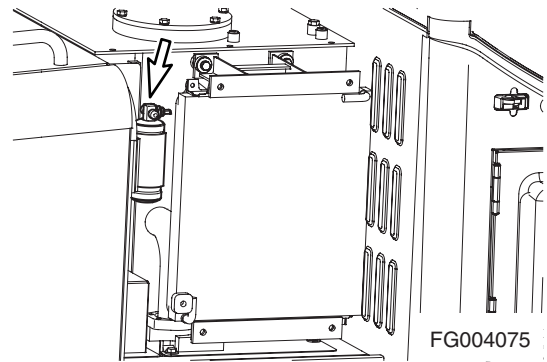
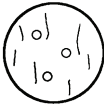
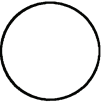
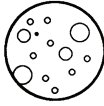

Figure 88

Amount of Refrigerant	Appearance of the Sight Glass	Solutions
Normal	 <p>Almost clear. Any bubbles disappear if the engine speed is increased to 1500 rpm.</p>	Contact your local <i>DOOSAN</i> loader dealer for inspection and recharging refrigerant.
High	 <p>No bubbles are seen.</p>	
Low	 <p>A flow of bubbles is visible.</p>	

## Check and Adjust Engine

Contact your nearest *DOOSAN* loader dealer.  
Contact engine manufacturer for checking and adjusting the following items:

- Engine Compression Pressure.
- Injection Pressure.
- Injection Timing.

## Replace Hydraulic Full Flow Filter

### WARNING!

The hydraulic oil will be hot after normal machine operation. Allow system to cool before attempting to service any of the hydraulic components.

The hydraulic tank is pressurized. Loosen hydraulic oil fill cap slightly to allow pressurized air to vent. After pressure has been released, it is safe to remove either the fill cap or service covers or drain water from the tank.

### IMPORTANT

Make sure to clean any dirt or water from top of the hydraulic tank, especially around fill port and filter ports.

**NOTE:** *Replace hydraulic full flow filter after first 50 hours of operation or rebuild and every 1000 Hours thereafter.*

1. Loosen breather cap on hydraulic tank. (See Figure 20 on page 4-28).
2. Clean filter cover (2, Figure 89) and tank around cover.
3. Remove bolts (1, Figure 89) from cover (2).
4. Lift cover (2, Figure 89) and O-ring (4) off tank. Control spring (3) sits beneath cover. Remove spring (3).
5. Remove valve (5, Figure 89) and filter (6) from tank.
6. Clean underside of cover (2, Figure 89).
7. Set a new element (6, Figure 89) and valve (5) down into tank. Press element down onto its base until top of element is approximately 4 mm (0.157") below edge of tank.
8. Install a new O-ring (4, Figure 89) on cover (2). Set spring (3) into place on element (6).
9. Set cover (2, Figure 89) into place over element (6). Install bolts (1) through cover (2) and tighten them.
10. Tighten breather cap on tank.

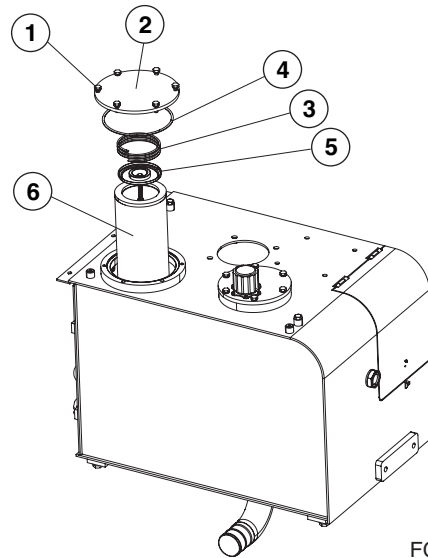

Figure 89

FG006233

# 1,500 HOUR / 9 MONTH SERVICE

## Perform All Daily 10, 50, 250 and 500 Hour Service Checks

### Replace Axle Differential and Planetaries Oil

**NOTE:** *Oil in both front and rear axles must be replaced after first 500 hours of operation to comply with new machine break-in requirements. After that, axle oil check must be done every 500 hours of operation and replacement must be done every 1,500 hours.*

Each axle contains a center differential, and a planetary on each end. The same oil lubricates the center differential and planetaries. These sections of the axle are connected, but the oil flows very slowly between them. When checked, oil must be checked and refilled at the level/fill plug on the differential housing.

To drain and replace oil in an axle, perform the following steps:

1. Drive machine onto a level surface. Apply parking brake. Block wheels.
2. Clean areas around drain plugs on both ends of axle. Remove plugs and allow oil to drain into a suitable container.

**NOTE:** *See "Axle Oils DL400, DL300, DL250" on page 4-16 for capacity and "Table of Recommended Lubricants" on page 4-14 of this manual for recommended oil for the operating conditions.*

**NOTE:** *Dispose of drained fluids according to local regulations.*

**NOTE:** *Plug Size: M24 x 1.5*

*Tightening Torque: 7.1 kg•m (51 ft lb)*

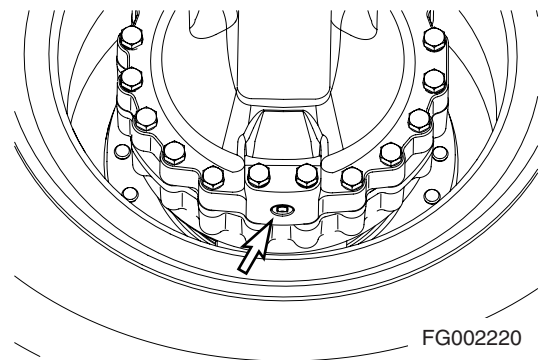

**Figure 90**

3. Clean area around level plug (1, Figure 91) and drain plug (2) on center differential. Remove level plug (1) and drain plug (2). Allow oil to drain into a suitable container.

**NOTE:** Plug Size (1, Figure 91):  
M36 x 1.5

*Tightening Torque: 13.2 kg•m (95 ft lb)*

Plug Size (2, Figure 91):  
M24 x 1.5

*Tightening Torque: 7.1 kg•m (51 ft lb)*

4. Install drain plug (2, Figure 91) into center differential, and tighten. Install drain plugs on both ends of axle, and tighten.
5. Pump oil into level plug hole on center differential. Add oil until oil level is even with bottom of plug hole. Recheck level on center differential. Add oil if necessary. When oil level is satisfactory at the level plug hole, install and tighten level plug.

**NOTE:** Allow oil time to fill planetaries.

6. Repeat procedure for other axle.

**NOTE:** Plug Size (1, Figure 92):  
M36 x 1.5

*Tightening Torque: 13.2 kg•m (95 ft lb)*

Plug Size (2, Figure 92):  
M24 x 1.5

*Tightening Torque: 7.1 kg•m (51 ft lb)*

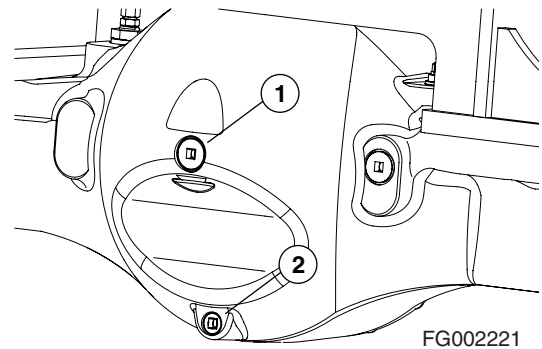

**Figure 91**

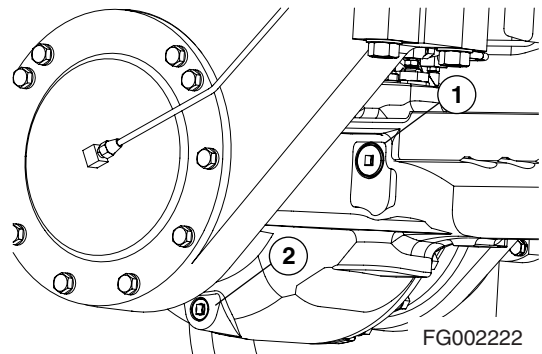

**Figure 92**

## Axle Brake Disk Wear Measurement

**NOTE:** A wear measurement on the multidisk brake must be made at least once a year, especially in case of a change in braking behavior like, e.g.

- Braking noise.
- Braking power reduced.
- Deceleration changed.
- Brake fluid level changed.
- Braking pressure changed.

A wear measurement must be made on both output sides.

Remove screw plug, actuate brake and determine "Dimension X" according to Figure 93 and Figure 94 using a feeler gauge. "Dimension X" corresponds with the thickness of an inner brake disk on the piston side.

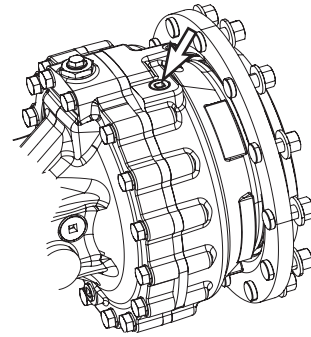

FG006232

Figure 93

**NOTE:** If Dimension X less than or equal to 4.0 mm (0.16 in), the lined disks on both sides must be replaced.

Install level plug with a new O-ring.

**NOTE:** Tightening Torque: = 7.1 kg•m (51 ft lb)

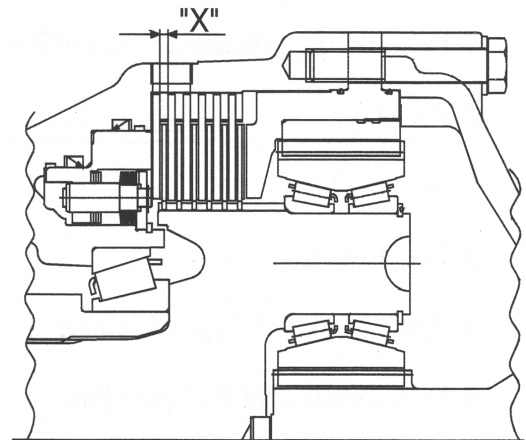

BSO0440S

Figure 94

## 2,000 HOUR / YEARLY SERVICE

### Perform All Daily, 10, 50, 250, 500 and 1,000 Hour Service Checks

#### Replace Inner Air Cleaner Element

---



#### CAUTION!

---

Never remove air cleaner element while engine is running. This will allow dirt to be sucked into engine and cause serious engine damage. Always turn engine "OFF" before servicing air cleaner.

---

1. Replace inner filter when outer filter is replaced.
2. After removing outer filter, remove wing nut and inner filter.
3. Clean out inside of air cleaner housing. Do not use compressed air to blow out housing.
4. Install new inner filter, and secure it into position with wing nut. Do not clean and reuse inner filter.
5. Install new outer filter, and secure it into position with wing nut.
6. Install air cleaner cover.

**NOTE:** *Make sure that all gaskets on wing nuts and cover are properly installed and seated.*

#### Check Steering, Brake, Drive Shaft, Engine, and Fuel System

#### Replace Pipes and Hoses

1. Replace hoses that carry brake fluid to wheel brakes. Also replace hoses that carry hydraulic fluid to steering cylinders.
2. It is difficult to determine condition of many hoses. The best way to ensure safe operation and to maintain maximum performance is to replace hoses on a regular basis. If any brake or steering hoses become damaged or appear defective in any way, replace them immediately despite time interval since their last replacement.

## Bleed Brakes

When brake hoses or brake tubes are replaced, air can be introduced into brake hydraulic system. Air can cause brakes to operate intermittently, which is a dangerous condition. Never operate machine with air in brake hydraulic system. A spongy feel when pressing brake pedal is a sign that air is present in brake hydraulic system.

To bleed air out of brake hydraulic system, perform the following steps:

1. Start engine and place transmission in "NEUTRAL."

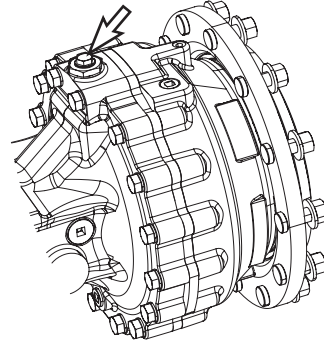

FG006231

Figure 95

2. Remove plug (Figure 96) on axle. Increase the height of bleeder (1, Figure 96) by using special tool (4, Figure 96). Place one end of a plastic hose (2, Figure 96) over bleeder screw (1). Place other end of hose in a container (3) filled with brake fluid.

**NOTE:** *Dispose of drained fluids according to local regulations.*

3. Station one person in operator's cabin, and one person at bleeder screw on axle being bled.
4. Open bleeder screw (1, Figure 96). Then press down on brake pedal until it rests on floor of cabin. Hold pedal down on floor of cabin. Close bleeder screw while pedal is being held down. After bleeder screw has been closed, allow brake pedal to return to upright position. Continue to open bleeder screw and press down pedal as described in this step, until fluid expelled from bleeder hose has no air bubbles present.
5. Securely close bleeder screw (1, Figure 96). Install plug in axle.
6. Perform bleeding procedure on other three locations.

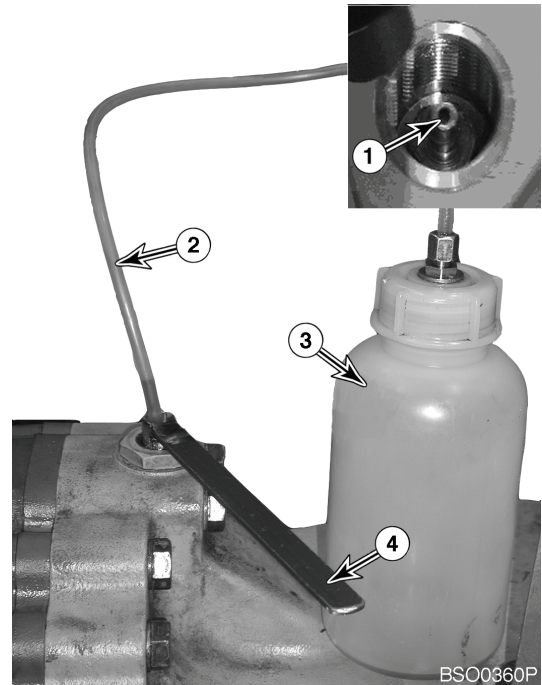

BSQ0860P

Figure 96

## Replace Radiator Coolant

**NOTE:** Do not mix ethylene glycol and propylene glycol antifreeze together. If the two are mixed, the protection level will be reduced to the level of the ethylene glycol. See "Engine Cooling System" on page 4-75, for further details.

**NOTE:** This unit was factory filled with propylene glycol.



### WARNING!

Allow the engine to cool before releasing the radiator cap. Make sure to loosen the cap slowly to release any remaining pressure.

Radiator cleaning is performed while the engine is running. Take extreme caution when working on or near a running engine. Make sure to lock out and tag the controls notifying personnel that service work is being performed.

Do not remove the radiator cap unless it is required. Observe the coolant level in the coolant recovery tank.

1. Slowly open the radiator cap (Figure 97) to allow any pressure to escape.

**NOTE:** See "Fluid Capacities" on page 4-19 for capacity.

2. Place a container under the radiator and open the drain valve (Figure 98).

**NOTE:** Dispose of drained fluids according to local regulations.

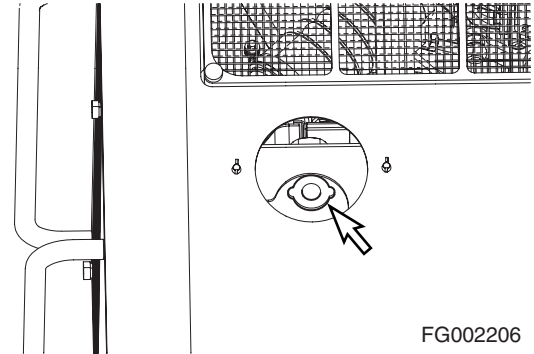

Figure 97

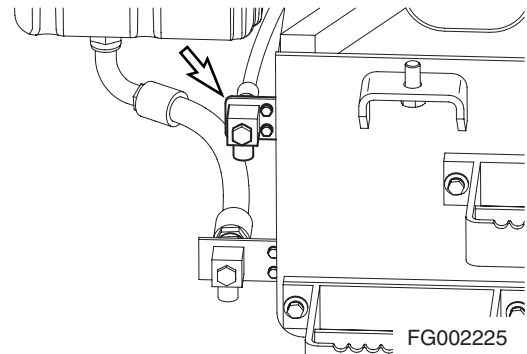

Figure 98

# Replace Hydraulic Oil and Clean Oil Suction Strainer



## CAUTION!

Be certain that hydraulic oil has cooled before draining it. Hot oil could splash and cause burns.

1. Raise boom to its highest position. Tilt bucket back as far as possible, and shut down engine.

**NOTE:** See "Fluid Capacities" on page 4-19 for capacity.

2. Position a catch tank beneath hydraulic tank drain plug. Open tank breather cap. (See Figure 20 on page 4-28). Remove drain plug from bottom of tank. (Figure 100). Allow all hydraulic oil to drain out.

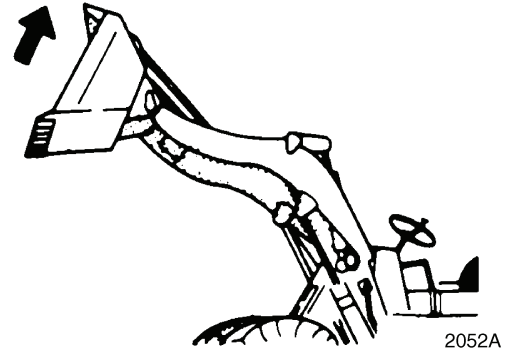

Figure 99

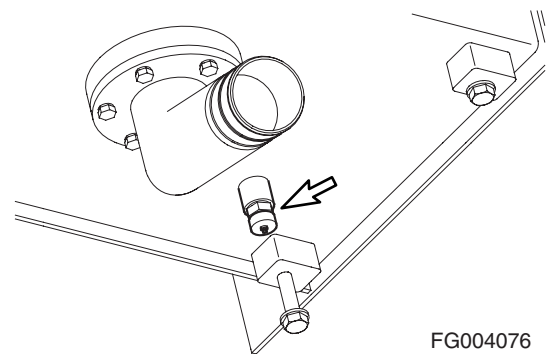

Figure 100

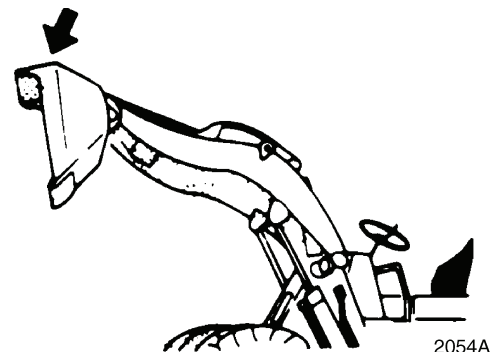
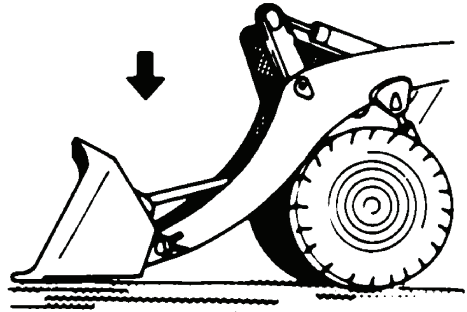

Figure 101



2055A

Figure 102

3. Without starting engine, operate controls to dump bucket. (Figure 101). Then operate controls to lower boom. (Figure 102). This will drain oil out of boom and bucket cylinders.
4. Replace full flow hydraulic filters as described under "Loosen breather cap on hydraulic tank. (See Figure 20 on page 4-28)." on page 4-60.
5. Remove and clean pump inlet strainer (Figure 103) inside hydraulic tank.
  - A. Carefully remove bolts and cover (1), from top of hydraulic oil tank. There is a spring (2) under the cover that will force the cover up.
  - B. Remove spring (2, Figure 103) and suction filter (4) by pulling on rod (3).
  - C. Clean in side and outside of strainer. Replace strainer if it is broken.
  - D. Position strainer on boss portion of suction pipe.
  - E. Fill hydraulic oil tank. Check level using sight gauge on side of tank.
6. Install tank drain plug. Refill tank by pouring oil in through breather cap opening. Install and tighten breather cap.

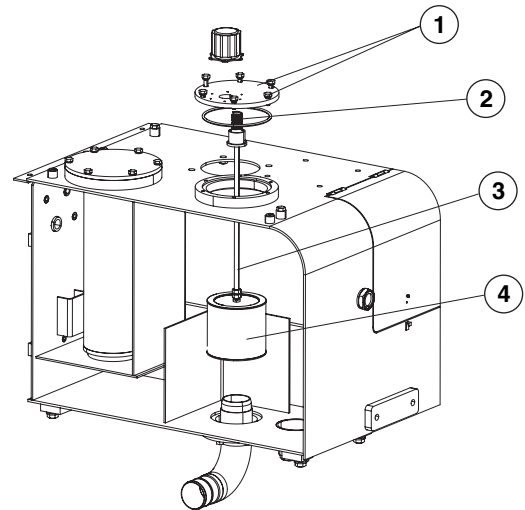

FG006228

Figure 103

7. Start engine and operate controls to raise and lower bucket a few times. (Figure 104). Raise and lower boom a few times. (Figure 105). Lower bucket to ground.
8. Check tank sight gauge. (See Figure 19 on page 4-28). Oil level must be between upper limit and lower limit on sight gauge. Remove breather cap and add oil if necessary.

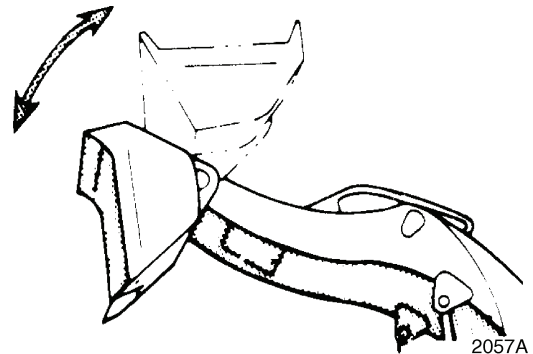

2057A

Figure 104

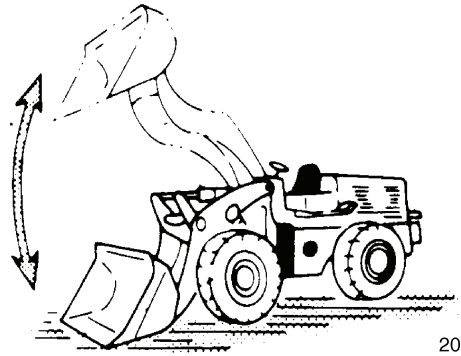

2058A

Figure 105

## Check Brake Accumulator

---



### WARNING!

---

**Pressurized Nitrogen gas in brake accumulator may explode causing serious injury or death.**

**Never service brake accumulator unless properly trained.**

---

Test the brake accumulator for proper precharge of Nitrogen gas:

1. Park the machine on a level surface, apply the parking brake, lower the attachment to the ground.
2. Run the engine at low idle for five minutes to fill the brake accumulator with oil.
3. Shut down engine.
4. Turn the starter switch to "ON" position.
5. Count the number of times you can depress the right-hand brake pedal before the brake warning light comes on.
6. If the number counted is less than five (5), there is some problem with the accumulator. Contact your nearest *DOOSAN* dealer.

# 12,000 HOUR / SIX YEAR SERVICE

## Hose In-service Lifetime Limit (European Standard ISO 8331 and EN982 CEN)

European regulations state that the in-service life of any hydraulic hose may not exceed six years. *DOOSAN* recommends the following:

- Hoses at the customer premises cannot be stored more than 2 years before being discarded or installed on a machine.
- In-service lifetime of hoses fitted on a machine can never exceed 6 years, but replace hoses described in “Replace Pipes and Hoses” on page 4-64, every year. Always replace hoses having exceeded the allowed in-service lifetime irrespective of the external appearance/wear.
- Always store hoses in a dark place at a maximum of 65% relative humidity, between 0°C (32°F) and 35°C (95°F) but as close as possible to 15°C (59°F) and away from copper, manganese or tube generating Ozone.

# SEVERE CONDITIONS MAINTENANCE

Operating Condition	Required Maintenance
Mud, Water, Rain	1. Check for loose fittings, obvious damage to machine, or any fluid leakage.
	2. After completing operations, clean mud, rocks, or debris from machine. Inspect for damage, cracked welds, or loosened parts.
	3. Perform all daily lubrication and service.
	4. If machine was working in salt water or other corrosive materials, be sure to flush equipment with fresh water.
Extremely Dusty or Hot Environment	1. Clean engine air filter on a more frequent basis.
	2. Clean radiator and oil cooler fins to remove dirt and dust.
	3. Clean fuel system intake strainer and fuel filter more frequently.
	4. Inspect starter motor and alternator, and clean as often as necessary.
Rocky Terrain	1. Check wheels, tires, rims, and valve stems for damage or excessive wear.
	2. Inspect for loose or damaged fittings and bolts.
	3. On a more frequent basis, inspect bucket and boom for damage or excessive wear.
	4. Install a top guard and front guard as necessary for protection against falling rock.
Extreme Cold	1. Use proper grade of fuel for cold temperatures.
	2. Use a gauge to check antifreeze to be sure that it will provide protection for coldest temperature expected.
	3. Use a hydrometer to check condition of batteries. In extremely cold weather, remove batteries at night and store them in a warm area.

# BOLT TORQUE CHART

## Tightening Torque Specifications for Metric Bolts (For coated threads, prelubricated assemblies)

Grade	Gr. 8.8		Gr. 10.9		Gr. 12.9	
	Dia.	kg·m	ft lb	kg·m	ft lb	kg·m
5 mm x std.	0.59	4.3	0.79	5.7	1.0	7.2
6 mm x std.	1.00	7.3	1.38	10	1.66	12
8 mm x std.	2.49	18	3.46	25	4.15	30
8 mm x 1.0	2.76	20	3.87	28	4.56	33
10 mm x std.	4.84	35	6.92	50	8.30	60
10 mm x 1.0	4.84	35	7.05	51	8.30	60
12 mm x std.	8.57	62	11.89	86	14.52	105
12 mm x 1.5	9.00	65	12.59	91	14.94	108
14 mm x std.	13.55	98	18.95	137	23.10	167
14 mm x 1.5	14.94	108	21.02	152	24.89	180
16 mm x std.	20.88	151	29.46	213	35.54	257
16 mm x 1.5	22.54	163	31.53	228	38.03	275
18 mm x std.	28.90	209	40.52	293	48.41	350
18 mm x 1.5	32.50	235	45.92	332	55.04	398
20 mm x std.	40.94	296	57.95	419	69.01	499
20 mm x 1.5	46.05	333	64.03	463	77.03	557
22 mm x std.	54.90	397	77.86	563	93.08	673
22 mm x 1.5	61.00	441	86.02	622	105.00	759
24 mm x std.	71.00	513	100.00	723	120.00	868
24 mm x 2.0	78.00	564	109.95	795	130.00	940
27 mm x 2.0	115.06	832	160.00	1157	195.00	1410

# ELECTRICAL SYSTEM

## Check Battery Condition

---

### **WARNING!**

---

Before starting any battery service work, make sure to shut the engine off and turn the starter switch to the "I" (OFF) position.

The batteries create hydrogen gas. An explosion hazard exists, particularly with a deeply discharged battery. Make sure that open flames, burning objects or sparks are kept away from the battery compartment.

Battery electrolyte is diluted sulfuric acid. Take extreme caution when handling the batteries. The electrolyte can cause severe chemical burns. If any electrolyte gets on your clothing or skin, wash it off immediately with large quantities of water. If the electrolyte gets into your eyes, flush them immediately with a large quantity of water and contact a doctor at once.

When installing a battery, wear safety glasses at all times.

When removing a battery, remove the negative (-) or ground terminal first, and then the positive (+) terminal. This will prevent sparks or arcing that could cause an explosion. When installing a battery, connect the positive terminal first and then the negative terminal. Make sure to fully tighten the terminal clamps.

---

1. In colder weather a greater drain is placed on the batteries when they are used for the preheat cycle and when starting a cold engine. Battery performance decreases as the temperature gets lower.
2. In extremely cold weather, remove the batteries at night and move them to a warm location. This will help to keep them at a higher power level.
3. Inspection of battery electrolyte level.

**NOTE:** *The battery installed at the factory is a Maintenance Free (MF) type. Electrolyte under normal conditions should remain at its proper level.*

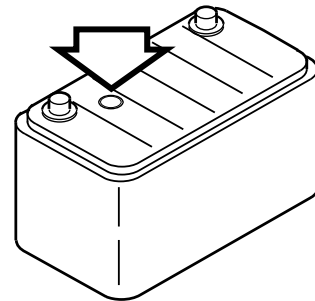

Figure 106

HJB5002L

4. Inspect charge condition of battery by looking at the indicator light built into battery.

- GREEN: Normal.
- BLACK: Insufficient charging - check alternator.
- TRANSPARENT: Insufficient battery electrolyte - replace with new battery.

**NOTE:** *Colors may vary from one battery manufacturer to another. Always refer to instructions on battery.*

*The batteries should always be replaced in pairs. Using an old battery with a new one will shorten the life span of the new battery.*

# ENGINE COOLING SYSTEM

## General

Keeping an engine's cooling system in peak operating condition, can have many benefits to keeping a machine in good operating condition. A properly functioning cooling system will; improve fuel efficiency, reduce engine wear, and extend component life.

Always use distilled water in the radiator. Contaminants in tap water neutralize the corrosion inhibitor components. If tap water must be used, it should not exceed 300 ppm hardness, or contain more than 100 ppm of either chloride or sulfate. Water that has been treated with a water softener also contains salt that will cause corrosion of components. Water from creeks and stagnant pools usually contains dirt, minerals and/or organic material that are deposited in the cooling system and impair cooling efficiency. Distilled water is the best.

Engine overheating is often caused by bent or clogged radiator fins. The spaces between the fins can be cleaned by use of air or water under pressure. When straightening bent fins, use care not to damage the tubes or break the bond between the fins and the tubes.



## WARNING!

---

**Pressure at air nozzle must not exceed 2.1 kg/cm<sup>2</sup> (30 psi). Always wear goggles when using compressed air.**

**Do not pour cold water into radiator when engine is very hot and water level is below the top of the tubes. Such action could result in damage to engine cylinder heads.**

---

Heavy duty diesel engines require a balanced mixture of water and antifreeze. Drain and replace the mixture every year or 2,000 hours of operation, whichever ever comes first. This will eliminate buildup of harmful chemicals.

Antifreeze is essential in any climate. It broadens the operating temperature range by lowering the coolant's freezing point and by raising its boiling point. Do not use more than 50% antifreeze in the mixture unless additional freeze protection is required. Never use more than 68% antifreeze under any condition.

## Types of Antifreeze

There are two main classifications of antifreeze available on the market today.

1. Ethylene Glycol - Standard Life Antifreeze
2. Propylene Glycol - Extended Life Antifreeze

Ethylene glycol (standard life antifreeze) has been on the market for many years. Its chemical properties do not provide the improved corrosion resistance that propylene glycol (extended life antifreeze) does. Ethylene glycol is also very hazardous to the environment, people and animals. *DOOSAN* recommends that ethylene glycol be replaced with propylene glycol.

The newer propylene glycol antifreeze comes in many different colors. Some of the colors are pink, red, orange and yellow. There are even some that come in a blue-green color. The blue-green color makes it very difficult to tell the difference of what type of antifreeze is in a cooling system. The colors are only a dye added to the clear antifreeze. Do not rely on color. Keep careful machine records of what brand and type of antifreeze is used in the unit. If you are unsure of what type of antifreeze is in the system, drain and flush the system.

**NOTE:** *Do not mix ethylene glycol and propylene glycol antifreeze together. If the two are mixed, the protection level will be reduced to the level of the ethylene glycol.*

## Antifreeze Concentration Tables

Ethylene Glycol - Standard Life Antifreeze (1,000 Hour / 6 Months)		
Ambient Temperature	Cooling Water	Antifreeze
-10°C (14°F)	80%	20%
-15°C (5°F)	73%	27%
-20°C (-4°F)	67%	33%
-25°C (-13°F)	60%	40%
-30°C (-22°F)	56%	44%
-40°C (-40°F)	50%	50%

Propylene Glycol - Extended Life Antifreeze (2,000 Hour / Yearly)		
Ambient Temperature	Cooling Water	Antifreeze
-10°C (14°F)	78%	22%
-15°C (5°F)	71%	29%
-20°C (-4°F)	65%	35%
-25°C (-13°F)	59%	41%
-30°C (-22°F)	55%	45%
-40°C (-40°F)	48%	52%

# HANDLING OF ACCUMULATOR

---



## WARNING!

---

Even though the engine is stopped, the hydraulic accumulators for the pilot system are still charged. Do not disconnect any pilot system hoses until accumulator pressure has been released from the circuit. To release pressure, turn the starter switch to "I" (ON) position and operate pilot control valve lever and brake pedal. Even though the engine is shut down, hydraulic actuated components may move while releasing pilot pressure. Keep all personnel away from machine while performing this operation.

- Set pilot cutoff switch to "O" (OFF) position after stopping engine.
  - Do not mishandle accumulator(s). They are very dangerous because they contain high-pressure nitrogen gas.
  - Do not punch a hole or apply heat or fire to an accumulator.
  - Do not weld on accumulator, or try attaching anything to it.
  - When replacing an accumulator, contact a *DOOSAN* distributor or sales agency so the gas can be properly released.
  - Wear safety goggles and protective gloves when working on an accumulator. Hydraulic oil under pressure can penetrate the skin and cause serious injuries.
- 

Release pilot accumulator pressure using the following procedure:

1. Lower front attachment (bucket) to ground.
2. Shut down engine.
3. Set pilot cutoff switch on "I" (ON) position.
4. Turn starter switch to "I" (ON) position.
5. Fully move pilot control valve lever in all directions.
6. Repeatedly press brake until brake oil pressure warning light turns "ON." Press the pedal another eight to nine times.
7. Set pilot cutoff switch on "O" (OFF) position.
8. Turn key to "O" (OFF) position and remove from starter switch.
9. Remove accumulator by unscrewing it slowly.

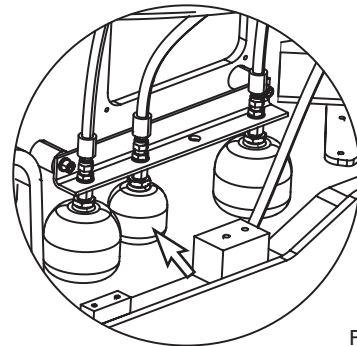

FG006227

Figure 107

# HYDRAULIC PRESSURE CHECKS

Hydraulic pressure for most systems can be checked by using the remote test ports shown in (Figure 108).

Reference Number	Description	Pressure
1	Main Pump Pressure (TPM)	200 $\pm$ 5 kg/cm <sup>2</sup>
2	Brake Charge Pressure (TP2)	120 kg/cm <sup>2</sup>
3	Steer Pump Pressure (TPS) at Only Steering Relief	220 $\pm$ 5 kg/cm <sup>2</sup>
4	Transmission Clutch Pressure (TM)	16 - 18 kg/cm <sup>2</sup>
5	Unloading Valve Pressure (TPU)	160 $\pm$ 5 kg/cm <sup>2</sup>
6	Control Lever Activation Pressure (TP1) at E/G High Idle	28 $\pm$ 2 kg/cm <sup>2</sup>

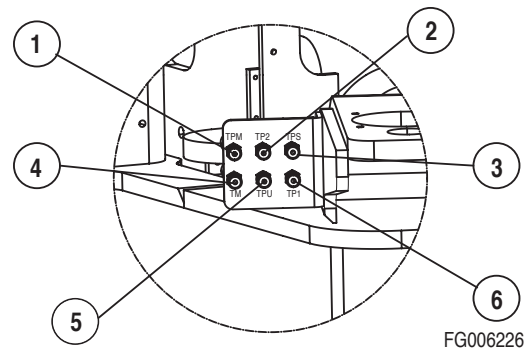

Figure 108

FG006226

## Control Valve Pressure

1. Attach gauge to port (1, Figure 108).
2. Relief valve cartridge on control valve (Figure 109) must be adjusted to open at 200  $\pm$ 5 kg/cm<sup>2</sup> (2,844  $\pm$ 70psi)

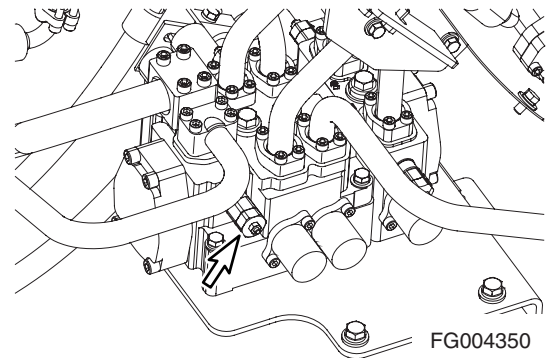

Figure 109

FG004350

## Brake Charge Pressure

1. Attach gauge to port (2, Figure 108).
2. Adjust relief valve cartridge on brake, pilot and fan motor supply valve (Figure 110). Relief pressure (Figure 110) for brake charging is  $120 \pm 5 \text{ kg/cm}^2$  ( $1,707 \pm 70 \text{ psi}$ ).

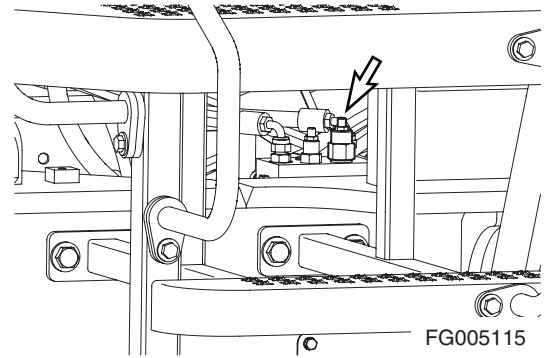

Figure 110

## Steering Pump Pressure

1. Attach gauge to port (3, Figure 108).
2. Adjust relief valve cartridge on EHPS valve (Figure 111). Cartridge must be adjusted to open at  $220 \pm 5 \text{ kg/cm}^2$  ( $3,130 \pm 70 \text{ psi}$ ).
3. Remove plastic plug Adjust screw that is beneath plug. Turn screw clockwise to raise relief pressure. Turn screw counterclockwise to lower relief pressure.
4. Install plastic plug after pressure has been adjusted.

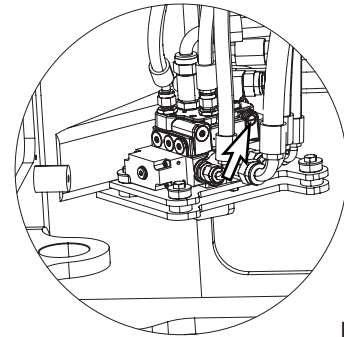

Figure 111

## Transmission Clutch Pressure

1. Attach gauge to port (4, Figure 108).
2. It is not impossible to adjust pressure.

**NOTE:** *Transmission clutch pressure is  $16^{+2}_0 \text{ kg/cm}^2$  ( $228^{+28}_0 \text{ psi}$ ).*

## Unloading Valve Pressure

1. Attach gage to port (5, Figure 108)
2. Relief pressure for unloading is  $160 \pm 5 \text{ kg/cm}^2$  ( $2,320 \pm 70 \text{ psi}$ ).
3. Adjust screw on unloading cartridge (C1) (Figure 108)
4. Loosen lock nut on adjusting screw. Turn adjusting screw clockwise to raise relief pressure. Turn adjusting screw counter clockwise to lower relief pressure.
5. Tighten lock nut after adjustment has been made.

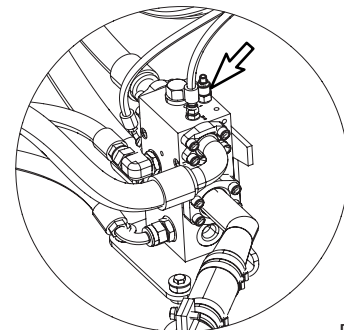

Figure 112

## Control Lever Activation Pressure

1. Attach gauge to port (5, Figure 108).
2. Adjust relief cartridge (Figure 113) on brake and pilot and fan motor supply valve. Relief pressure must be set at  $28 \pm 2 \text{ kg/cm}^2$  ( $398 \pm 28 \text{ psi}$ ).
3. Loosen lock nut on adjusting screw. Turn adjusting screw clockwise to raise relief pressure. Turn adjusting screw counterclockwise to lower relief pressure.
4. Tighten lock nut after adjustment has been made.

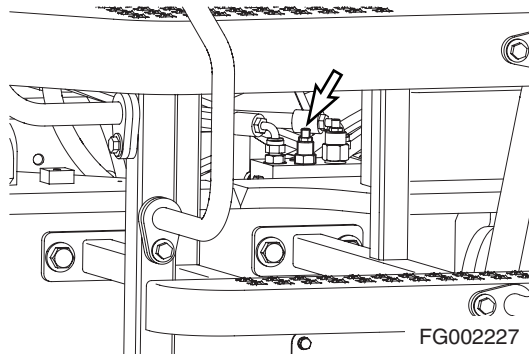

Figure 113

## Service Brake Outlet Pressure

1. Attach gauge to brake pressure test port (Figure 114) of front axle.
2. Outlet pressure must be  $60 \text{ kg/cm}^2$  ( $855 \text{ psi}$ ).

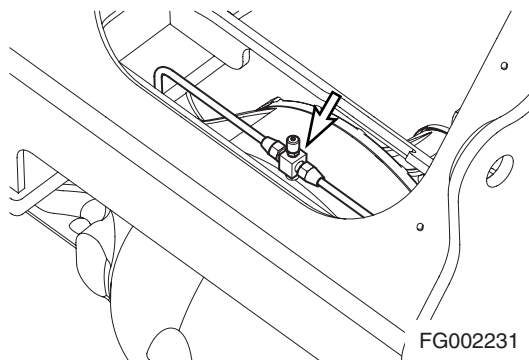

Figure 114

## Parking Brake Release Pressure

1. Attach pressure gauge to parking brake port.
2. Parking brake pressure must be  $70 - 120 \text{ kg/cm}^2$  ( $996 - 1,710 \text{ psi}$ ).

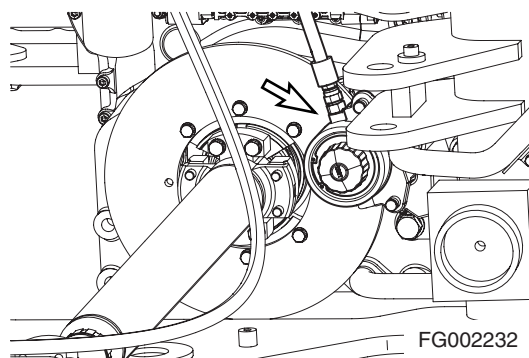

Figure 115

## Fan Motor Pressure and Fan rpm

The motor intergrates a proportional pressure relief valve, the fan speed (and thus the cooling performance) can be infinitely controlled depending on two different simultaneous input signals from temperature sensors.

The cooling fan controller processes the two input signals and controls the valve coil current. The proportional relief valve has a fail safe characteristic, this means, max. relief valve setting is adjusted automatically if the voltage supply is interrupted (e.g. broken wire). This results in a max. fan speed and therefore in a max. cooling performance.

Fan Motor Pressure	Standard
	90 ±5 kg/cm <sup>2</sup> (1,280 ±70 psi)
Fan rpm	1,200

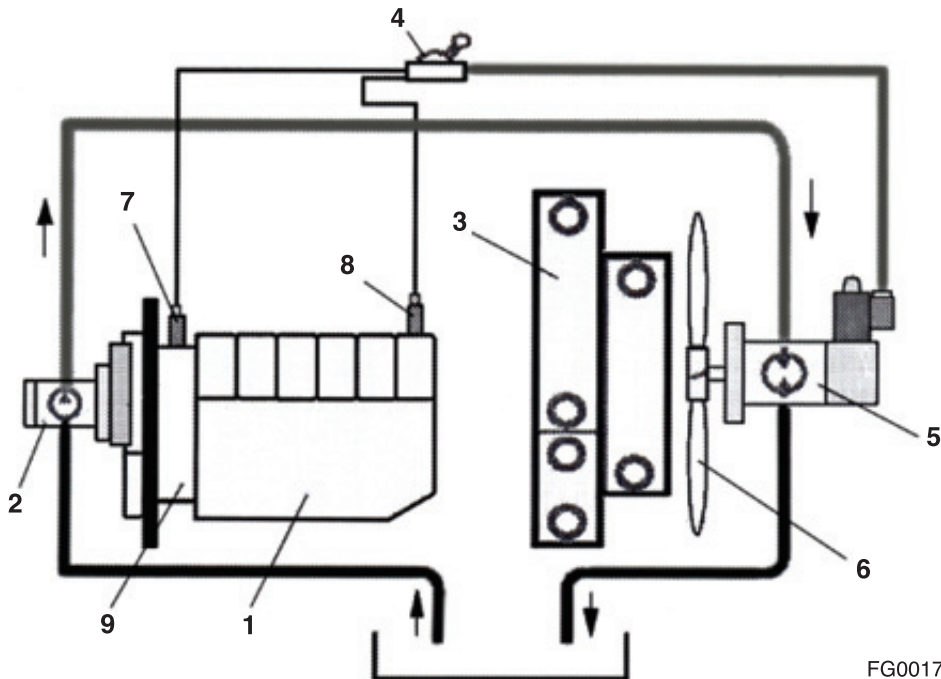

FG001746

Figure 116

Reference Number	Description
1	Engine
2	Cooling Pump
3	Cooler
4	Cooling Fan Controller
5	Fan Motor

Reference Number	Description
6	Cooling Fan
7	Temperature Sensor (T/M Oil)
8	Temperature Sensor (Coolant Water)
9	Transmission

# Checking the Relief Pressure of Fan Motor

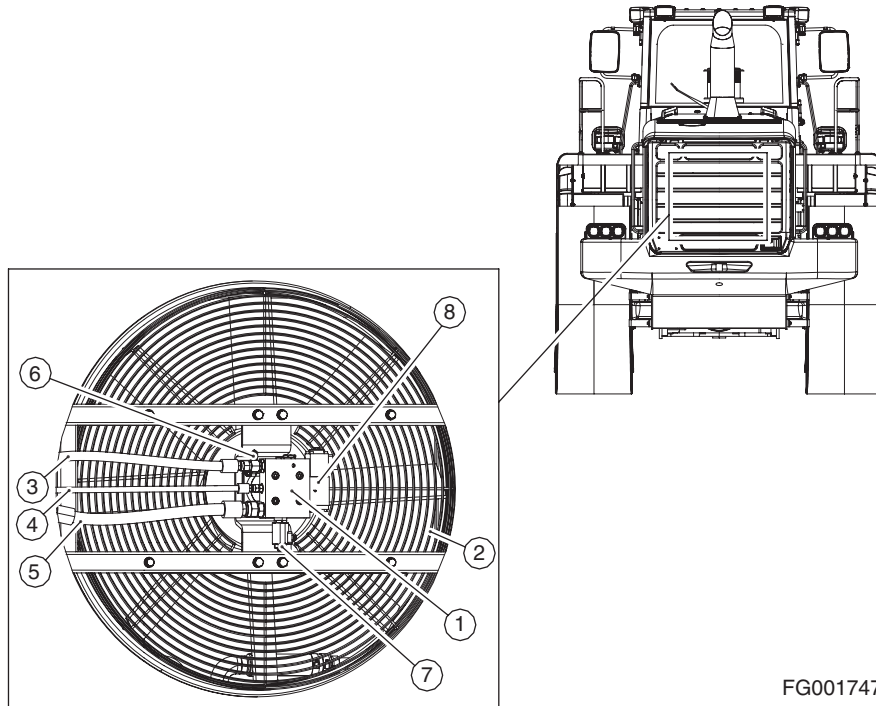

Figure 117

Reference Number	Description
1	Fan Motor
2	Fan Guard
3	Inlet Line
4	Drain Line

Reference Number	Description
5	Outlet Line
6	Relief Valve
7	Proportional Relief Valve
8	Reversible Solenoid Valve

## Maximum Fan Speed, Checking

1. Open the radiator grille in order to connect the pressure gauge.
2. Connect the pressure gauge to the pressure port (6) on the inlet hose (3). Check the maximum pressure by fully depressing the accelerator pedal and reading the pressure gauge. Maximum fan motor pressure:  $100 \pm 2$  kg/cm<sup>2</sup> (The fan speed is approximately 1200 rpm at this time)

# LONG TERM STORAGE

## Cleaning

Pressure wash machine. Inspect machine for any damage or missing parts. Drive machine to check steering linkage for damage.

## Hydraulic System

Start engine and allow it to idle for a few minutes. Drive machine around for two - three minutes. Raise and lower boom two - three times. Crowd and dump bucket two - three times. This will circulate hydraulic fluid through all hydraulic systems.

## Lubrication

Perform all daily maintenance procedures listed in this section (Section 4.) Grease all grease fittings in steering linkage. Apply a coating of light oil to all exposed cylinder rods. Apply a coating of light oil to all control linkages and all control valve spools. Check condition of oil coating each month and add to coating where necessary.

## Battery

Disconnect cables from battery, or remove battery from machine. If battery is removed, fully charge battery and store it.

## Cooling System Care

If cooling system does not need antifreeze and is filled with water only, add an anti-rust additive. If temperatures below freezing are expected, add antifreeze to protect system to level of cold expected. See antifreeze protection Table 4-1. Use a hydrometer to check level of antifreeze protection once each month. If desired, cooling system can be completely drained. If system is drained, place a sign in operator's cabin to warn operator that there is no coolant in engine.

# PARKING BRAKE ADJUSTMENT

## Emergency Release of the Parking Brake

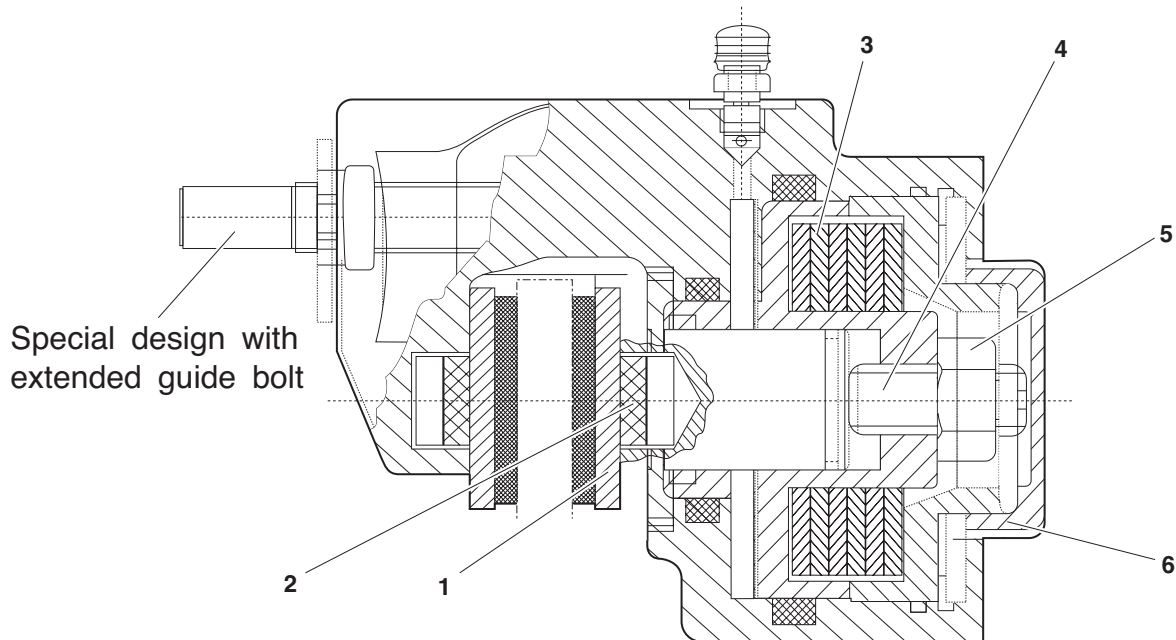

FG008053

**Figure 118**

If the parking brake cannot be released by normal hydraulic system pressure, or if the engine will not start, it must be manually released before towing can take place.

1. Before releasing parking brake make sure that wheels have wheel chocks placed in front of and behind them, to prevent machine from moving when parking brake is released.

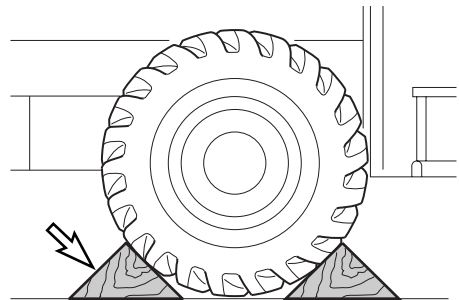

2876A

**Figure 119**

2. Release the screw cap (6, Figure 112) and unscrew.
3. Release the lock nut (5, Figure 112) and turn the adjusting screw (4) counterclockwise until the brake disk is free.
4. Install lock nut (5, Figure 112) and screw cap (6) and tighten both as far as possible. This will protect the parking brake assembly from dirt.

**NOTE:** Now, the vehicle does not have any brake function. The vehicle must be secured against moving away with proper means. Before putting the vehicle into operation again, the brake has to be adjusted according to adjusting regulations.

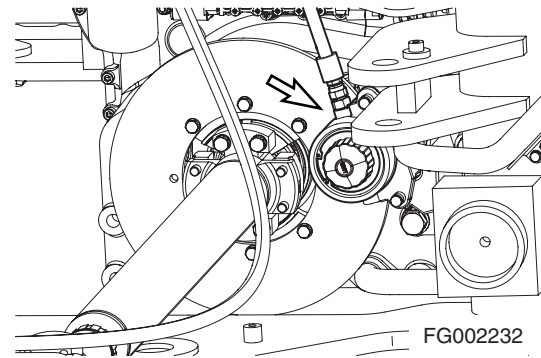

**Figure 120**

## Adjusting regulations

During this adjusting process, the parking brake must be released, i.e. the bank of cup springs (3, Figure 112) must be completely pretensioned.

1. Park vehicle on an even surface and place wheel chocks in front of and behind tires. Only then release the parking brake.
2. Release the screw cap (6, Figure 112) and unscrew.
3. Release the lock nut (5, Figure 112) (size 24 or 30) and turn the adjusting screw (4) with socket wrench (size 8 or 10) clockwise until the two brake pads (1) and (2) make contact with the brake disk.
4. Turn the adjusting screw (4, Figure 112) counterclockwise and set the clearance specified in the following table.

Type	Adjusting Screw	Clearance (mm)		Revolutions
		min.	max	
Small	M 16 (size 8)	min.	0.5	1/4
		Rated clearance	1.0	1/2
		max	1.5	3/4
Large	M 20 (size 10)	min.	1.0	2/5
		Rated clearance	2.0	4/5
		max	3.0	1 1/5

5. Hold the adjusting screw (4, Figure 112) in position with the hexagonal socket wrench and lock with the lock nut (5).
6. Mount the screw cap (6, Figure 112) and tighten as far as possible manually.
7. Actuate the brake valve several times and check the braking efficiency of the parking brake on slope.

# TIRES

## Inflating Tires

Recommended tire pressures should normally be followed. Special operations may justify a different pressure. In such cases, follow the instructions from the tire manufacturer and do not exceed the maximum permissible pressures, (See page 4-88)

The tire pressure may have been raised before the machine was delivered from the factory. Therefore, check and adjust the tire pressure according to recommendations, before putting the machine to work for the first time.



## **WARNING!**

---

**Repair work on tires and rims must be carried out by persons who have been especially trained for this.**

**The instructions stated below apply to an inflated tire where the pressure needs to be increased. If the tire has lost all pressure, a trained service engineer must be called in.**

---

- When checking the air pressure, the tire must be cold and the machine not have a load.
- Ask all other persons to leave the danger area (in front of the rim).
- Stand by the tire tread as shown in the figure. Tire installed on a split rim may explode causing injury or in the worst case death.
- Use a long air hose (with a self attaching air chuck) which allows you to stand outside the danger area.
- Tires on stored wheels (spare wheels) must be kept laying down on their side, and only be inflated sufficiently to keep the rim parts in position.

## Wheel Nut, Tightening Check

After having changed a tire or if the wheel has been removed and installed for any other reason, the wheel bolts must be check for tightness after eight hours of operation.

Tighten wheel nuts to 85 kg·m (615 ft lb).

## Wheel Nut Torque

Tighten wheel nuts to 85 kg·m (615 ft lb).



### WARNING!

---

If a wheel and tire must be removed from machine and replaced, or if a tire must be replaced on wheel, allow this task to be performed only by experienced service personnel. A tire rim could be propelled off wheel and cause serious bodily injury or death. See Figure 121.

---

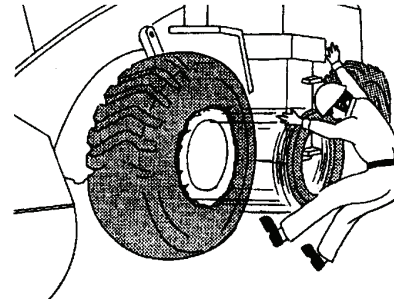

Figure 121

2853A

## Check Tire for Damage



### WARNING!

---

Improper servicing or changing tires and rims can cause explosion resulting in serious injury or death.

Do not service or change tires and rims unless properly trained and equipped.

Contact your nearest *DOOSAN* loader dealer or tire manufacturer's local dealer for tire servicing or changing.

---



### WARNING!

---

An overheated tire may explode causing serious injury or death.

If overheated tire is suspected, do not approach tire to distance of less than 15 m (50 ft).

Stay away until tire and rim cool down.

---

If the following defects are found in tires, for safety reasons the tires must be replaced with new tires.

For the replacement contact *DOOSAN* loader dealer or a tire manufacturer's local dealer.

- Bead wire is broken or bent, or the tire is greatly deformed.
- Wear is excessive and the carcass ply (including breaker) is exposed for more than 1/4 of the circumference.
- Damage to the carcass exceeds 1/3 of the tire width.

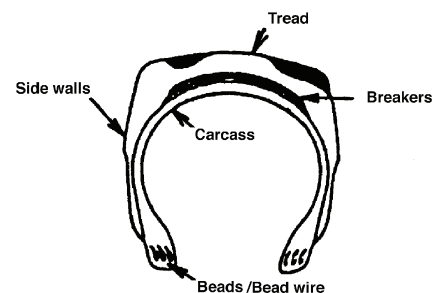

Figure 122

AHO0730S

- Tire layers are separated.
- Radial cracks reach the carcass.
- Deformation or damage which makes the tire unsuitable for use.

## Recommended Air Pressure

Tires	Working Pressure		Driving Pressure		Remarks
	Front	Rear	Front	Rear	
Bias Ply Tire	4.1 <sup>+0.1</sup> <sub>+0</sub> Bar (60 <sup>+2</sup> <sub>+0</sub> psi)	3.5 <sup>+0.1</sup> <sub>+0</sub> Bar (50 <sup>+2</sup> <sub>+0</sub> psi)	4.1 <sup>+0.1</sup> <sub>+0</sub> Bar (60 <sup>+2</sup> <sub>+0</sub> psi)	3.5 <sup>+0.1</sup> <sub>+0</sub> Bar (50 <sup>+2</sup> <sub>+0</sub> psi)	20.5-25-16PR (Standard)
Radial Ply Tire	3.5 <sup>+0.1</sup> <sub>+0</sub> Bar (50 <sup>+2</sup> <sub>+0</sub> psi)	3.0 <sup>+0.1</sup> <sub>+0</sub> Bar (44 <sup>+2</sup> <sub>+0</sub> psi)	3.5 <sup>+0.1</sup> <sub>+0</sub> Bar (50 <sup>+2</sup> <sub>+0</sub> psi)	3.0 <sup>+0.1</sup> <sub>+0</sub> Bar (44 <sup>+2</sup> <sub>+0</sub> psi)	20.5R25 (Option)

The recommended tire pressures are based on the rated load for each handling case.

In case of heavier loads, especially during loading and carrying operations, a higher tire pressure is required. Contact the tire manufacturer for information about which air pressure is the correct one for the load to be handled and transported over a particular distance.

If L5 tires are used for loading and carrying operations, due attention must be paid to the transporting distances. Radial tires are to be preferred for loading and carrying operation, as the buildup of heat is less in this type of tire.

# Transportation

## LOADING AND UNLOADING

When transporting the machine observe the various road rules, road transportation vehicle laws and vehicle limit ordinances, etc.

It is a good idea to obtain special platform for loading and unloading the machine.

1. Park the trailer on a flat firm roadbed. Keep a fairly long distance between the road shoulder and the machine.
2. Properly apply the brakes of the trailer and place wheel chocks in front of and behind the tires to ensure that the trailer does not move.
3. Fix the ramp in line with the centers of the trailer and the machine.
4. Determine the position of the ramp, then slowly load the machine onto to the specified part of the trailer.

**NOTE:** *Have someone in clear view and in a safe position, provide directions while loading.*

5. Lower the bucket and lock each control lever using the pilot cutoff switch.
6. Apply the parking brake and set the articulation stopper in the "LOCKED" position.
7. Tape over the exhaust stack outlet to prevent turbo "Windmilling" damage.
8. Place blocks in front of and behind the tires to prevent the machine from moving.
9. Fasten the machine to the trailer with chains or cables at lower part of the rear chassis. Additional chains or cables may be used but do not damage brake lines or cylinder rods.

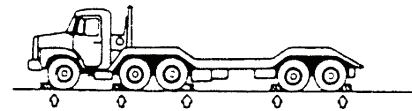

Figure 1

2880A

---

## IMPORTANT

---

**Brake pipe runs on axle housing.**

**Do not fasten axle housing.**

---

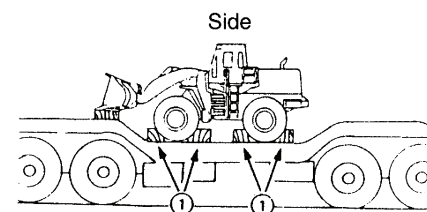

Figure 2

2882A

10. Determine the route for transporting the machine by taking into account the width, height and weight of the machine and the truck.

## SUMMARY OF SAFETY PRECAUTIONS FOR LIFTING

To make safe lifts, the following items must be evaluated by operator and work site crew.

- Condition of ground support.
- Wheel loader configuration and attachments.
- Weight, lifting height and lifting radius.
- Safe rigging of load.
- Proper handling of suspended load.

Tag lines on opposite sides of load can be very helpful in keeping a suspended load secure, if they are anchored safely to control points on ground.

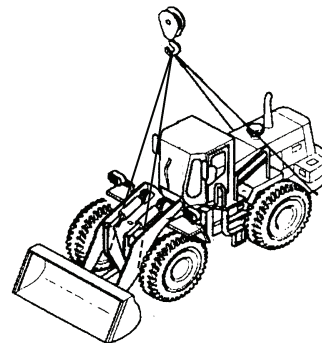

**Figure 3**

HAOJ581S

# Troubleshooting

## ENGINE

Problem	Possible Cause	Remedy
Starter does not operate.	Blown fuse.	Replace fuse.
	Low battery power.	Charge battery.
	Poor terminal contact.	Clean and tighten connections.
	Starter switch failed.	Replace switch.
	Starter relay failed.	Replace relay.
	Starter control failed.	Replace controller.
	Wiring harness faulty.	Replace harness.
	Battery relay failed.	Replace relay.
Starter engages, engine does not start.	Blown fuse.	Replace fuse.
	Fuel gelled in cold weather.	Replace fuel.
	Fuel filters plugged.	Replace filters.
	Water or dirt in fuel system.	Clean system and add new fuel.
	Air in fuel system.	Purge air from system.
	Engine stop control failed.	Replace stop control.
	Engine stop relay failed.	Replace relay.
Engine starts, runs only at low speed or shuts down.	Engine oil viscosity incorrect.	Change oil.
	Clogged or dirty fuel injectors.	Clean injectors.
	Fuel filters plugged.	Replace filters.
	Engine stop motor cable out of adjustment.	Readjust.
	Engine speed control cable out of adjustment.	Readjust.
Engine knocks, runs unevenly or surges.	Low engine oil.	Add oil.
	Plugged air intake system.	Clean system and replace filter.
	Injection pump out of adjustment.	Contact your <i>DOOSAN</i> dealer.
	Plugged fuel filter.	Replace fuel filter.
	Water or dirt in fuel system.	Clean system and add new fuel.
	Clogged or dirty fuel injectors.	Clean injectors.

<b>Problem</b>	<b>Possible Cause</b>	<b>Remedy</b>
Engine has poor power.	Plugged air intake system.	Clean system and replace filter.
	Clogged or dirty fuel injectors.	Clean injectors.
	Fuel filters plugged.	Replace filters.
	Engine speed control cable out of adjustment.	Readjust.
	Injection pump out of adjustment.	Contact your <i>DOOSAN</i> dealer.
	Valve backlash faulty.	Adjust backlash.
Engine runs hot.	Low coolant level.	Add coolant.
	Thermostat faulty.	Replace thermostat.
	Radiator cap faulty.	Replace radiator cap.
	Radiator core plugged.	Clean oil cooler.
	Oil cooler core plugged.	Clean oil cooler.
	Fan belt loose or damaged.	Tighten or replace as required.
	Temperature sensor faulty.	Replace sensor.
Engine oil pressure warning light turns "ON," and buzzer sounds.	Low engine oil level.	Add oil.
	Wrong grade oil for weather conditions.	change oil.
	Clogged oil filter.	Change filter and oil.
	Defective alarm switch.	Contact your <i>DOOSAN</i> dealer.
	Oil leakage from pipe or joint.	
	Clogged suction strainer.	
	Excessive engine wear.	
	Defective oil pump.	
Coolant temp, warning light turns "ON."	Low engine coolant level.	Add coolant.
	Loose/slipping/broken fan belt.	Adjust or replace belt.
	Clogged radiator fins.	Clean.
	Scale or mineral build up inside radiator.	Flush or professionally clean.
	Defective alarm switch (gauge is in green).	Contact your <i>DOOSAN</i> dealer.
	Low water pump flow.	
	Thermostat stuck or missing.	
Engine does not start when the starter motor is turning. (Also see ELECTRICAL TROUBLESHOOTING.)	Fuel filter clogged.	Replace fuel filter.
	Starter motor speed too low.	Booster Battery may be used.
	Defective engine shutoff solenoid.	Contact your <i>DOOSAN</i> dealer.
	Fuel pump failure.	
	Incorrect fuel injection timing.	
	Compression pressure too low.	
	Defective injectors.	

<b>Problem</b>	<b>Possible Cause</b>	<b>Remedy</b>
Unstable (rough) idling.	Air in fuel lines.	Tighten fuel connections and filter.
	Fuel filter clogged.	Replace fuel filter.
	Fuel pump failure.	Contact your <i>DOOSAN</i> dealer.
	Incorrect fuel injection timing.	
Insufficient power.	Air cleaner filter clogged.	Clean or replace element.
	Fuel filter element clogged.	Replace fuel filter.
	Throttle linkage adjustment wrong.	Check and adjust linkage.
	Engine oil level too high.	Check dipstick and correct level.
	Incorrect valve clearance.	Contact your <i>DOOSAN</i> dealer.
	Piston ring wear.	
	Defective injectors.	
	Fuel pump failure.	

## HYDRAULIC SYSTEM

<b>Problem</b>	<b>Possible Cause</b>	<b>Remedy</b>
None of the controls function (loud noise from pumps).	Hydraulic pump failed.	Contact your <i>DOOSAN</i> dealer.
	Low hydraulic oil level.	Add hydraulic oil as required.
	Suction line plugged or damaged.	Clean or replace as required.
None of the controls function (no noise from pumps).	Pilot pump failure.	Contact your <i>DOOSAN</i> dealer.
	Cutoff solenoid valve failed.	Replace solenoid.
	Relief cartridge of pilot parking valve stuck.	Clean or replace as required.
	Safety limit switch is ON.	Adjust limit switch clearance.
All actuators have low power.	Low hydraulic oil level.	Add hydraulic oil as required.
	Suction filter clogged.	Clean filter.
	Hydraulic pumps faulty.	Contact your <i>DOOSAN</i> dealer.
	Main relief pressure too low.	Contact your <i>DOOSAN</i> dealer.
	Hydraulic pumps cavitating.	Bleed air from hydraulic pumps.

<b>Problem</b>	<b>Possible Cause</b>	<b>Remedy</b>
Only one or two actuators have little or no power.	Overload relief pressure too low.	Reset pressure.
	Makeup check valve leaking.	Clean or replace as required.
	Control valve spool faulty.	Replace valve spool.
	Dirt in valve spool.	Clean or replace as required.
	Actuator failed.	Repair or replace as required.
	Cylinder seal failed.	Repair or replace as required.
	Cylinder rod damaged.	Repair or replace as required.
	Remote control valve failed.	Replace control valve.
	Wrong pilot line connection.	Reconnect pilot lines.
Oil temperature too high.	Debris in exterior of cooler.	Clean exterior of cooler.
	Oil cooler faulty.	Contact your <i>DOOSAN</i> dealer.
	Fan belt loose.	Tighten fan belting as required.
Actuators on one side of boom have little power or do not operate.	Overload relief valve is not operating properly.	Repair valve or replace.
	Damaged hydraulic hose.	Replace hose.
	Loose hydraulic fittings.	Tighten fittings.
	Internal damage to control valve housing.	Replace control valve.
	Control valve spool damaged.	Replace control valve.
	Sediment inside control valve.	Clean and repair valve.
	Check valve internal leakage.	Repair or replace valve.
	Damaged cylinder or pump.	Repair or replace pump or cylinder.
	Cylinder internal leakage.	Repair or replace cylinder.
	Damaged cylinder rod.	Replace rod.
Pilot valve failure.	Replace pilot valve.	

# TRAVEL SYSTEM

## General

Problem	Possible Cause	Remedy
Machine will not travel.	Transmission clutch pressure incorrect.	Adjust pressure.
	Transmission charge pump damaged.	Replace pump.
	Damage to transmission control valve wiring harness.	Repair wiring.
	Burned travel relay or fuse.	Replace relay or fuse.
	Forward/Reverse solenoid for transmission control valve sticking.	Clean and repair.
	Damaged transmission clutch.	Repair or replace clutch.
	Damaged drive shaft.	Repair or replace.
	Damaged transmission or axle.	Repair or replace.
	Wheel brakes not releasing.	Repair brakes.
	Parking brake not releasing.	Repair parking brake.
Machine will travel but has little power.	Fluid pressure low in transmission clutch.	Repair clutch.
	Transmission fluid low.	Add fluid.
	Damage to torque converter.	Repair or replace.
	Engine malfunction.	See Engine Troubleshooting Table.
	Brake valve.	Disassemble and clean.
Unusual transmission noise.	Low transmission fluid, or low quality fluid.	Add fluid or change fluid.
	Worn transmission parts.	Replace parts.
	Broken gears or bearings.	Replace parts.
Transmission fails to operate.	Damaged transmission clutch disks.	Replace disks.
	Damaged wires in transmission control wire harness.	Repair wires.
Drive shaft vibration Noisy universal joints.	Bent drive shaft.	Replace drive shaft.
	Loose universal joints.	Tighten bolts that secure joints.
	Worn or damaged universal joint.	Replace universal joint.
	Loose universal joints.	Tighten bolts that secure universal joints.
	Lack of lubrication.	Lubricate universal joints.
	Worn slip joint spline.	Replace slip joint.
Noisy Front or Rear Axle.	Worn or broken gears.	Replace gears.
	Low oil level, poor quality oil.	Add oil, change oil.
	Worn bearings.	Replace bearings.
	Worn shaft spline.	Replace spline.

# STEERING

Problem	Possible Cause	Remedy
Steering Wheel is hard to turn.	Sediment blocking direction change spool orifice, inside priority valve.	Clean and repair.
	Sediment blocking amplifying spool orifice, inside priority valve.	Clean and repair.
	Sediment blocking load sensing line orifice, inside priority valve.	Clean and repair.
	Priority valve spool sticking, inside steering valve.	Clean and repair.
	Incorrect relief valve pressure drop, inside priority valve.	Adjust pressure.
	Steering pump failure.	Repair or replace.
	Leaking steering cylinder.	Repair cylinder.
	Rust on steering column bearing and spline.	Lubricate.
	Tire air pressure is low.	Inflate to proper pressure.
High initial resistance to movement of steering wheel.	Air in load sensing line, inside priority valve.	Bleed system to remove air.
	Sediment blocking orifice of load sensing line, inside priority valve.	Clean and repair.
	Sediment in direction change spool, inside priority valve.	Clean and repair.
	Damage to control spring damping inside priority valve.	Replace priority valve.
Steering wheel shakes.	Chattering bearing in axle end differential.	Replace bearing.
	Tire pressure not equal in left side and right side tires.	Equalize pressure.

# BRAKING

Problem	Possible Cause	Remedy
Reduced brake action.	Low secondary pressure in brake valve.	Repair or replace brake valve.
	Worn brake disks.	Replace brake disks.
	Damaged brake disks.	Replace brake disks.
	Damaged brake valve block.	Replace valve.
	Air in brake hydraulics due to leak in brake hose.	Repair leak, bleed system.
After bleeding brakes, brakes are not fully released.	Damaged brake disks.	Replace disks.
	Damaged brake disk return spring.	Replace return springs.

# ELECTRICAL SYSTEM

Problem	Possible Cause	Remedy
Battery has no power and will not accept a charge.	Damaged battery plates.	Replace battery.
	Alternator not charging properly.	Repair or replace alternator.
	Bad ground.	Clean and tighten.
	Loose electrical connector.	Clean and tighten.
	Alternator belt loose or damaged.	Tighten or replace.
Battery will accept a charge but discharges soon after.	Internal battery short.	Replace battery.
	Wiring harness short.	Repair wire.



# Specification

## GENERAL SPECIFICATIONS

DL250	
ITEM	SPECIFICATION
Standard Bucket Capacity (BOT / BOC)	2.5 m <sup>3</sup> (3.25 yd <sup>3</sup> ) / 2.6 m <sup>3</sup> (3.38 yd <sup>3</sup> )
Vehicle Weight	14,000 kg (30,864 lb) - standard
Engine (SAE J1995 Gross)	
Emission	U.S EPA Tier3 (EU Stage IIIA)
Maker and Model	DOOSAN DL06
Type	Turbo Charged, Air to Air Intercooled Direct Injection
Injection System	Common-rail Controlled by Electronic ECM
Max. Horse Power	172 ps (127 kw) / 1800 rpm
Rated Horse Power	165 ps (121 kw) / 2100 rpm
Max. Torque	82 kg·m (804 N.m) / 1400 rpm
Transmission	
Full Automatic Power -Shift	Full Automatic Power Shift
Speeds	4 Forward, 3 Reverse
Brake Systems	
Travel Brakes	4 Wheel, Wet Disk (Sinter Metal Disk)
Parking Brake	SAHR, Dry Disk Type
Performance	
Travel Speed	6.6 (4.1) / 11.5 (7.1) / 22.5 (14) / 34 (21) km/h (MPH)
Steering Angle	±40°
Min. Tire Turning Radius (Out Tire Edge)	5,450 mm (17' 10")
Safe Operating Load	4,320 kg (9,523 lb)
Max. Breakout Force	13,200 kg (29,100 lb)
Boom Rise Time	5.4 ±0.5Sec.
Bucket Dump Time	1.3 ±0.3 Sec.
Boom Down Time	3.3 ±0.4 Sec.
Maximum Gradeability	30° (58%)

# WORKING RANGE AND DIMENSIONS

Figure 1, illustrates exterior machine dimensions and working range of machine when it is equipped with a standard bucket.

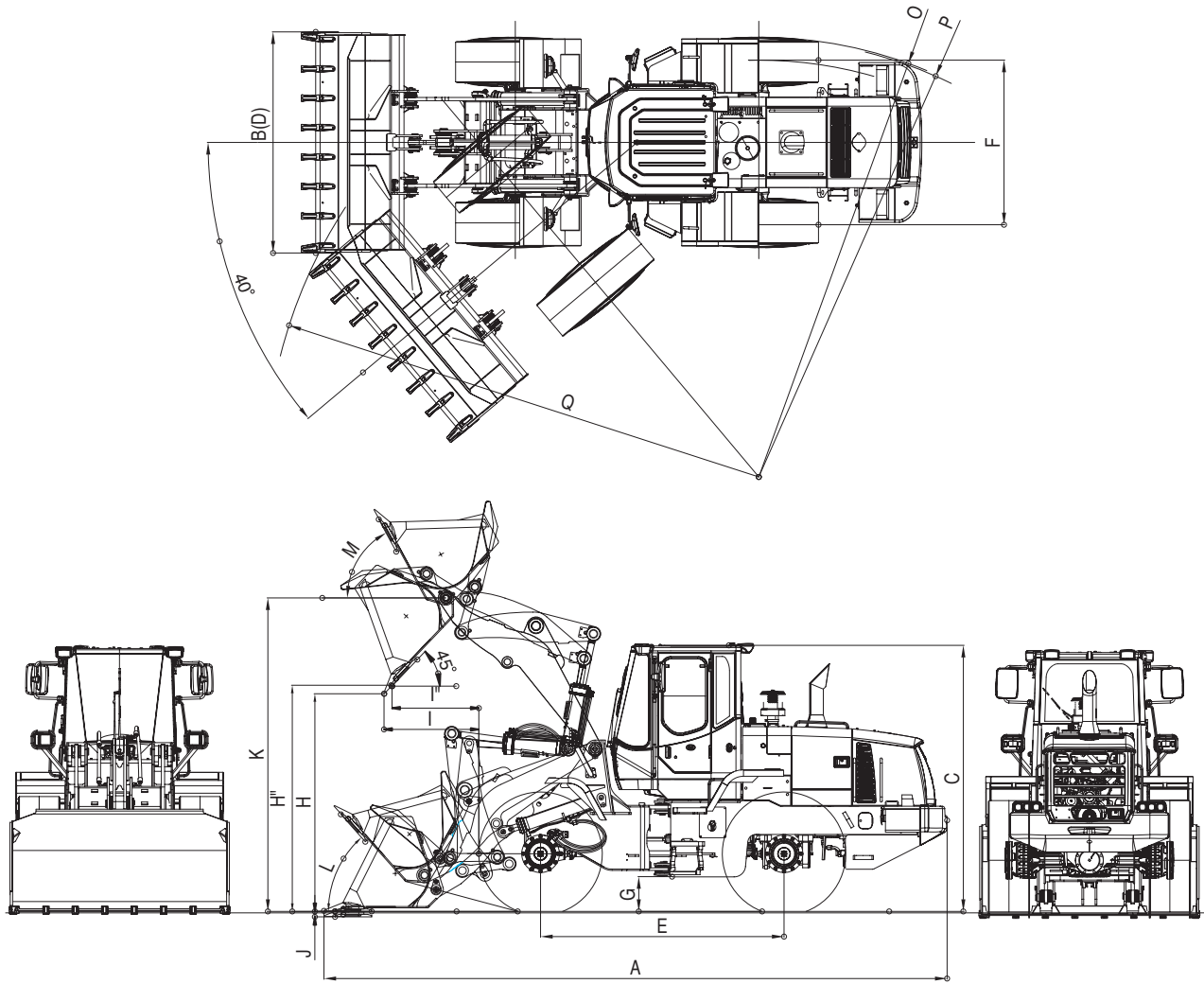

FG006688

Figure 1

CATEGORY		DIMENSION	
Tire Size		20.5-25-16PR (L3)	20.5R25 (L3)
Overall Length (A)		7,694 mm (25' 3")	
Overall Width (B)		2,740 mm (9')	
Overall Height (C)		3,290 mm (10' 10")	3,260 mm (10' 8")
Bucket Width (D)		2,740 mm (9')	
Wheel Base (E)		3,020 mm (9' 11")	
Tread (F)		2,040 mm (6' 8")	
Ground Clearance (G)		440 mm (1' 5")	410 mm (1' 4")
Dump Height, at 45° (with teeth) (H)		2,730 mm (8' 11")	2,700 mm (8' 10")
Dump Height, at 45° (without teeth, with extra blade) (H")		2,865 mm (9' 5")	2,835 mm (9' 4")
Dump Reach, at 45° (with teeth) (I)		1,200 mm (3' 11")	1,210 mm (3' 11")
Dump Reach, at 45° (under teeth, with extra blade) (I")		1,072 mm (3' 6")	1,088 mm (3' 7")
Digging Depth (J)		60 mm (2")	90 mm (4")
Bucket Hinge Height (K)		3,886mm (12' 9")	3,856mm (12' 8")
Max.Tilt Angle at Carry Position (L)		48°	
Max.Tilt Angle at Fully Raised (M)		62°	
Max.Dump Angle at Fully Raised (N)		46°	
Turning Radius	(Out Tire Edge) (O)	5,450 mm (17' 10")	5,477 mm (17' 11")
	(C/Weight Edge) (P)	5,430 mm (17' 10")	
	(Bucket Edge) (Q)	6,010 mm (19' 9")	

# WORKING CAPACITIES

## Bucket Capacity

Standard toothed bucket has a capacity of 2.5 m<sup>3</sup> (3.25 yd<sup>3</sup>).

## Tipping Load

Static Tipping Load with bucket in Over Front position is 12,200 kg (26,895 lb). With bucket in Fully Turned position, Static Tipping Load is 10,200 kg (22,486 lb).

## Material Weight

The data below describes weight of a cubic meter (cubic yard) of many types of workload materials.

# APPROXIMATE WEIGHT OF WORKLOAD MATERIALS

MATERIAL	LOW WEIGHT OR DENSITY 1,100 KG/M <sup>3</sup> (1,850 LB/YD <sup>3</sup> ), OR LESS	MEDIUM WEIGHT OR DENSITY 1,600 KG/M <sup>3</sup> (2,700 LB/YD <sup>3</sup> ), OR LESS	HIGH WEIGHT OR DENSITY 2,000 KG/M <sup>3</sup> (3,370 LB/YD <sup>3</sup> ), OR LESS
Charcoal	401 kg/m <sup>3</sup> (695 lb/yd <sup>3</sup> )	-----	-----
Coke, blast furnace size	433 kg/m <sup>3</sup> (729 lb/yd <sup>3</sup> )	-----	-----
Coke, foundry size	449 kg/m <sup>3</sup> (756 lb/yd <sup>3</sup> )	-----	-----
Coal, bituminous slack, piled	801 kg/m <sup>3</sup> (1,350 lb/yd <sup>3</sup> )	-----	-----
Coal, bituminous r. of m., piled	881 kg/m <sup>3</sup> (1,485 lb/yd <sup>3</sup> )	-----	-----
Coal, anthracite	897 kg/m <sup>3</sup> (1,512 lb/yd <sup>3</sup> )	-----	-----
Clay, DRY, in broken lumps	1,009 kg/m <sup>3</sup> (1,701 lb/yd <sup>3</sup> )	-----	-----

<b>MATERIAL</b>	<b>LOW WEIGHT OR DENSITY 1,100 KG/M<sup>3</sup> (1,850 LB/YD<sup>3</sup>), OR LESS</b>	<b>MEDIUM WEIGHT OR DENSITY 1,600 KG/M<sup>3</sup> (2,700 LB/YD<sup>3</sup>), OR LESS</b>	<b>HIGH WEIGHT OR DENSITY 2,000 KG/M<sup>3</sup> (3,370 LB/YD<sup>3</sup>), OR LESS</b>
Clay, DAMP, natural bed	-----	1,746 kg/m <sup>3</sup> (2,943 lb/yd <sup>3</sup> )	-----
Cement, Portland, DRY granular	-----	1,506 kg/m <sup>3</sup> (2,583 lb/yd <sup>3</sup> )	-----
Cement, Portland, DRY clinkers	-----	1,362 kg/m <sup>3</sup> (2,295 lb/yd <sup>3</sup> )	-----
Dolomite, crushed	-----	1,522 kg/m <sup>3</sup> (2,565 lb/yd <sup>3</sup> )	-----
Earth, loamy, DRY, loose	-----	1,202 kg/m <sup>3</sup> (2,025 lb/yd <sup>3</sup> )	-----
Earth, DRY, packed	-----	1,522 kg/m <sup>3</sup> (2,565 lb/yd <sup>3</sup> )	-----
Earth, WET, muddy	-----	-----	1,762 kg/m <sup>3</sup> (2,970 lb/yd <sup>3</sup> )
Gypsum, calcined, (heated, powder)	961 kg/m <sup>3</sup> (1,620 lb/yd <sup>3</sup> )	-----	-----
Gypsum, crushed to 3 inch size	-----	1,522 kg/m <sup>3</sup> (2,565 lb/yd <sup>3</sup> )	-----
Gravel, DRY, packed fragments	-----	-----	1,810 kg/m <sup>3</sup> (3,051 lb/yd <sup>3</sup> )
Gravel, WET, packed fragments	-----	-----	1,922 kg/m <sup>3</sup> (3,240 lb/yd <sup>3</sup> )
Limestone, graded above 2	-----	1,282 kg/m <sup>3</sup> (2,160 lb/yd <sup>3</sup> )	-----
Limestone, graded 1-1/2 or 2	-----	1,362 kg/m <sup>3</sup> (2,295 lb/yd <sup>3</sup> )	-----
Limestone, crushed	-----	1,522 kg/m <sup>3</sup> (2,565 lb/yd <sup>3</sup> )	-----
Limestone, fine	-----	-----	1,602 kg/m <sup>3</sup> (2,705 lb/yd <sup>3</sup> )
Phosphate, rock	-----	1,282 kg/m <sup>3</sup> (2,160 lb/yd <sup>3</sup> )	-----

MATERIAL	LOW WEIGHT OR DENSITY 1,100 KG/M <sup>3</sup> (1,850 LB/YD <sup>3</sup> ), OR LESS	MEDIUM WEIGHT OR DENSITY 1,600 KG/M <sup>3</sup> (2,700 LB/YD <sup>3</sup> ), OR LESS	HIGH WEIGHT OR DENSITY 2,000 KG/M <sup>3</sup> (3,370 LB/YD <sup>3</sup> ), OR LESS
Salt	929 kg/m <sup>3</sup> (1,566 lb/yd <sup>3</sup> )	-----	-----
Snow, light density	529 kg/m <sup>3</sup> (891 lb/yd <sup>3</sup> )	-----	-----
Sand, DRY, loose	-----	1,522 kg/m <sup>3</sup> (2,565 lb/yd <sup>3</sup> )	-----
Sand, WET, packed	-----	-----	1,922 kg/m <sup>3</sup> (3,240 lb/yd <sup>3</sup> )
Shale, broken	-----	1,362 kg/m <sup>3</sup> (2,295 lb/yd <sup>3</sup> )	-----
Sulphur, broken	529 kg/m <sup>3</sup> (1,620 lb/yd <sup>3</sup> )	-----	-----

---

## IMPORTANT

---

Weights are approximations of estimated average volume and mass. Exposure to rain, snow or ground water; settling or compaction due to overhead weight and chemical or industrial processing or changes due to thermal or chemical transformations could all increase value of weights listed in table.

---

# Index

## Numerics

1,000 Hour / 6 Month Service 4-53  
1,500 Hour / 9 Month Service 4-61  
12,000 Hour / Six Year Service 4-70  
2,000 Hour / Annually Service 4-64  
50 Hour / Weekly Service 4-35  
500 Hour / 3 Month Service 4-46

## A

Accelerator Pedal 2-9  
Accumulator 4-69, 4-77  
Air Conditioner  
    Filter 4-52, 4-58  
    Refrigerant - Check 4-58  
Air conditioner Condenser Cleaning 4-40  
Air Filter Indicator Light 2-19  
Air Intake System  
    Check Engine Air Precleaner 4-41  
    Inspection 4-34  
    Replace Outer Air Cleaner Element 4-54, 4-64  
Antifreeze Concentration Tables 4-76  
Applications 1-4  
Attachment Pins 4-35  
Attachment Precautions 1-20  
Auxiliary Batteries 3-8  
Axle  
    Differential 4-54  
    Oil Change 4-50  
Axle Differential 4-50

## B

Battery  
    Auxiliary Batteries 3-8  
    Condition 4-73  
    Long Term Storage 4-83  
    Warning Light 2-19  
Boom  
    Lower Kickout 3-19  
    Raise Kickout 3-18  
Boom Float Switch 2-36  
Brake  
    Charge Pressure 4-79  
Brake Pedal 2-10  
Brakes

Accumulator 4-69  
Bleeding 4-65  
Brake Fluid Warning 2-21  
Brake Fluid Warning Light 2-21  
Brake Pedal 2-10  
Troubleshooting 6-7

## Bucket

Angle Indicator 3-18  
Capacity 7-4  
Position Switch 3-19  
Teeth and Side Cutters 4-31

## C

Cab Light 2-42  
Capacities  
    Fluid 4-16  
Center Pins 4-39  
Cigar Lighter 2-29  
Circuit Breaker 2-59  
Clean Exterior of Radiator, Oil Cooler and Air  
    Conditioner Condenser 4-48  
Cold Weather Engine Start 3-5  
Combination Switch 2-8  
Component Locations 2-2  
Conditions - Severe Maintenance 4-86  
Conditions - Severe Maintenance 4-71  
Cooling System 4-75  
    Care 4-83  
    Coolant Level 4-30  
    Coolant Temperature Gauge 2-17  
    Radiator Coolant 4-66  
Cracks and Faulty Welds 4-31  
Cup Holder 2-38

## D

Dismounting and Mounting Machine 1-17  
Door Side Latch 2-55  
Drive Belt Wear 4-33  
Drive Shaft - Grease 4-43

## E

Electrical System 4-73  
    Box 2-43  
    Troubleshooting 6-7  
Emergency Steering Switch 2-37

## Engine

- Air Conditioner and Alternator Belt Tension 4-39, 4-42
- Check and Adjust 4-59
- Diagnostic Switch 2-35
- Drive Belt Wear 4-33
- Filter Change 4-51
- Oil and Filter 4-39
- Oil Change 4-51
- Oil Level Check 4-26
- Serial Number 4-13
- Start 3-2
- Stop 3-9
- Ventilation 1-21
- Warning Light 2-23

## F

- F/R (Forward/Reverse) Control Switch 2-39
- F/R (Forward/Reverse) Selector Switch 2-38
- Fan Blade Inspection 4-33
- Fluid Capacities 4-16
- Front Instrument Panel 2-15
- Front Work Light Switch 2-31
- Fuel System
  - Condensation - Draining 4-30
  - fill 4-29
  - Gauge 2-16
  - Leaks 4-30
  - Tank - Cleaning 4-57
- Fuse
  - Box One 2-44
  - Boxes 2-57
- Fusible Link 2-60

## G

### Gauges

- Coolant Temperature 2-17
- Fuel Gauge 2-16
- Hour Meter 2-16
- Speedometer 2-16
- Tachometer 2-17
- Transmission Oil Temperature 2-17

## H

- Headlight Switch 2-31
- Heater and Air Conditioner
  - Additional Operating Instruction 2-49
  - Blower Fan Switches 2-47
  - Fan and Air-Conditioner Switch 2-46
  - Memory Function of Used Mode 2-49
  - Selection Switch for Wind Direction 2-47
  - Temperature Control Switch 2-47
  - Ventilation Selection Switch 2-48
- Heater and Air Conditioner Operation 2-45

- High Beam Indicator Light 2-20
- Horn Button 2-7, 2-29
- Hour Meter 2-16
- Hydraulic Oil Tank
  - Drain Water 4-41
- Hydraulic System
  - Check Oil Level 4-28
  - Control Lever Activation Pressure 4-80
  - Fan Motor Pressure 4-82
  - Full Flow Filter - Replace 4-39, 4-60
  - Hydraulic Pressures 4-78
  - Leaks in the Hydraulic System 4-29
  - Long Term Storage 4-83
  - Service Brake Outlet Pressure 4-80
  - Steering Pump Pressure 4-79
  - System Pilot Filter - Replace 4-46
  - System Warm-up 3-10
  - System Warm-up - Cold Weather 3-10
  - Transmission Clutch Pressure 4-79
  - Troubleshooting 6-3

## I

### Indicator Lights

- Air Filter Indicator Light 2-19
  - Battery Warning Light 2-19
  - Brake Oil Pressure Warning Light 2-21
  - Emergency Steering Indicator Light 2-22
  - Engine Maintenance Lamp 2-23
  - Engine Stop Lamp 2-23
  - Engine Warning Light 2-23
  - High Beam Indicator Light 2-20
  - Left Turn and Hazard Warning Light 2-20
  - Parking Brake Indicator Light 2-22
  - Preheat Cycle Indicator Light 2-19
  - Right Turn and Hazard Warning Light 2-20
  - Work Light Indicator Light 2-21
- Inner Air Cleaner Element 4-64
- Inspection, Maintenance and Adjustment 4-1
- Instrument Panel Monitoring System 3-1

## K

- Kick-down Switch 2-11, 2-28

## L

- Leaks in Fuel System 4-30
- Leaks in Hydraulic System 4-29
- Left Turn and Hazard Warning Light 2-20
- Levers
  - Adjusting Seat Forward/Backward 2-52
  - Adjusting Seat's Angle 2-52
  - Angle Adjustment of Armrest 2-53
  - Backrest Adjustment 2-52
  - Log Forks Control Lever 2-26
  - Transmission Lever 2-12

Weight Adjustment Knob 2-52  
Lifting Safety Precautions 5-2  
Loading and Unloading 5-1  
Log Fork Control Lever 2-26  
Long Term Storage 4-83  
Lubricants 4-14  
Lubrication and Service Chart 4-22

## **M**

Machine  
    Shutdown 3-14  
    Travel 3-11  
Machine Serial Number 4-12  
Maintenance 1-34  
Maintenance Intervals 4-24  
Material Weight 7-4  
Mounting and Dismounting 1-17

## **N**

New Machine Break-in Procedures 3-1

## **O**

Operation 1-26, 3-1  
Operational Controls and Panels 2-5  
Operator's Area 2-4  
Outer Air Cleaner Element 4-54

## **P**

Parking Brake  
    Adjustment 4-84, 4-85  
    Emergency Release 4-84  
    Release Pressure 4-80  
Parking Brake Indicator Light 2-22  
Parking Brake Switch 2-33  
Parking Machine 1-32  
Pilot Cut-off Switch 2-33  
Planetaries 4-50, 4-61  
Power Socket 2-38  
Preheat Cycle Indicator Light 2-19  
Preventive Maintenance 4-1

## **R**

Radio  
    Speaker 2-43  
Rear Wiper Switch 2-32  
Rear Work Light Switch 2-32  
Regulations, Local 1-30  
Relay 2-59  
Right Turn and Hazard Warning Light 2-20  
Rotating Light (Beacon) 2-38

## **S**

Safety

Label Locations 1-4  
Safety Precautions 4-13  
Seat Adjustment  
    Adjusting Seat Forward/Backward 2-52  
    Adjusting Seat's Angle 2-52  
    Angle Adjustment of Armrest 2-53  
    Backrest Adjustment 2-52  
    Headrest 2-53  
    Weight Adjustment 2-52  
Seat Belt 2-54  
Seat Belt Inspection 4-31  
Serial Numbers 4-12  
Shipping and Transportation 1-48  
Shutdown  
    Engine Stop 3-9  
    Machine 3-14  
    Shutdown Control Functions 1-33  
Sloping Terrain 1-27  
Speakers 2-43  
Speedometer 2-16  
Starter Switch 2-6  
Start-up  
    Cold Weather Engine Start 3-5  
    Engine Start 3-2  
    Hydraulic System Warm-up 3-10  
    Hydraulic System Warm-up – Cold Weather 3-10  
Steering  
    Troubleshooting 6-6  
    Wheel 2-10  
Switch Panel 2-25  
Switches  
    Blower Fan Switches 2-47  
    Combination Switch 2-8  
    Emergency Steering Switch 2-37  
    F/R (Forward/Reverse) Control Switch 2-39  
    F/R (Forward/Reverse) Selector Switch 2-38  
    Front Work Light Switch 2-31  
    Headlight Switch 2-31  
    Heater and Air Conditioner Fan Switch 2-46  
    Heater and Air Conditioner Selection Switch for Wind Direction 2-47  
    Heater and Air Conditioner Ventilation Selection Switch 2-48  
    Horn Button 2-7  
    Kick-down Switch 2-11, 2-28  
    Parking Brake Switch 2-33  
    Pilot Cut-off Switch 2-33  
    Power Socket 2-38  
    Rear Wiper Switch 2-32  
    Rear Work Light Switch 2-32  
    Rotating Light (Beacon) 2-38  
    Starter Switch 2-6  
    Temperature Control Switch 2-47  
    Transmission Cut-off Switch 2-34

Switches and Levers  
  Boom Float Switch (option) 2-36  
  Engine Diagnostic Switch 2-35

## **T**

Tachometer 2-17  
Tipping Load 7-4  
Tire Damage 4-87  
Tire Pressure Inspection 4-26  
Towing Machine 3-20  
Transmission  
  Cut-off Switch 2-34  
  Display 2-15  
  Lever 2-12  
  Oil - Drain and Replace 4-43, 4-55  
  Oil Filter Replacement 4-43, 4-55  
  Oil Level Check 4-27  
  Oil Temperature Gauge 2-17  
Transportation 5-1  
Travel  
  Precautions 1-27

Travel System  
  Troubleshooting 6-5

## **U**

Unauthorized Modifications 1-13  
Unloading and Loading 5-1

## **V**

Vibration 2-53  
Vibration Level 1-15  
Visibility 1-31

## **W**

Weight of Workload Materials 7-4  
Wheel Nut Torque 4-87  
Window Washer Liquid 4-31  
Work Area 1-29  
Work Light Indicator Light 2-21  
Working Capacities 7-4  
Working Range and Dimensions 7-2